



SPLIT TYPE ROOM AIR
CONDITIONER
WALL MOUNTED TYPE

SERVICE MANUAL

Indoor unit	Outdoor unit
HSW-14FB	HOW-14FB
HSW-14UB	HOW-14UB



CONTENTS

SPECIFICATIONS	1
OUTLINE AND DIMENSIONS	2
REFRIGERANT SYSTEM DIAGRAM	3
CIRCUIT DIAGRAM	4
PCB CIRCUIT DIAGRAM	6
ERROR DISPLAY	8
DISASSEMBLY ILLUSTRATION	9
PARTS LIST	13
ACCESSORIES	16

SPECIFICATIONS

TYPE		COOLING	COOLING & HEATING
INDOOR UNIT		HSW-14FB	HSW-14UB
OUTDOOR UNIT		HOW-14FB	HOW-14UB
COOLING CAPACITY	(kW)	4.20	4.25
HEATING CAPACITY	(kW)	-----	4.80

ELECTRICAL DATA

POWER SOURCE		230V 50Hz	230V 50Hz	
RUNNING CURRENT	(A)	COOL	6.6	6.1
		HEAT	-----	5.6
INPUT WATTS	(kW)	COOL	1.48	1.38
		HEAT	-----	1.27
E.E.R	(kW/kW)	COOL	2.84	3.08
		HEAT	-----	3.78
MOISTURE REMOVAL	(ℓ /hr)	2.0	2.0	
AIR CIRCULATION-HI	(m³/hr)	700	COOL 700 HEAT 675	

COMPRESSOR

TYPE		Hermetic type, Permanent split condenser, 2 pole, Single phase, Induction motor	
DISCRIMINATION		802-360-45B	
POWER SOURCE		230V / 50Hz	
REFRIGERANT	R410A (g)	1040	1100

FAN MOTOR

POWER SUPPLY	(V)	230	230	
INDOOR UNIT	(r.p.m)	Hi-SPEED	1450	COOL 1450 HEAT 1400
		MED-SPEED	1320	COOL 1320 HEAT 1230
		LO-SPEED	1190	COOL 1190 HEAT 1060
		Quiet	1050	COOL 1050 HEAT 900
OUTDOOR UNIT	(r.p.m)	800	800	

DIMENSIONS

INDOOR UNIT	H x W x D (mm)	275 x 790 x 215
OUTDOOR UNIT	H x W x D (mm)	535 x 780 x 250

WEIGHT

INDOOR UNIT	GROSS / NET (kg)	12 / 9
OUTDOOR UNIT	GROSS / NET (kg)	37 / 35 39 / 37

NOISE LEVEL

INDOOR UNIT	(dB)	Hi-SPEED	43	COOL 43 HEAT 41
		MED-SPEED	40	COOL 40 HEAT 37
		LO-SPEED	37	COOL 37 HEAT 32
		S-LO	34	COOL 33 HEAT 27
OUTDOOR UNIT	(dB)	47	COOL 47 HEAT 48	

REFRIGERANT CHARGE (R410A)

FULL CHARGE AMOUNT	PIPE LENGTH	7.5 m	1,040 g	1,100 g
		10 m	1,090 g	1,150 g
		15 m	1,190 g	1,250 g
ADDITIONAL REFRIGERANT			20 g / m	

DIMENSIONS

Unit : mm

INDOOR UNIT

Models : HSW-14FB, HSW-14UB

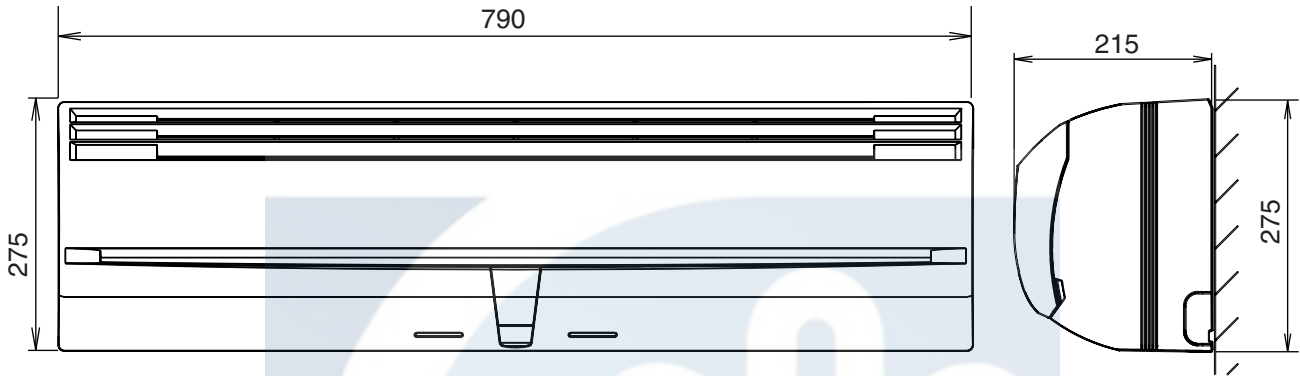

OUTDOOR UNIT

Models : HOW-14FB, HOW-14UB

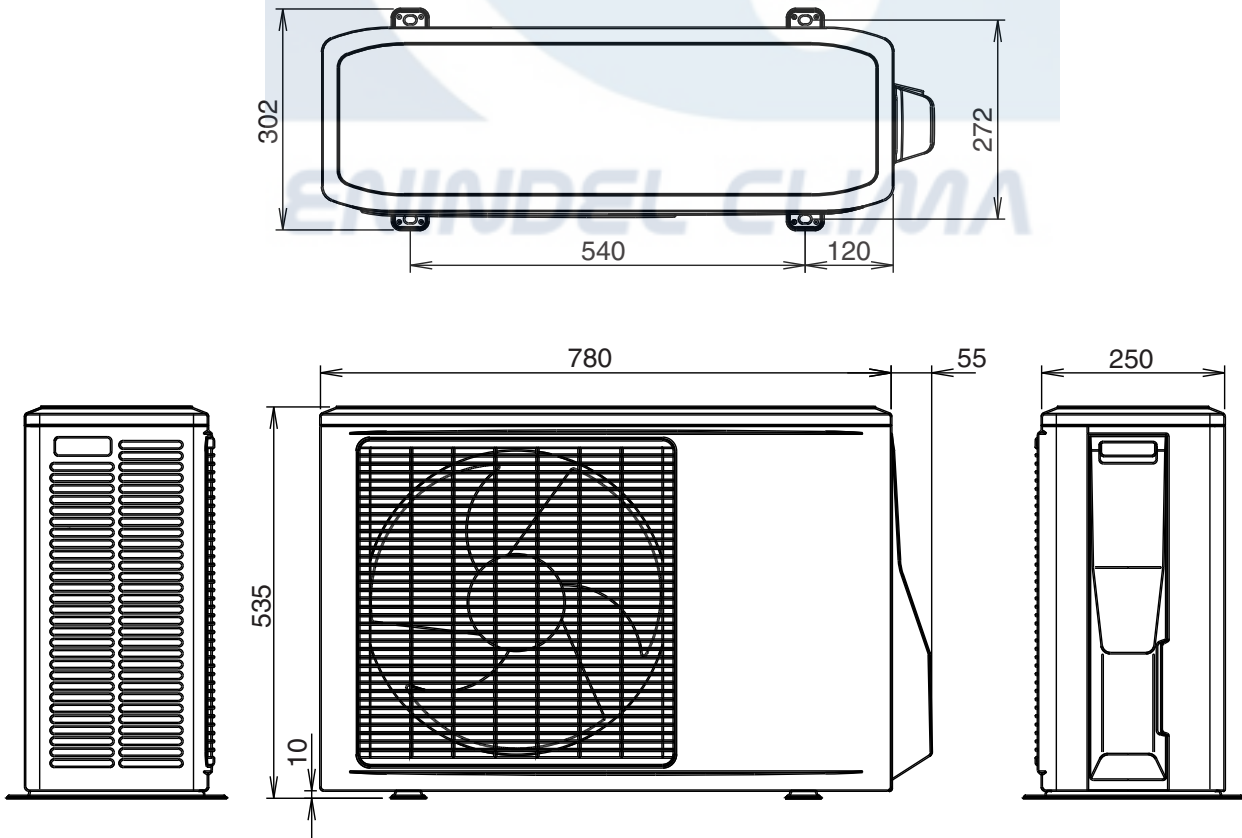

REFRIGERANT SYSTEM DIAGRAM

Models : HSW-14FB / HOW-14FB

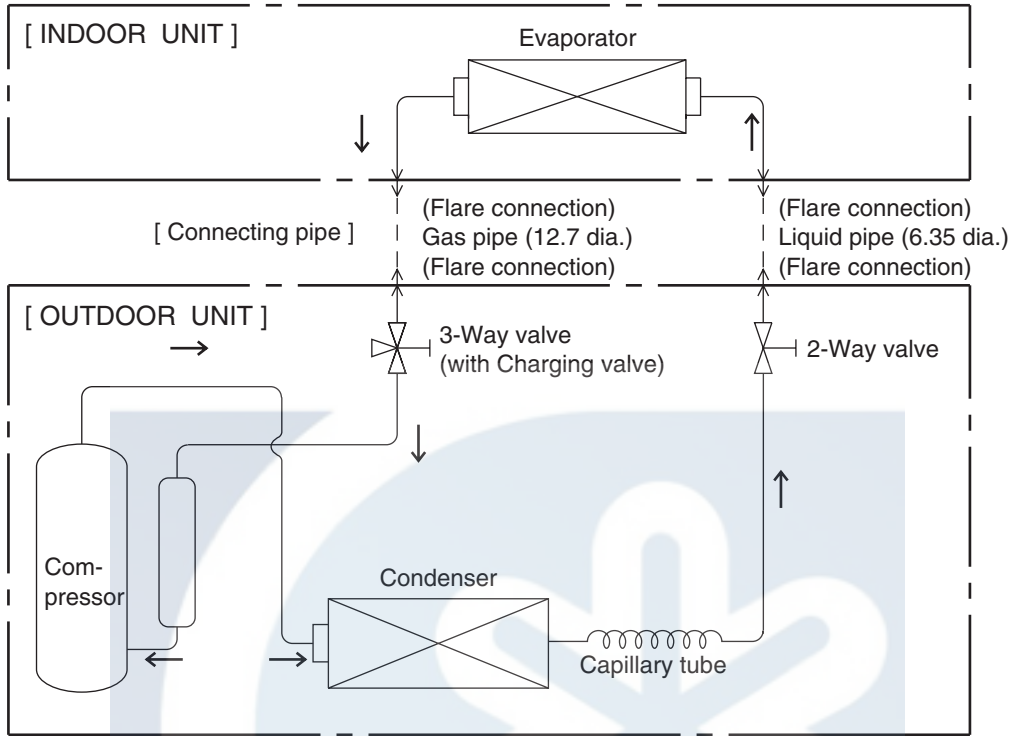

Models : HSW-14UB / HOW-14UB

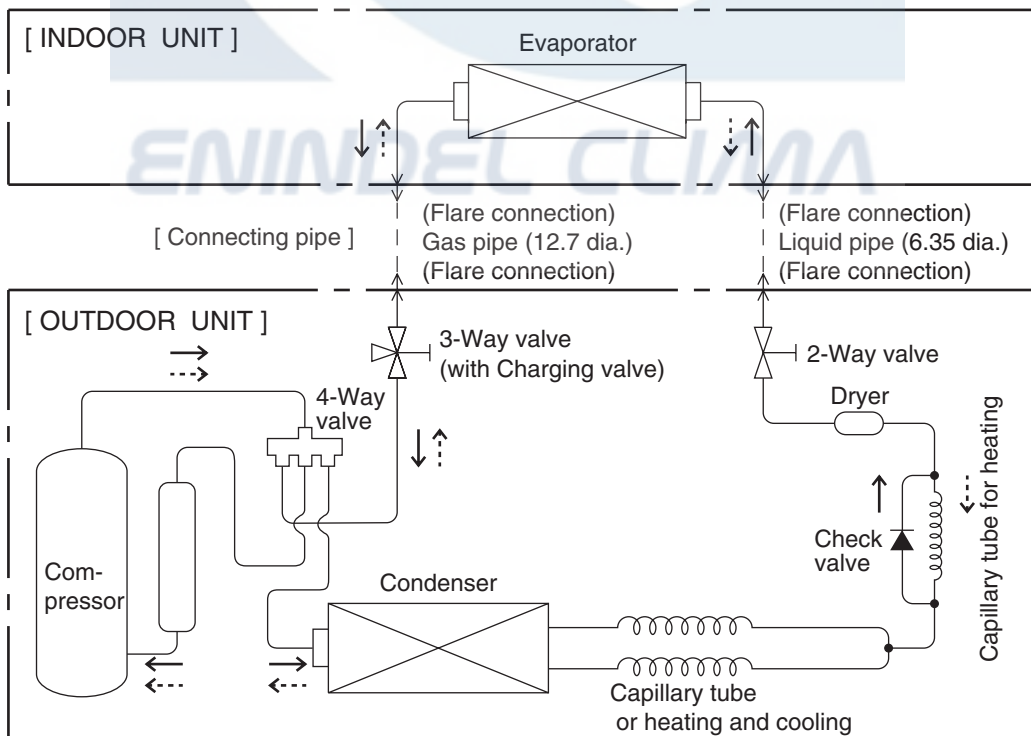

Cooling →
Heating ->->

CIRCUIT DIAGRAM

Model : HSW-14FB

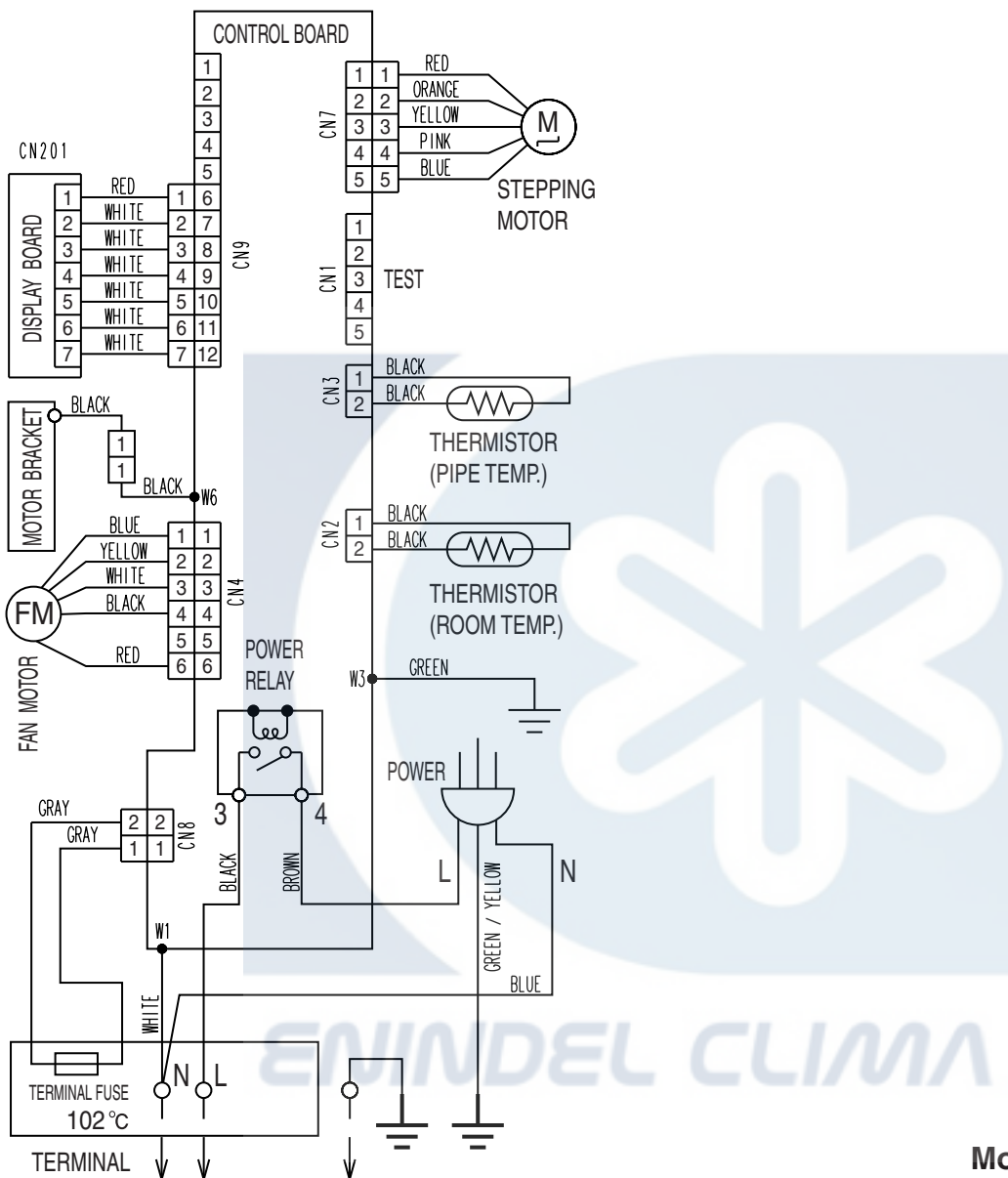

Model : HOW-14FB

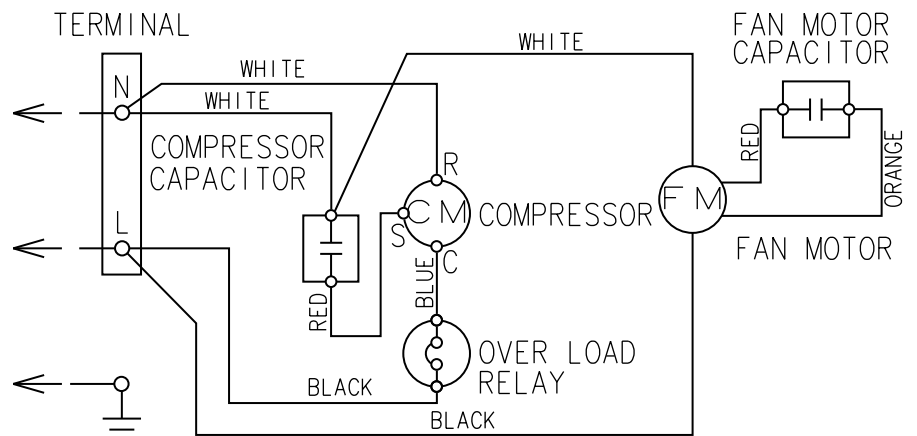

Model : HSW-14UB

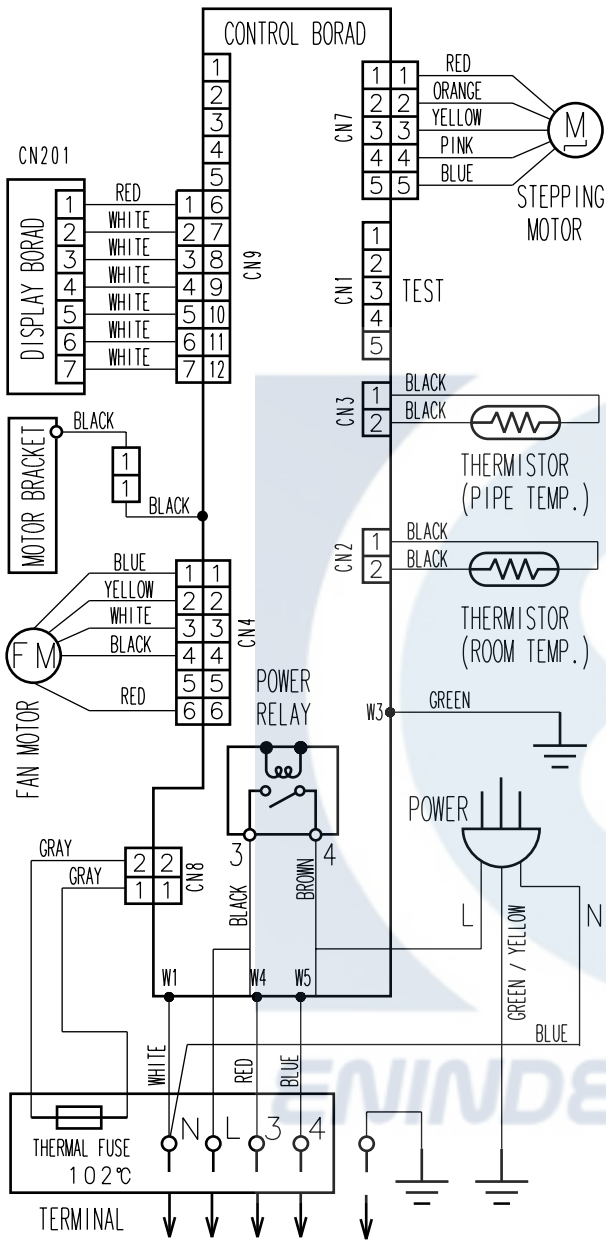

Model : HOW-14UB

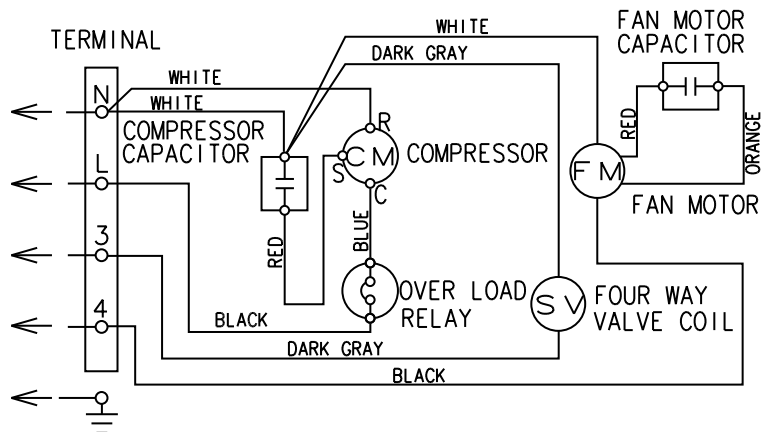

INDOOR PCB CIRCUIT DIAGRAM

Model : HSW-14FB

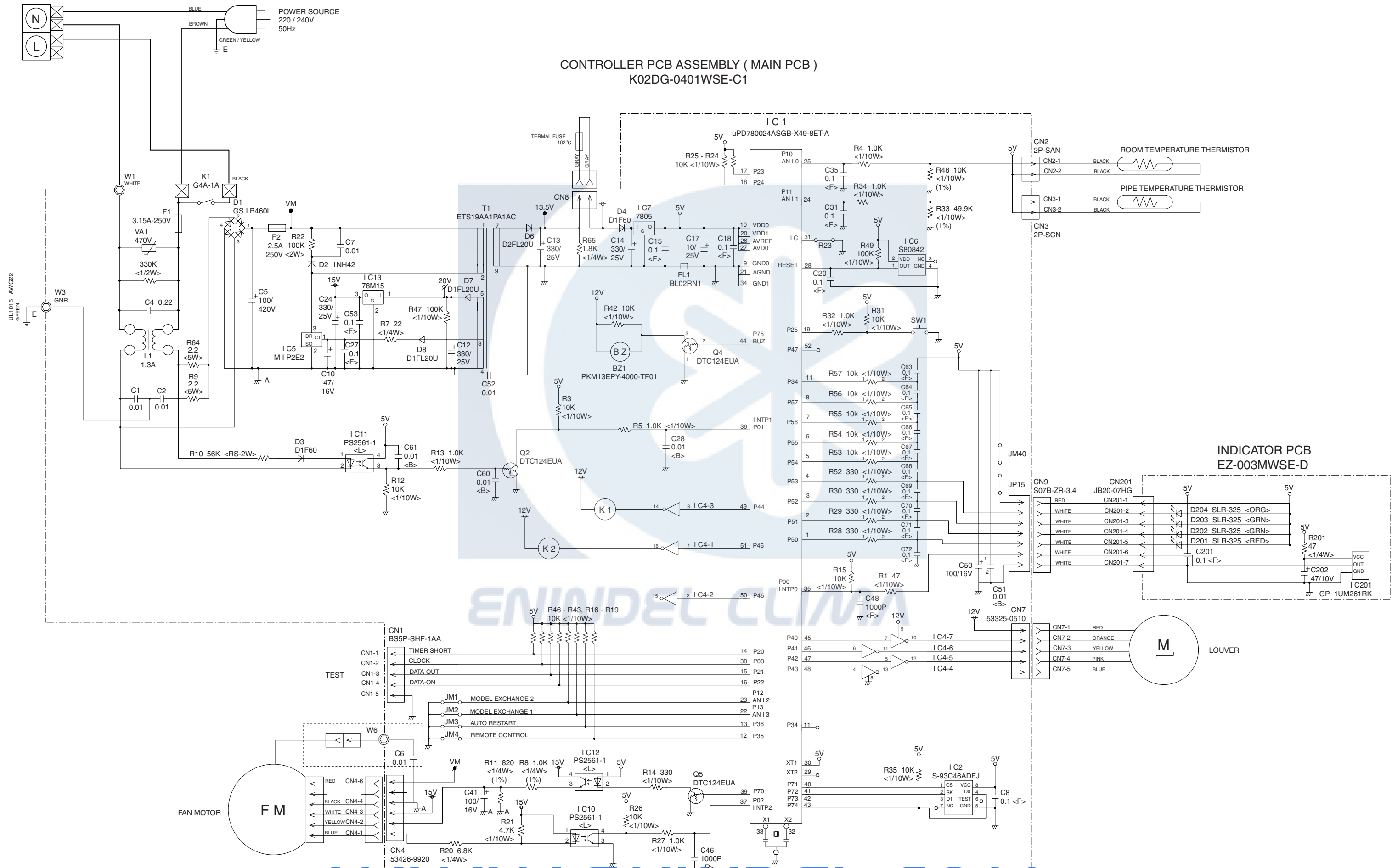

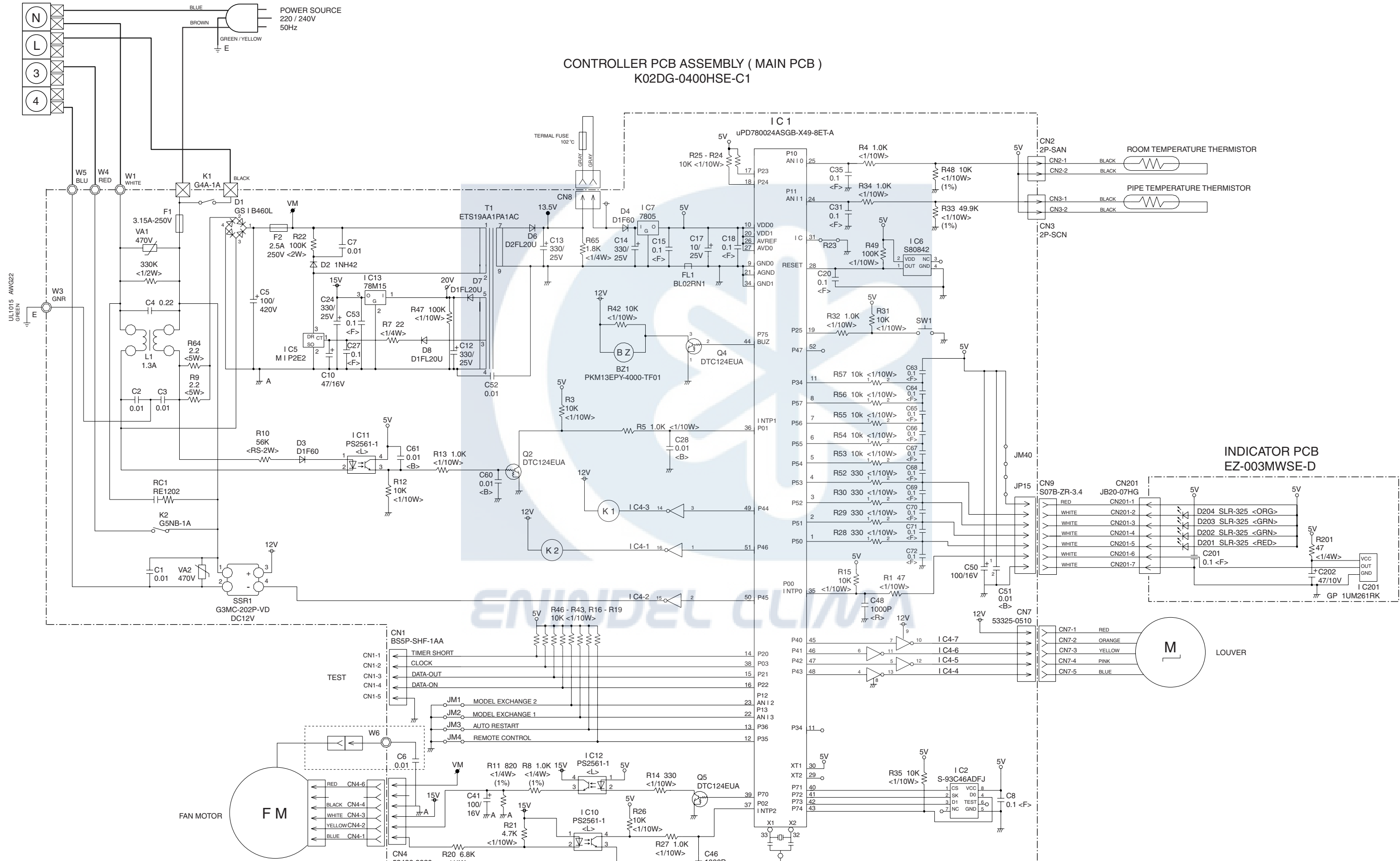

ERROR DISPLAY

Troubleshooting check table

Operation lamp : Red lamp
 Timer lamp : Green lamp

Large division indication			Small division indication		
Error contents	LED indication		Error contents	LED indication	
thermistor error	RED lamp Green lamp	● (2 times) ○	thermistor error (room temp.)	RED lamp Green lamp	○ ● (2 times)
			thermistor error (heat exchanger)	RED lamp Green lamp	○ ● (3 times)
control unit error (indoor unit)	RED lamp Green lamp	● (4 times) ○	MANUAL AUTO button error	RED lamp Green lamp	○ ● (2 times)
			power source Hz decision error	RED lamp Green lamp	○ ● (4 times)
fan motor error (indoor unit)	RED lamp Green lamp	● (6 times) ○	lock error	RED lamp Green lamp	○ ● (2 times)
			rpm error	RED lamp Green lamp	○ ● (3 times)

● : 0.5s ON/OFF repeated
 ○ : 0.1s ON/OFF repeated

ENINDEL CLIMA

DISASSEMBLY ILLUSTRATION

Indoor unit

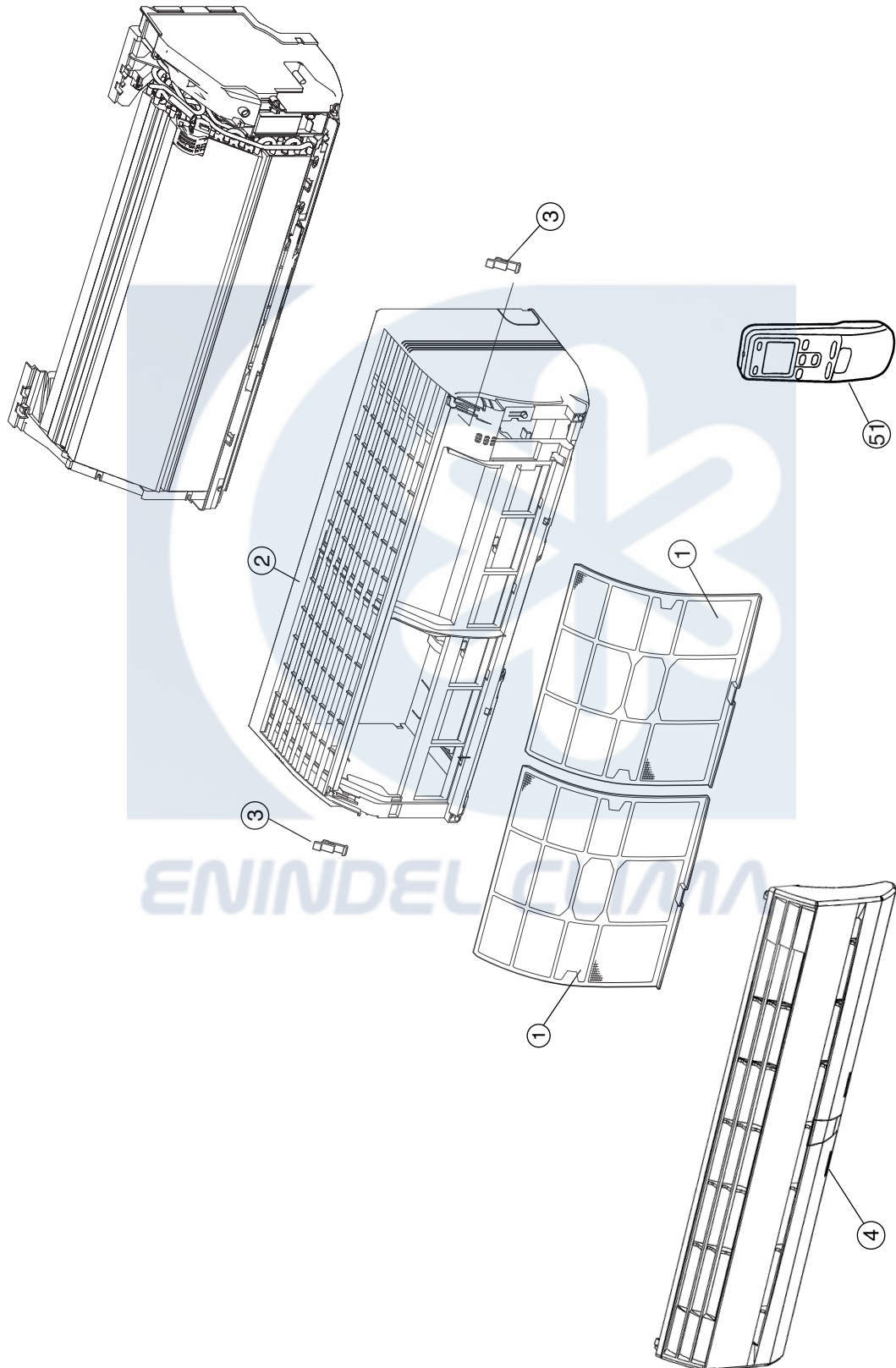

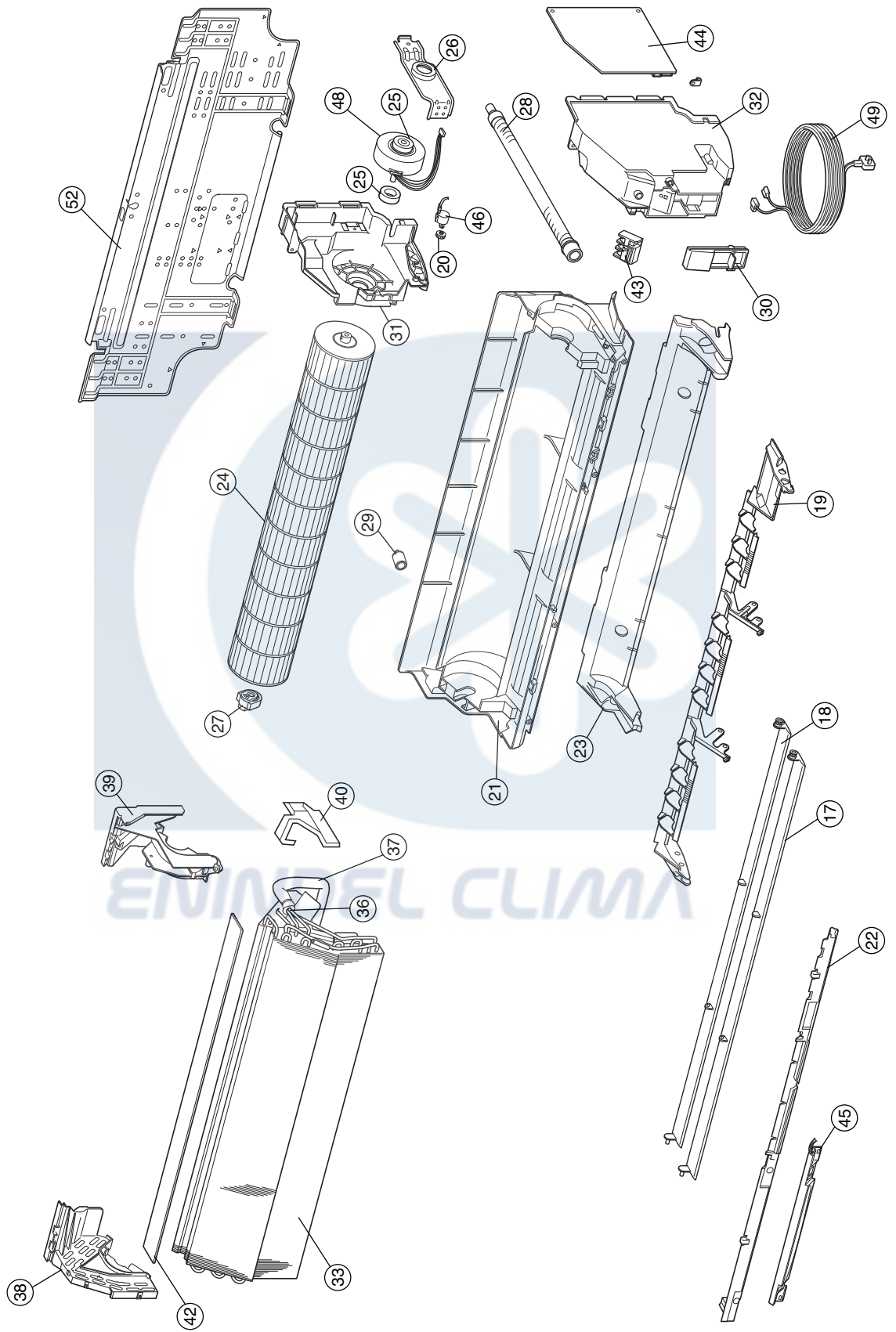

ENINDEL CLIMA

Model : HOW-14FB

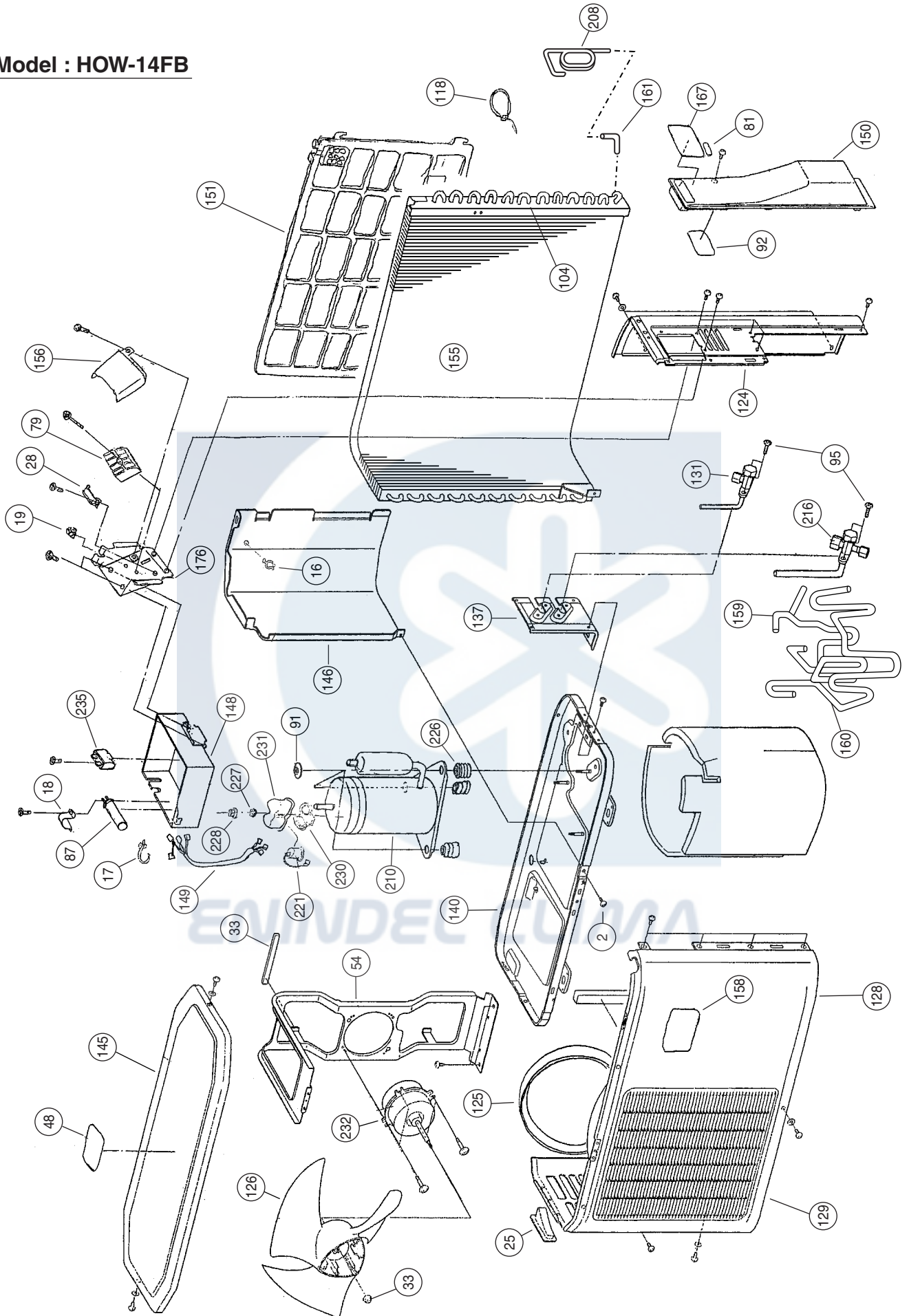

Model : HOW-14UB

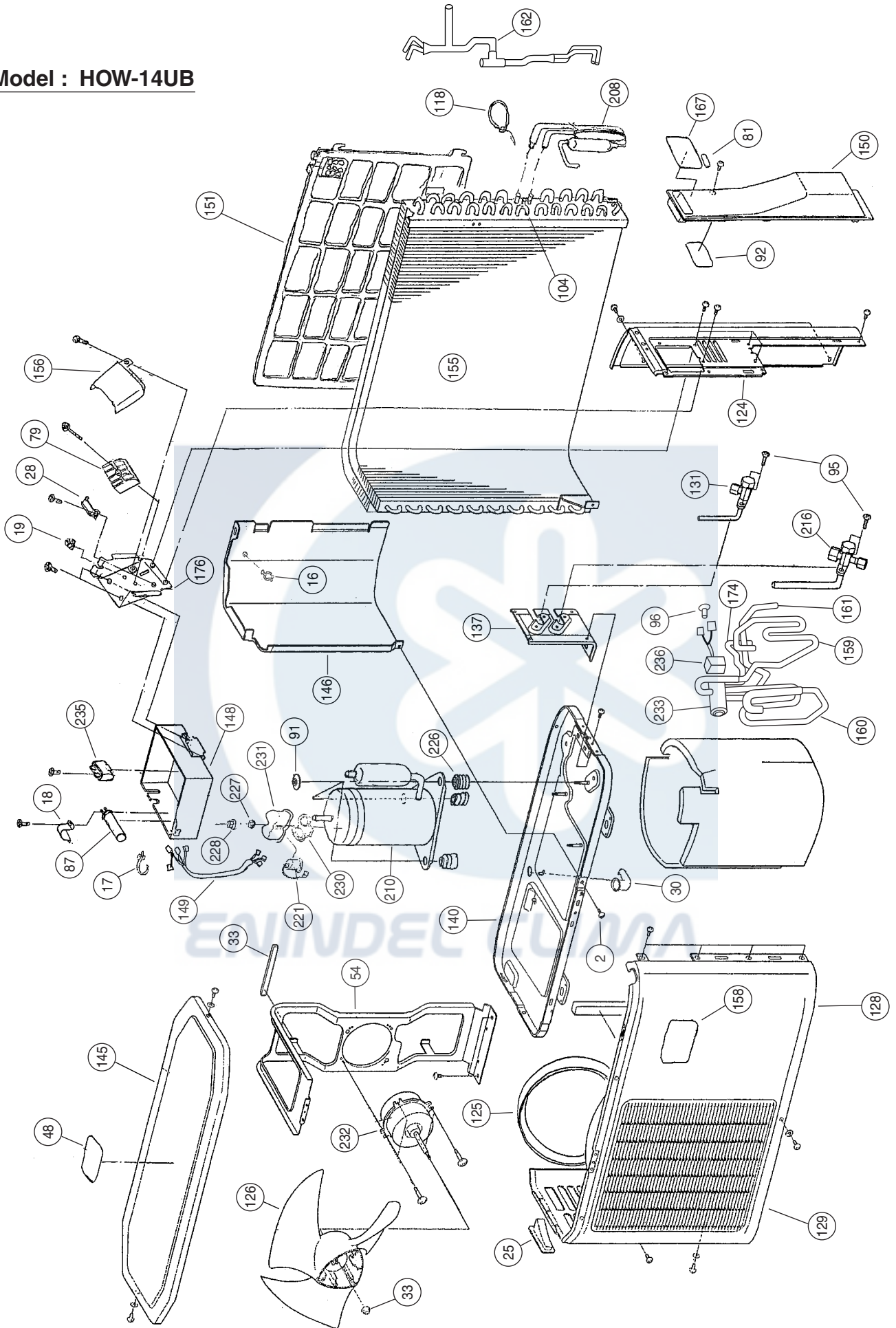

PARTS LIST

INDOOR UNIT

Ref.	Description	Part number	
		HSW-14FB	HSW-14UB
1	Air Filter	9309997011	9309997011
2	Front Panel	9309999039	9309999039
3	Clamper (Grille)	9306755010	9306755010
4	Intake Grill B Assy	9312142064	9312142064
17	Louver U Assy	9312368013	9312368013
18	Louver Z Assy	9312369010	9312369010
19	Holder (Louver) Assy	9312361014	9312361014
20	Gear A	9309994003	9309994003
21	Casing Assy	9312112074	9312112074
23	Cover (Casing) B	9309988002	9309988002
24	Crossflow Fan Assy	9307836015	9307836015
25	Motor Cushion B	9306274009	9306274009
26	Clamper (Motor)	9310102008	9310102008
27	Shaft Holder-C Assy	9306628017	9306628017
28	Drain hose Assy	9310357019	9310357019
29	Drain Cap Assy	9304150008	9304150008
30	Wire Clamper	9311946014	9311946014
31	Box (Switch)	9309996014	9309996014
32	Cover (Switch)	9311863014	9311863014
33	Evaporator Total Assy	9313099015	9313099015
36	Joint Pipe Assy	9311497011	9311497011
37	Insulation (Pipe) E	9304607007	9304607007
38	Holder (Evaporator) L	9309982017	9309982017
39	Holder (Evaporator) R	9309983014	9309983014
40	Water Seal	9312912018	9312912018
42	Air Seal	9310611005	9310611005
43	Terminal	9701955022	9701955039
44	Controller PCB Assy	9705611023	9705611016
		(K02DG-0401WSE-C1)	(K02DG-0400HSE-C1)
46	Step Motor	9900139025	9900139025
48	Fan Motor Assy	9601351016	9601351016
51	Remote Control	9313693022	9371190174
52	Bracket Panel	9310001004	9310001004
38	Flow Control Panel U	9309991026	9309991026
39	Flow Control Panel Z	9309992023	9309992023
40	Power Cord Assy	9900157012	9900157012
42	Display PCB Assy	9705039025	9705039025
43	Pipe Thermister	9702039073	9702039073
44	Room Thermister	9700801108	9700801108

OUTDOOR UNIT

Ref. No.	Description	Part No.	Ord. Q'ty	Ref. No.	Description	Part No.	Ord. Q'ty
		HOW-14FB				HOW-14FB	
2	Screw, Taptite (Earth)	0700179013		146	Separator	9310969014	
3	Screw	301171134250		148	Box (Switch)	9310971024	
16	Clamp No.1219	313361271706		149	Sealed Tube	9305695027	
17	Clamp SKB-100	313361275805		150	Cover (Switch)	9310979013	
18	Capacitor Clamp	313468061808		151	Protection Net	9310980019	
19	Screw with Washer	313681304205		155	Condenser	9313725013	
20	Air Pipe	9300895002		156	Cover (Terminal)	9311021018	
25	Grip	9302061016		158	Emblem-Rear	9313739003	
28	Cord Clamp	9302271002		169	Top Seal-B	9311088004	
33	Heat Insulation (Motor)	9304859000		170	Cabinet Seal-B	9311096009	
35	Special Nut with Washer	9304902003		171	Cabinet Seal-A	9311097006	
48	Label (Warning)	9305870028		172	Top Seal-A	9311099000	
54	Bracket (Motor)	9306047023		174	Entrance Pipe	9311105008	
79	Terminal	9306489014		176	Bracket (Terminal)	9311347026	
81	Label (origin)	9306536015		177	Noise Insulation-C	9311480013	
87	Running Capacitor	9307588068		186	Noise Insulation-F	9911642015	
91	Special Nut	9307615016		192	Dryer	9312056002	
95	Hex Bolt	9307835001		208	Capillary Assy	9313721015	
96	Screw	9308037008		210	Compressor Assy	9313741013	
104	U-Pipe Y	9308442000		211	OCR	9373129011	
118	Clamp	9309608016		216	3-Way Valve Assy	9313060015	
124	Panel Rear	9309870024		224	Washer	9351522018	
125	Fan Ring	9309876019		226	Rubber Sheat-A	9359425014	
126	Propeller Fan	9309909014		227	Terminal Washer	9359428015	
128	Cabinet, Painted	9309928053		228	Nut	9359430018	
129	Blow Grill	9309929012		230	Terminal Gasket	9362004008	
131	2-Way Valve	9310084014		231	Terminal Cover	9351120009	
137	BCT (Valve)	9310229026		232	Motor, Induct	9601541011	
140	Base, Painted	9310248065		235	Running Capacitor	9900089030	
145	Panel (Top), Painted	9310338063					

When you order parts, please make a photocopy of this page and fill the number of the parts in the "Order" column.

OUTDOOR UNIT

Ref. No.	Description	Part No.	Ord. Q'ty	Ref. No.	Description	Part No.	Ord. Q'ty
		HOW-14UB				HOW-14UB	
2	Screw, Taptite (Earth)	0700179013		146	Separator	9310969014	
3	Screw	301171134250		148	Box (Switch)	9310971024	
16	Clamp No.1219	313361271706		150	Cover (Switch)	9310979013	
17	Clamp SKB-100	313361275805		151	Protection Net	9310980019	
18	Capacitor Clamp	313468061808		155	Condenser	9312587018	
19	Screw with Washer	313681304205		156	Cover (Terminal)	9311021018	
25	Grip	9302061016		158	Emblem-Rear	9313739003	
28	Cord Clamp	9302271002		169	Top Seal-B	9311088004	
30	Drain Pipe Assy	9303029015		170	Cabinet Seal-B	9311096009	
33	Heat Insulation (Motor)	9304859000		171	Cabinet Seal-A	9311097006	
35	Special Nut with Washer	9304902003		172	Top Seal-A	9311099000	
48	Label (Warning)	9305870028		176	Bracket (Terminal)	9311347026	
54	Bracket (Motor)	9306047030		177	Noise Insulation-C	9311480013	
79	Terminal	9306488017		186	Noise Insulation-F	9911642015	
81	Label (origin)	9306536015		208	Capillary Assy	9313715014	
87	Running Capacitor	9307588068		210	Compressor Assy	9313741013	
91	Special Nut	9307615016		211	OCR	9373129011	
95	Hex Bolt	9307835001		216	3-Way Valve Assy	9313060015	
96	Screw	9308037008		224	Washer	9351522018	
104	U-Pipe Y	9308442000		226	Rubber Sheat-A	9359425014	
118	Clamp	9309608016		227	Terminal Washer	9359428015	
124	Panel Rear	9309870024		228	Nut	9359430018	
125	Fan Ring	9309876019		230	Terminal Gasket	9362004008	
126	Propeller Fan	9309909014		231	Terminal Cover	9351120009	
128	Cabinet, Painted	9309928053		232	Motor, Induct	9601541011	
129	Blow Grill	9309929012		233	4-Way Valve	9900162016	
131	2-Way Valve	9313056018		235	Running Capacitor	9900089030	
137	BCT (Valve)	9310229026		236	Solenoid	9970003011	
140	Base, Painted	9310248065					
145	Panel (Top), Painted	9310338063					

When you order parts, please make a photocopy of this page and fill the number of the parts in the "Order" column.

STANDARD ACCESSORIES

Name and Shape	Part No.
Wall hook bracket 	9310001004
Remote control unit 	9313693022 for FB
	9371190174 for UB
Battery (penlight) 	0600185534
Cloth tape 	9310519004
Tapping screw (big) 	0700076046
Tapping screw (small) 	0700019036
Seal A 	9304536000
Remote control unit holder 	9305642014
Drain Pipe 	9303029015

