



**SPLIT TYPE
ROOM AIR CONDITIONER
WALL MOUNTED type**

SERVICE MANUAL



ENINDEL CLIMA

Models

Indoor unit	Outdoor unit
HSW-9UC	HOW-9UC
HSW-9UC	HOW-9UD
HSW-12UC	HOW-12UC

CONTENTS

SPECIFICATIONS	1
OUTLINE AND DIMENSIONS	2
REFRIGERANT SYSTEM DIAGRAM ..	4
CIRCUIT DIAGRAM	5
INDOOR PCB CIRCUIT DIAGRAM	7
DISASSEMBLY ILLUSTRATION	9
PARTS LIST	14

SPECIFICATIONS

TYPE		COOLING & HEATING		
INDOOR UNIT		HSW-9UC		HSW-12UC
OUTDOOR UNIT		HOW-9UC	HOW-9UD	HOW-12UC
COOLING CAPACITY	(kW)	2.60	2.60	3.25
HEATING CAPACITY	(kW)	2.95	2.95	3.95

ELECTRICAL DATA

POWER SOURCE		230V 50Hz	230V 50Hz	230V 50Hz
RUNNING CURRENT	(A)			
	COOL	4.8	4.8	5.9
	HEAT	4.1	4.1	5.6
INPUT WATTS	(kW)			
	COOL	1.07	1.07	1.35
	HEAT	0.90	0.90	1.28
E.E.R.	(kW/kW)			
	COOL	2.43	2.43	2.41
	HEAT	3.28	3.28	3.09
MOISTURE REMOVAL	(ℓ/h)	1.3	1.3	1.8
AIR CIRCULATION-Hi	(m ³ /hr)	COOL 540 HEAT 515	COOL 540 HEAT 515	COOL 535 HEAT 545

COMPRESSOR

TYPE		Hermetic type, Permant split condenser, 2 pole, Single phase, Induction motor, Rotary		
DISCRIMINATION		802-141-45B	PA118X1C-4DZ	802-361-35B
POWER SOURCE		220, 230, 240V / 50Hz	220, 230, 240V / 50Hz	220, 230, 240V / 50Hz
REFRIGERANT	R410A (g)	650	650	750
REFRIGERANT CHARGE	Pipe length	7.5 m	650	650
		10 m	700	700
	(g)	15 m	800	800
ADDITIONAL REFRIGERANT	(g / m)	20	20	20

FAN MOTOR

POWER SUPPLY		(V)	230	230	230
INDOOR UNIT	(r.p.m.)	HI-SPEED	COOL 1310 HEAT 1250	COOL 1310 HEAT 1250	COOL 1310 HEAT 1330
		MED-SPEED	COOL 1170 HEAT 1140	COOL 1170 HEAT 1140	COOL 1200 HEAT 1210
		LO-SPEED	COOL 1030 HEAT 1020	COOL 1030 HEAT 1020	COOL 1090 HEAT 1090
		QUIET	COOL 900 HEAT 900	COOL 900 HEAT 900	COOL 980 HEAT 980
OUTDOOR UNIT	(r.p.m.)		800	800	770

DIMENSIONS

INDOOR UNIT	H x W x D	(mm)	257 x 808 x 187	257 x 808 x 187	257 x 808 x 187
OUTDOOR UNIT	H x W x D	(mm)	535 x 650 x 250	535 x 650 x 250	535 x 695 x 250

WEIGHT

INDOOR UNIT	GROSS / NET	(kg)	10 / 8	10 / 8	10 / 8
OUTDOOR UNIT	GROSS / NET	(kg)	29 / 26	29 / 26	34 / 31

NOISE LEVEL

INDOOR UNIT	(dB)	HI-SPEED	COOL 40 HEAT 38	COOL 40 HEAT 38	COOL 40 HEAT 40
		MED-SPEED	COOL 38 HEAT 36	COOL 38 HEAT 36	COOL 38 HEAT 38
		LO-SPEED	COOL 35 HEAT 34	COOL 35 HEAT 34	COOL 36 HEAT 35
		SUPER QUIET	COOL 30 HEAT 28	COOL 30 HEAT 28	COOL 33 HEAT 32
OUTDOOR UNIT	(dB)		COOL 46 HEAT 46	COOL 46 HEAT 46	COOL 48 HEAT 48

DIMENSIONS

Unit : mm

INDOOR UNIT

Models : HSW-9UC
HSW-12UC

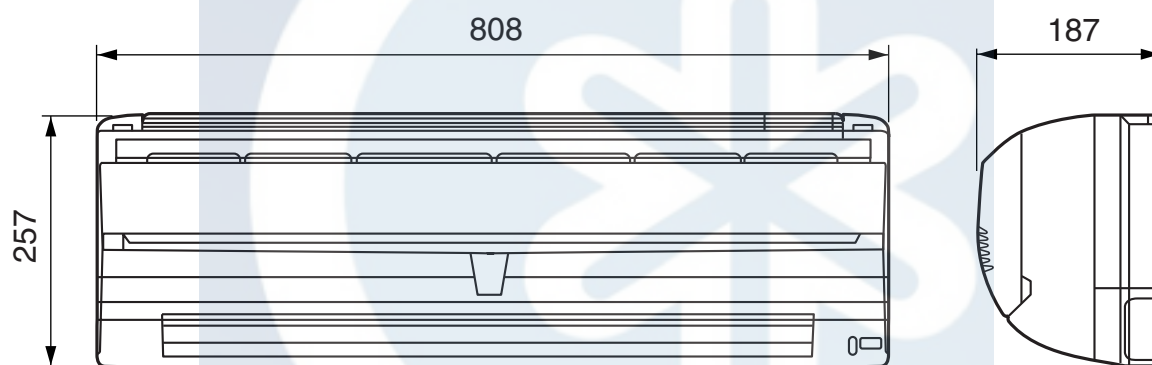

OUTDOOR UNIT

Model : HOW-9UC
HOW-9UD

Unit : mm

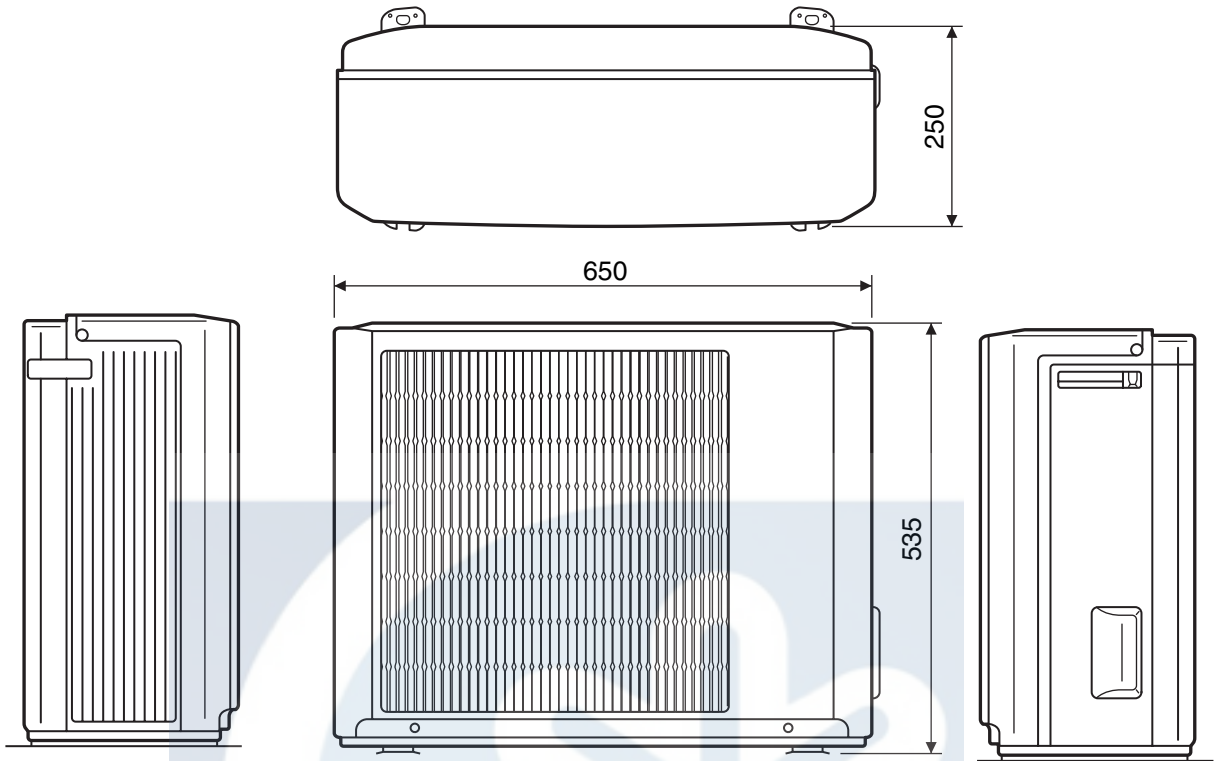

Model : HOW-12UC

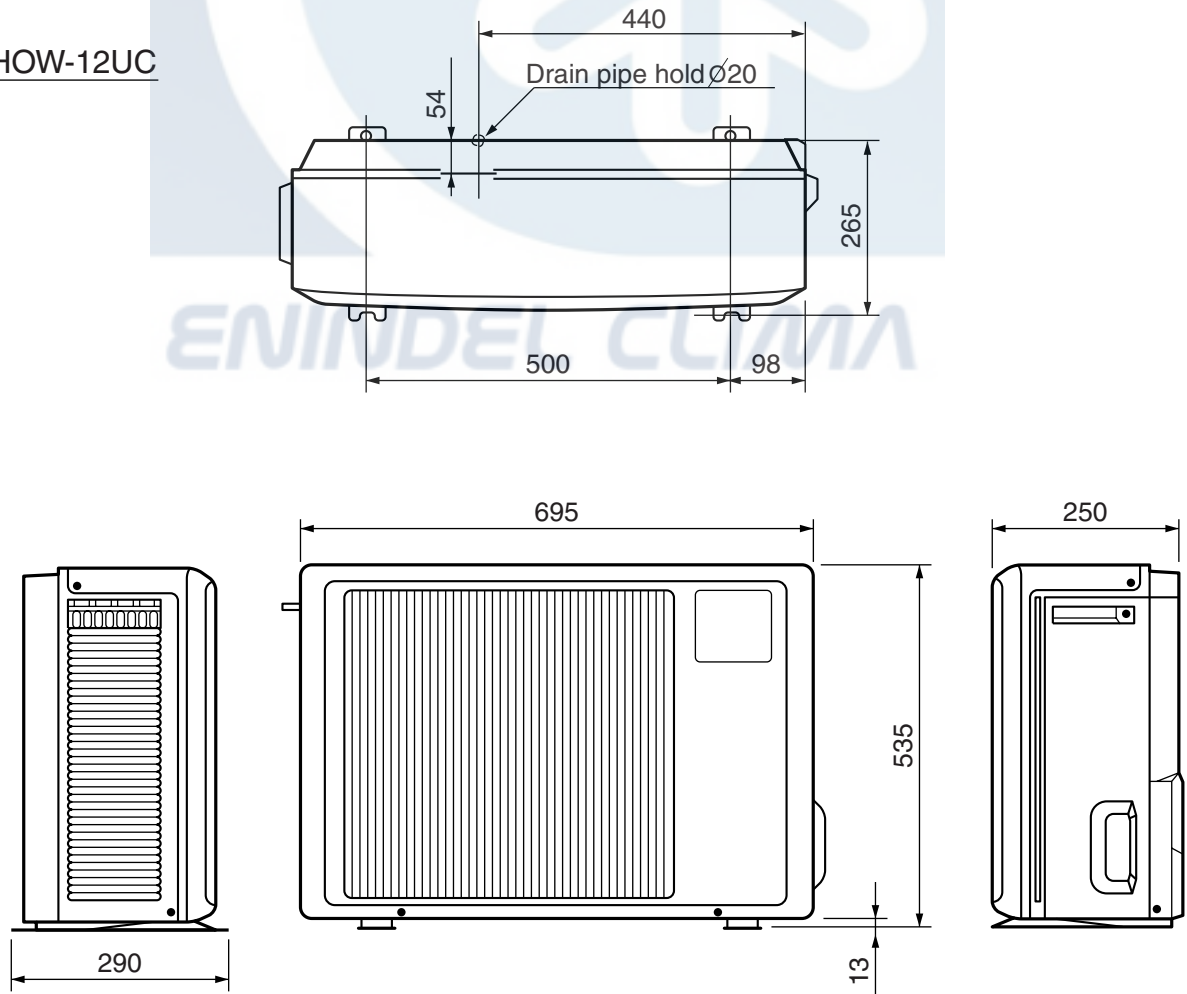



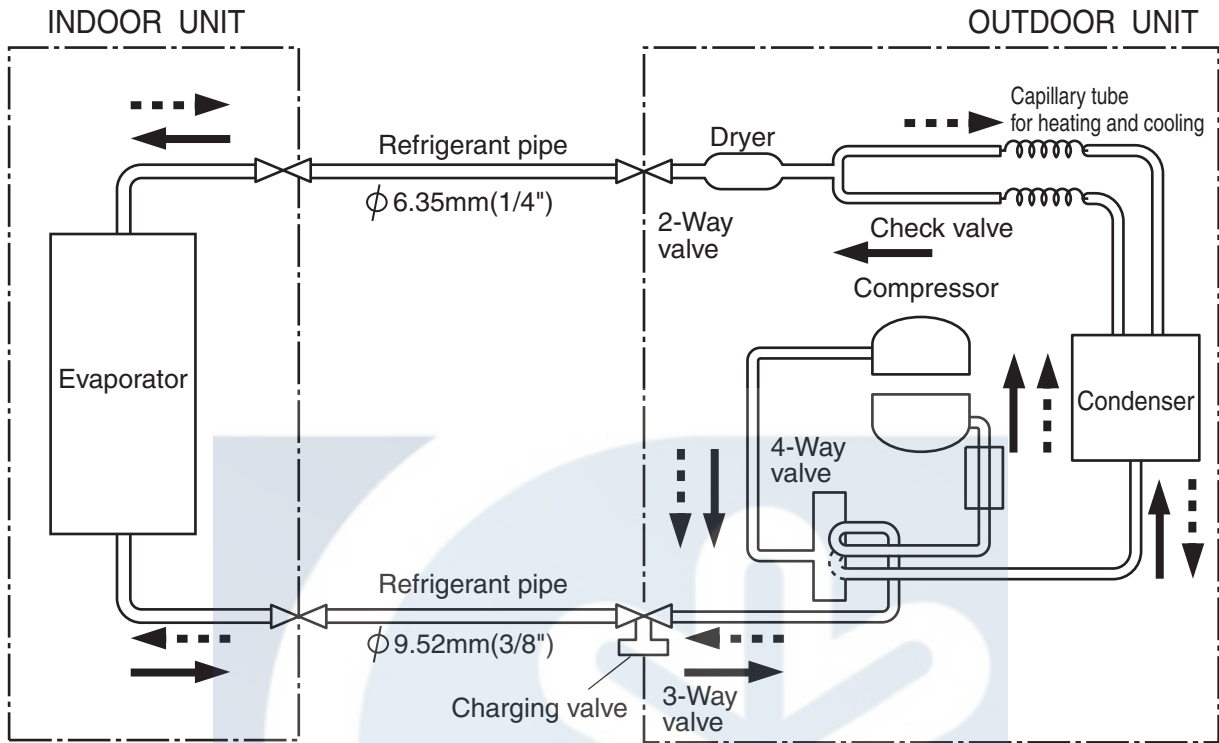

REFRIGERANT SYSTEM DIAGRAM

**Models : HSW-9UC / HOW-9UC
HSW-9UC / HOW-9UD**

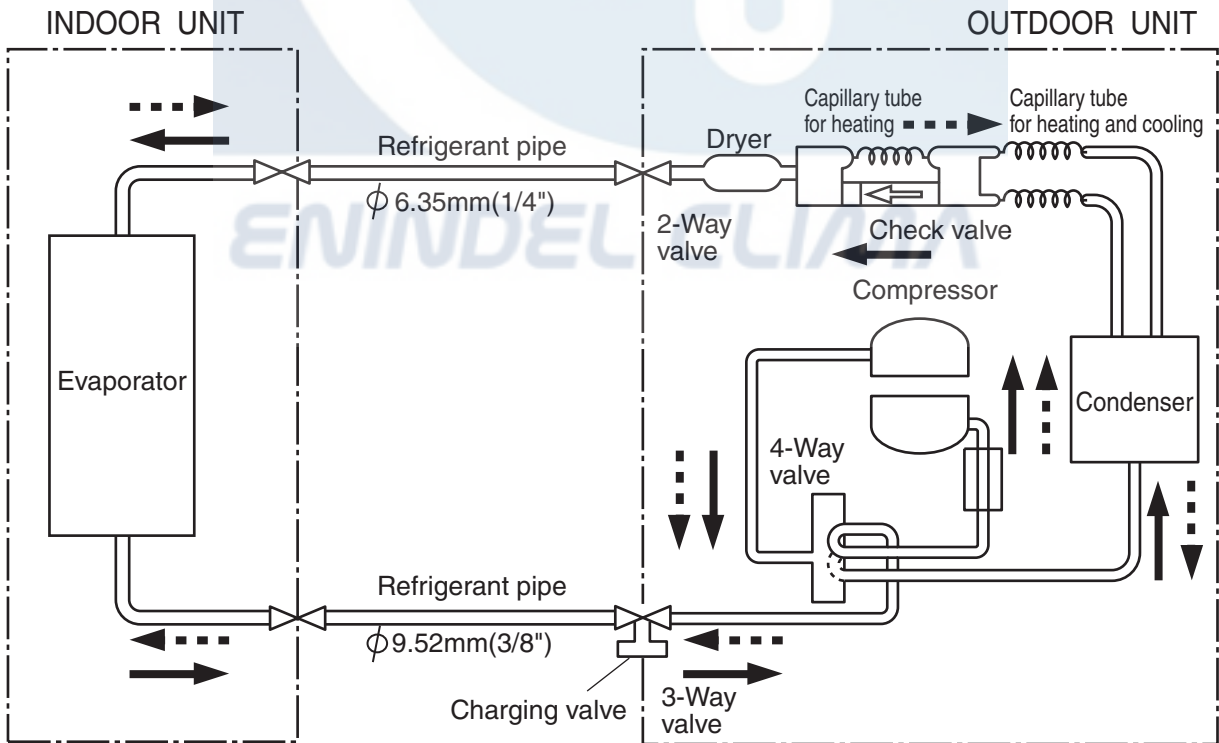

Models : HSW-12UC / HOW-12UC



-  Cooling
-  Heating
-  : Flare coupling

CIRCUIT DIAGRAM

Models : HSW-9UC
HSW-12UC

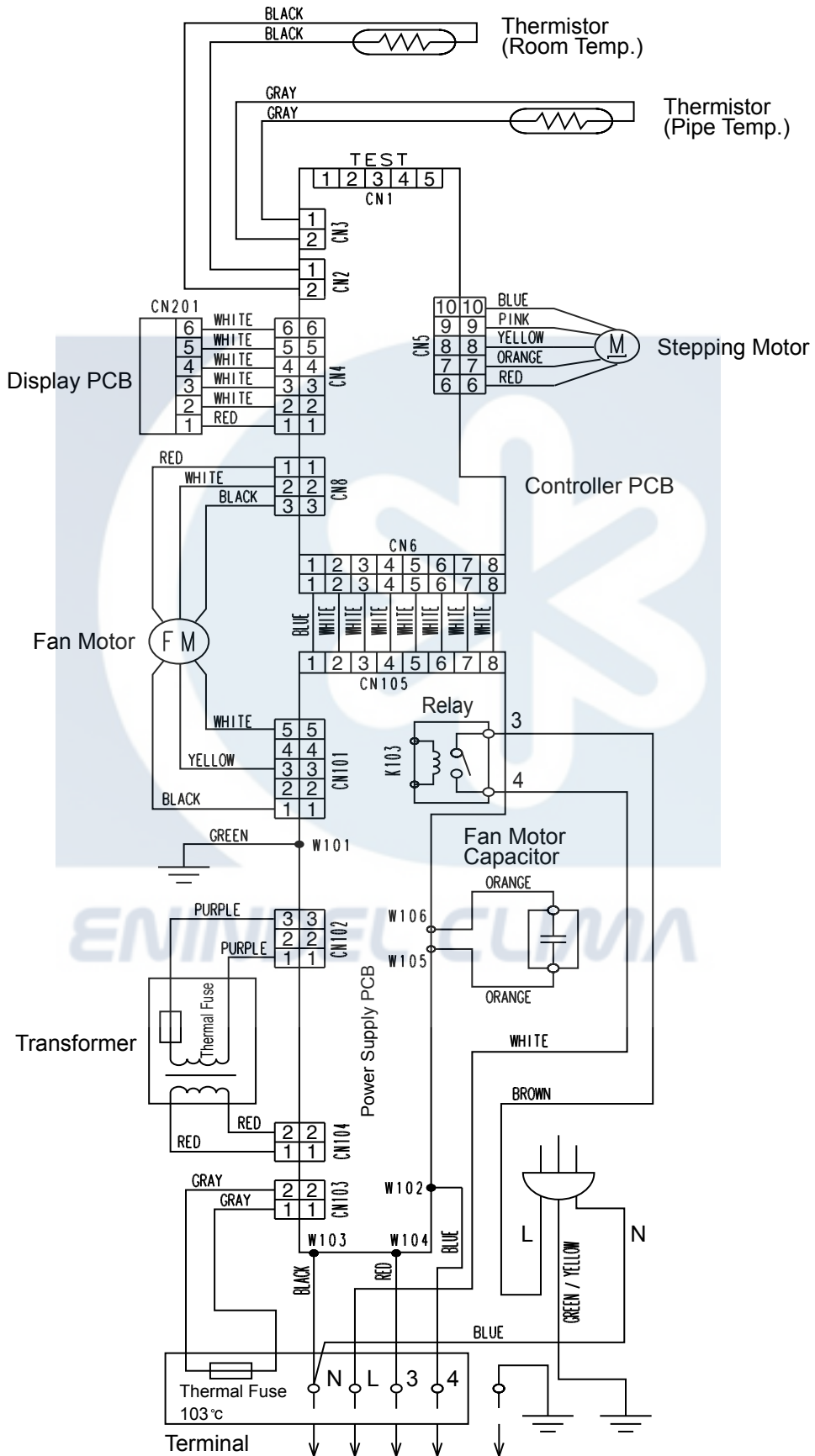

**Models : HOW-9UC
HOW-12UC**

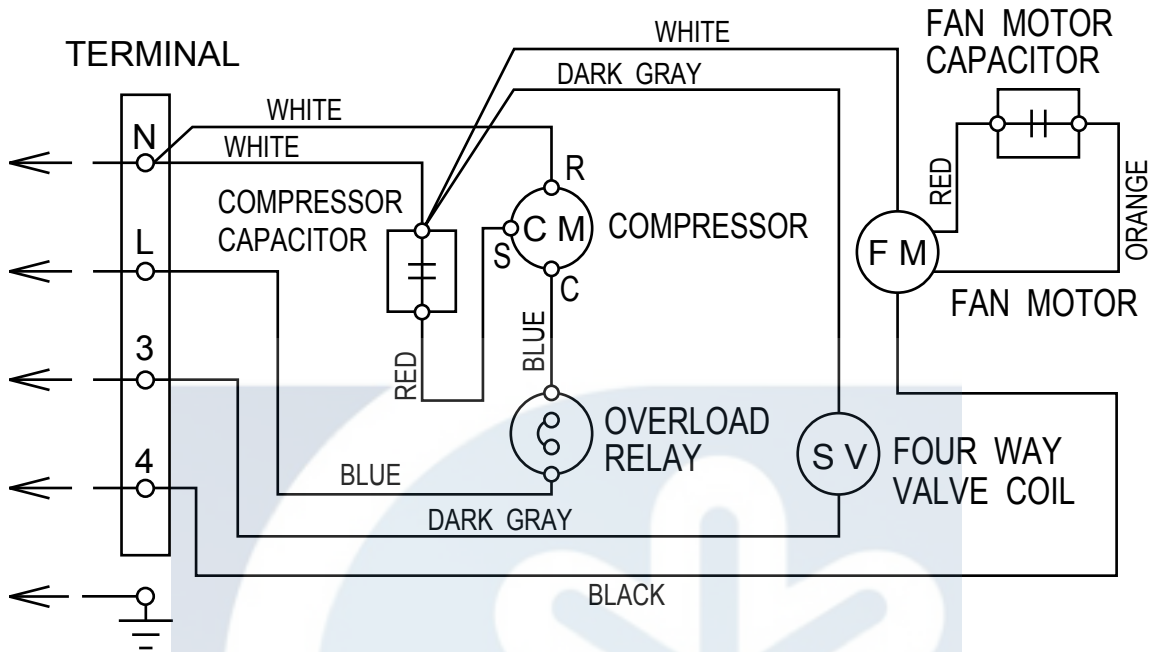

Model : HOW-9UD

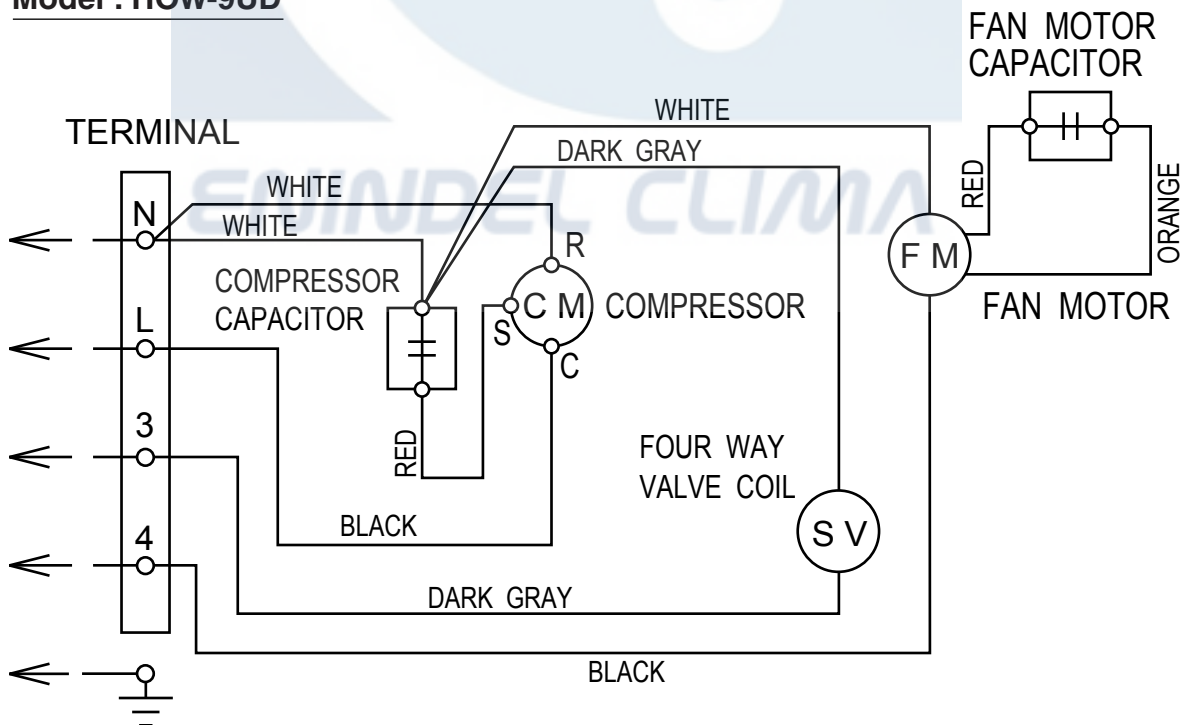

INDOOR PCB CIRCUIT DIAGRAM

Jumper wire configurations

Switch	Function	ON/Linked	OFF/Open
JP1	Heating compensation	+4	+2
JP2	Cooling compensation	0	-2
JP3	Auto restart	enable	disable
JP4	Custom code	A	B

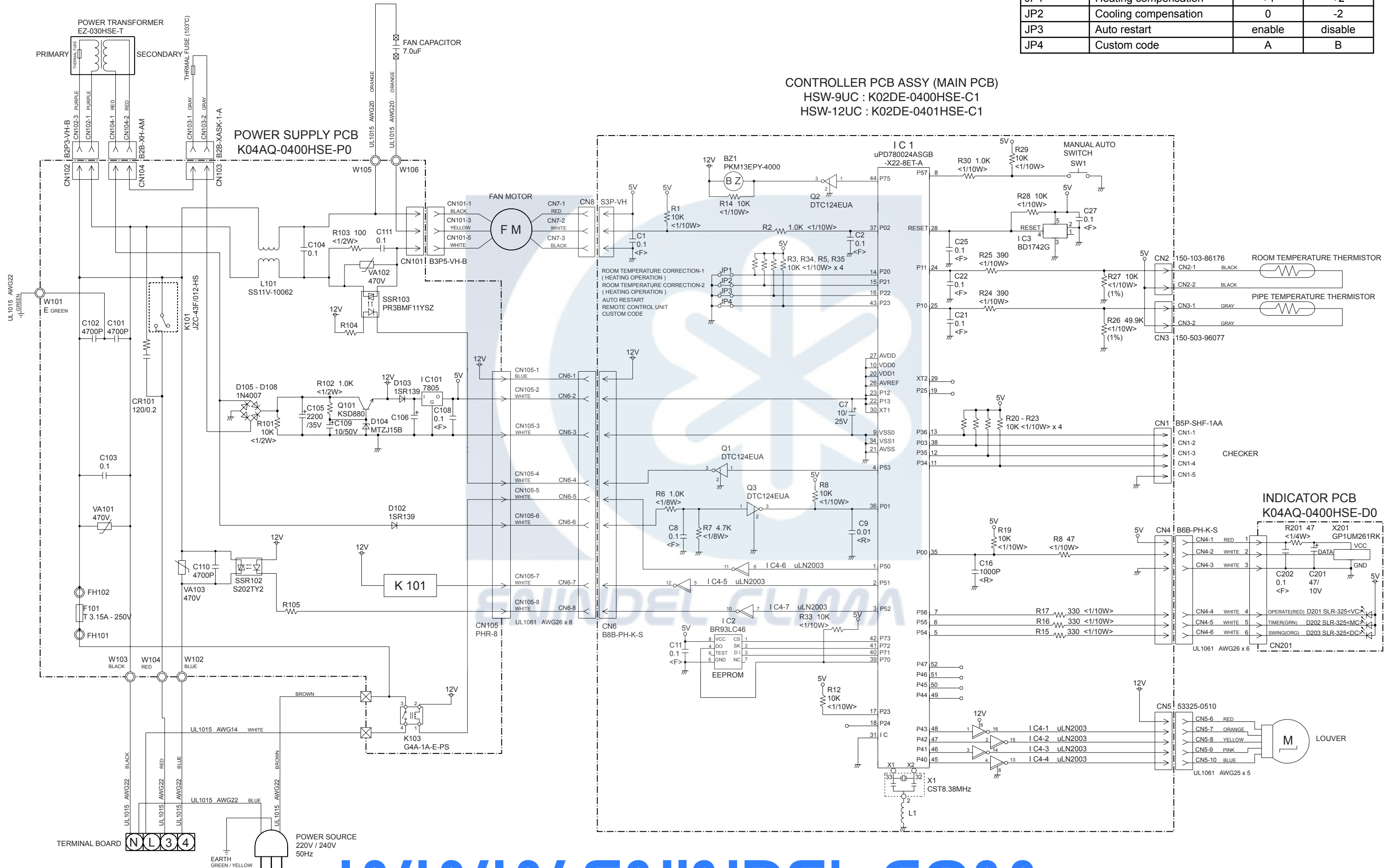

DISASSEMBLY ILLUSTRATION

Models : HSW-9UC
HSW-12UC

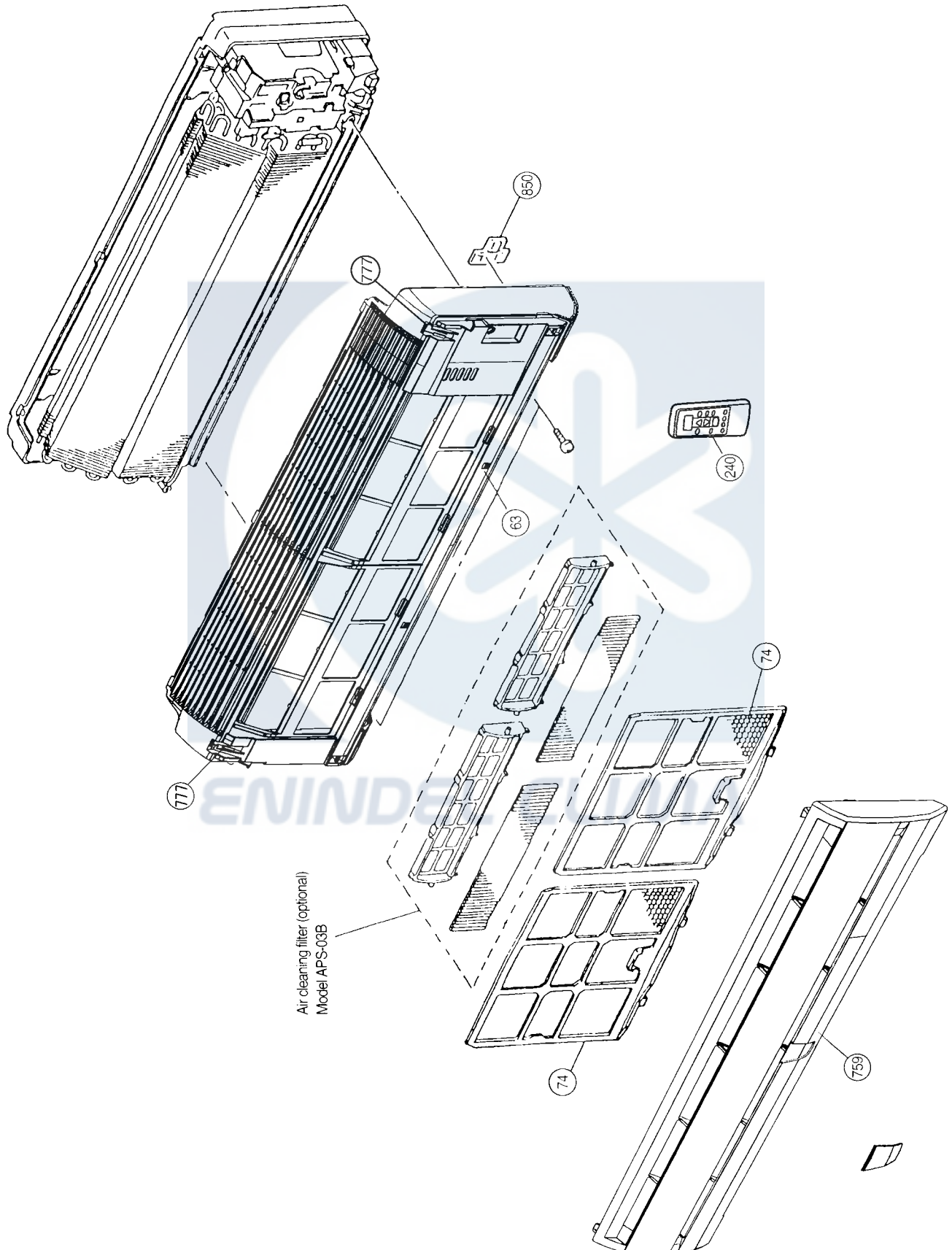

Models : HSW-9UC
HSW-12UC

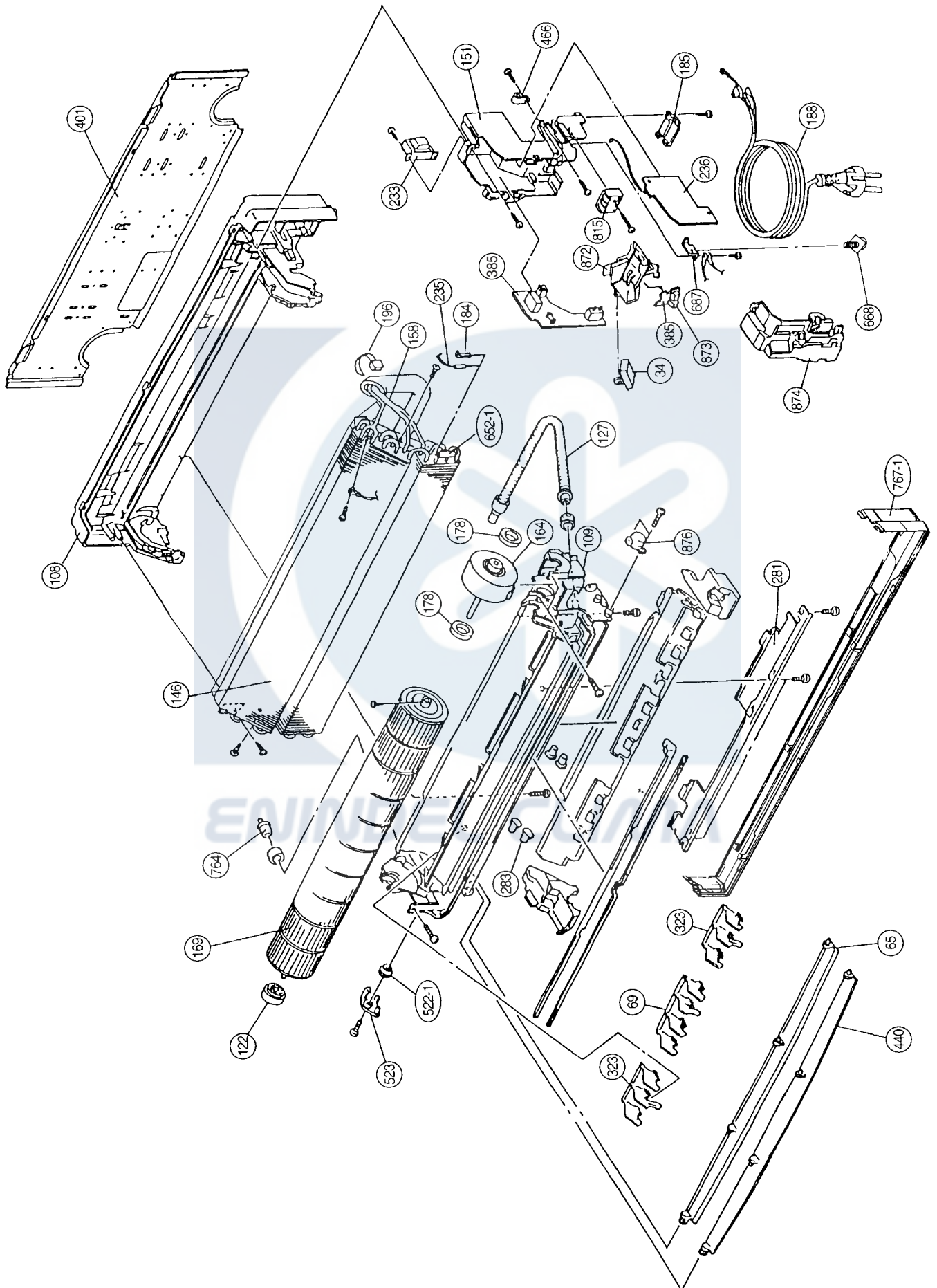

Model : HOW-9UC

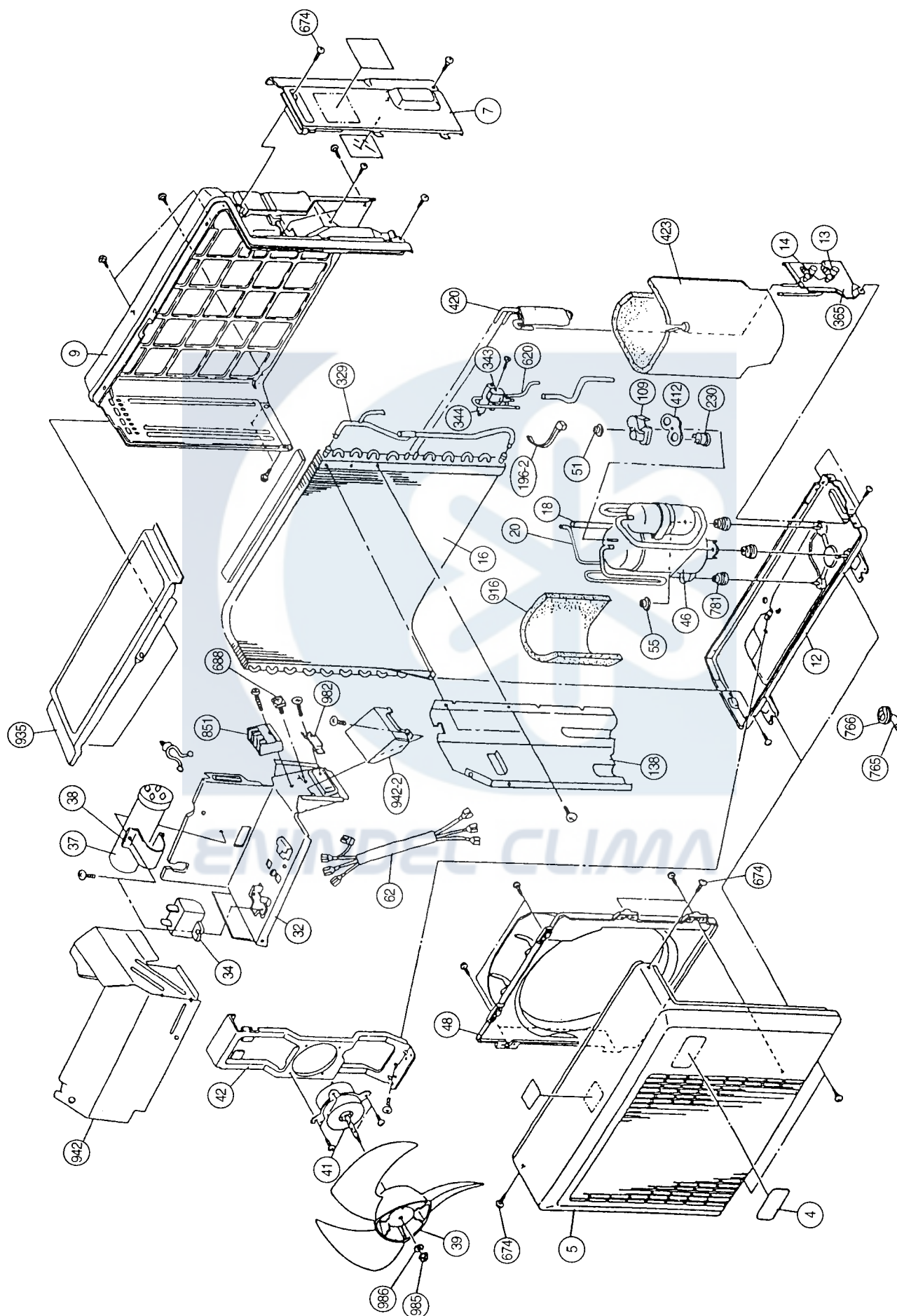

Model : HOW-9UD

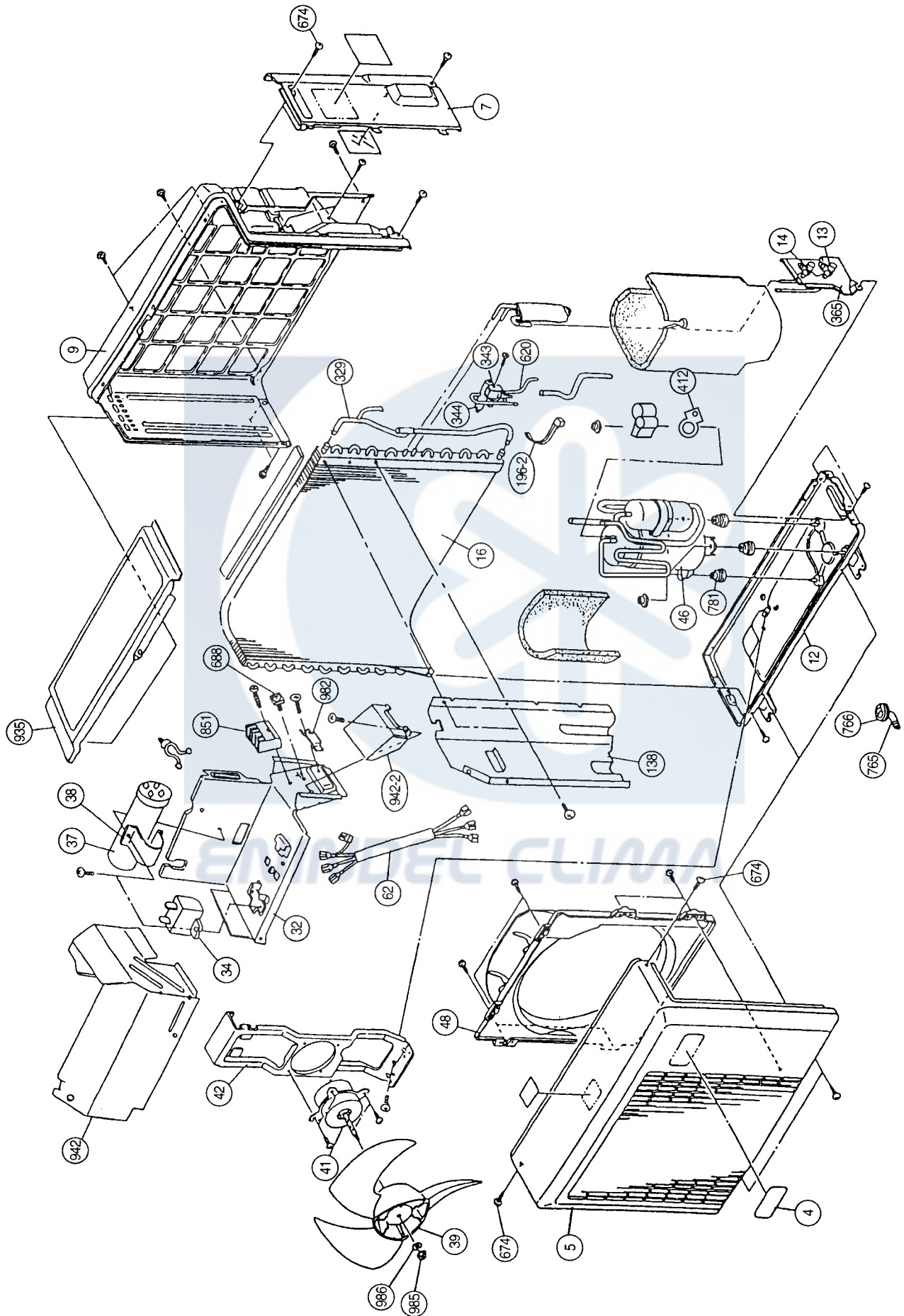

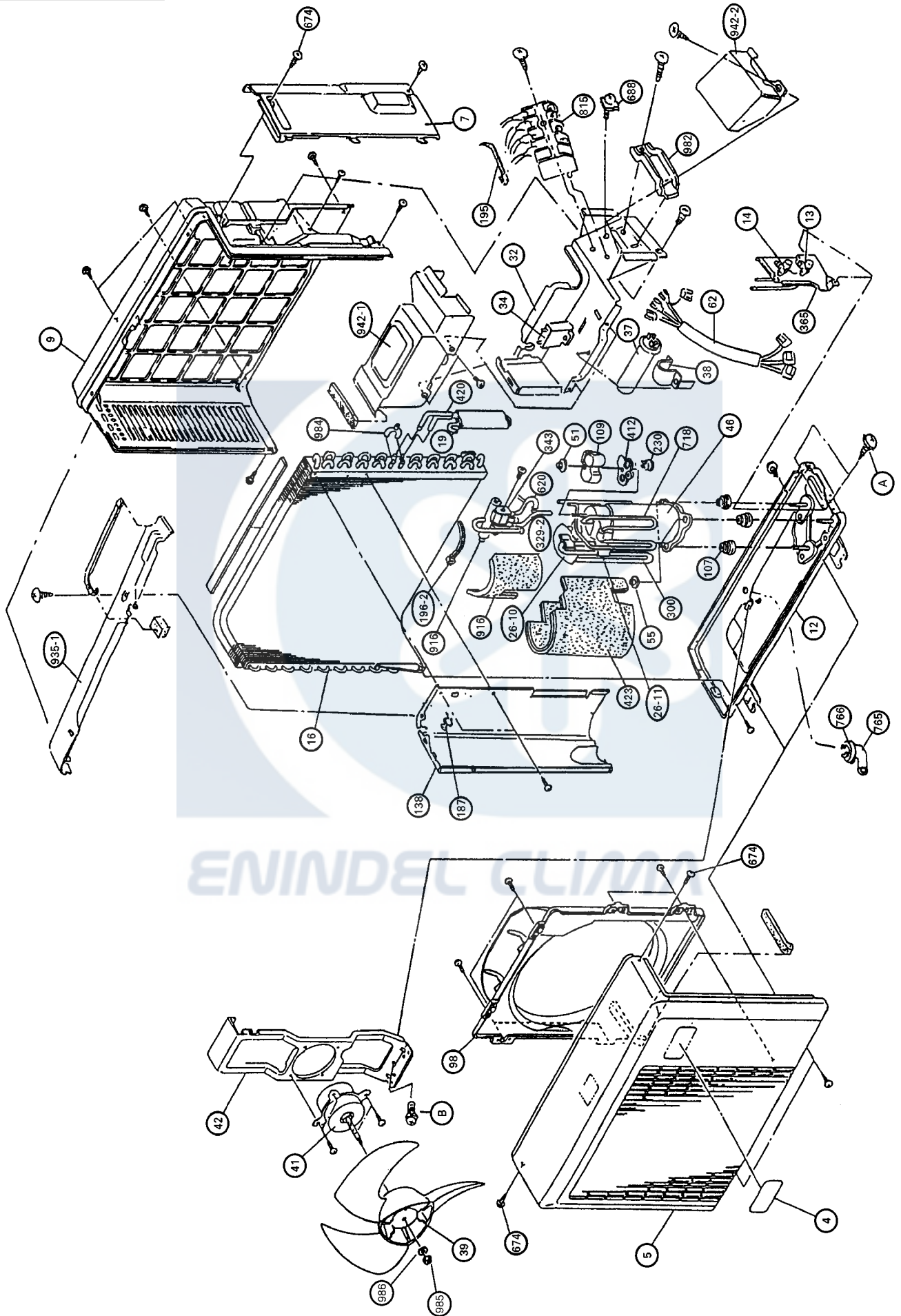

PARTS LIST

INDOOR UNIT





Ref. No.	Description	Part No.		Ord. Q'ty
		HSW-9UC	HSW-12UC	
34	Capacitor (Fan Motor)	9900089061	9900089061	
63	Front Panel	9306050047	9306050047	
65	Flow Control Panel-Z	9306058012	9306058012	
69	Louver-A	9306055028	9306055028	
74	Filter	9305444014	9305444014	
108	Base	9309755062	9309755062	
109	Casing	9306052027	9306052027	
122	Shaft Holder-B	9303066010	9303066010	
127	Drain Hose Assy	9305550029	9305550029	
146	Evaporator Assy	9330144019	9330144019	
151	Control Box	9330007017	9330007017	
158	Connection Pipe Assy	9306416010	9306416010	
164	Fan Motor Assy-IN	9601171010	9601171010	
169	Cross-Flow Fan Assy	9307836015	9307836015	
178	Motor Cushion-M	9601302018	9601302018	
184	Thermistor Spring	313728262708	313728262708	
185	Wire Clamp	9330015012	9330015012	
188	Power Cord Assy	9702595043	9702595043	
196	Clamp SKB-150	313035356905	313035356905	
233	Power Transformer	9900028015	9900028015	
234-1	Thermistor Assy Pipe	9700801115	9700801115	
235	Thermistor Assy-Pipet	9702039059	9702039059	
236	Controller PCB Assy	9706046015	9706046022	
		(K02DE-0400HSE-C1)	(K02DE-0401HSE-C1)	
240	Remote Control Unit	9312058020	9312058020	
281	Clamp Metal (Pipe)	9306063009	9306063009	
283	Bushing-A	9303529010	9303529010	
323	Louver-B	9306056025	9306056025	
385	PCB (Power and Indicator)	9706039017	9706039017	
401	Wall Hook Bracket	9304358008	9304358008	
440	Flow Control Panel-U	9306057015	9306057015	
466	Clamp NK-4N	313714328805	313714328805	
522-1	Gear-A	9306062002	9306062002	
523	Gear Bracket	9306407001	9306407001	
652-1	Thermistor Holder Pipe	313714262805	313714262805	
668	Screw w/Washer	313681304205	313681304205	
687	Earth Terminal	9330012011	9330012011	
759	Intake Grille	9330001015	9330001015	
764	Drain Cap Assy	9304150008	9304150008	
767-1	Bottom Cover-A	9330004016	9330004016	
777	Clamper (Grille)	9306755010	9306755010	
815	Terminal	9900040048	9900040048	
850	Window (Receiver)	9330003019	9330003019	
872	Indicator Case	9330009011	9330009011	
873	Lamp Cover	9330014015	9330014015	
874	Control Box Cover	9330008014	9330008014	
876	Step Motor	9900139018	9900139018	

OUTDOOR UNIT

Ref. No.	Description	Part No.		Ord. Q'ty
		HOW-9UC	HOW-9UD	
4	Emblem-Rear	9312638000	9312638000	
5	Cabinet Front Panel, Plastic	9306016012	9306016012	
7	Connector Cover	9306018016	9306018016	
9	Cabinet Rear Panel, Plastic	9306017019	9306017019	
12	Base Assy, Painted	9304806042	9304806042	
13	3-Way Valve	9312863013	9312863013	
14	2-Way Valve	9312862016	9312862016	
16	Condenser Assy	9309104020	9309104020	
32	Control Box Metal	9306475024	9306475024	
34	Capacitor (Fan Motor)	9900089023	9900089023	
38	Clamp Metal (Capacitor)	313468061808	313468061808	
39	Propeller Fan	9306565015	9306565015	
41	Fan Motor Assy-Out	9307095016	9307095016	
42	Bracket (Motor)	9306021016	9306021016	
46	Compressor Assy	9311012016	9314429019	
48	Fan Ring	9306019020	9306019020	
51	Special Nut M5	9312163007	9312163007	
55	Special Nut M6	9307615016	9307615016	
62	Wire Assy (Shield)-A	9305791026	9305791026	
109	Terminal Cover	9302419008	9302419008	
138	Separate Wall Metal	9306474003	9306474003	
195	Clamp SKB-100	313361275805	313361275805	
196-2	Clamp SKB-3MC	9305335008	9305335008	
230	Overload Relay	9311143000	---	
343	Solenoid Coil	9970003011	9970003011	
344	4-Way Valve	9900162016	9900162016	
365	Bracket (Valve)	9306020026	9306020026	
412	Terminal Gasket (For Comp.)	9351505011	9314432002	
423	Noise Insulation-B	9311106005	9311106005	
582	Discharge Pipe-SF	9306115005	9306115005	
674	Screw, SUS410T+5104	9305848010	9305848010	
688	Screw w/Washer	313681304205	313681304205	
765	Drain Pipe (L-type)	9301102000	9301102000	
766	Drain Pipe packing	9301143003	9301143003	
781	Rubber Cushion	9312680016	9312680016	
815	Terminal-4P	9306488017	9306488017	
820	Joint Pipe (Capillary)	9305680009	9305680009	
935	Reinforcement Plate	9306473006	9306473006	
942	Control Box Cover Metal	9306476007	9306476007	
942-2	Control Box Cover-B Metal	9305975006	9305975006	
982	Cord Clamp, Plastic	9302271002	9302271002	
985	Special Nut w/Washer	9304902003	9304902003	
986	Special Washer	9304903000	9304903000	
A	Screw (with Inner Washer)	9357297002	9357297002	

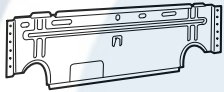
Ref. No.	Description	Part No.	Ord. Q'ty
4	Emblem-Rear	9312638000	
5	Cabinet Front Panel, Plastic	9306386016	
7	Connector Cover	9306119010	
9	Cabinet Rear Panel, Plastic	9306385019	
12	Base Assy, Painted	9306118020	
13	3-Way Valve	9312865017	
14	2-Way Valve	9312864010	
16	Condenser Assy	9308459039	
32	Control Box Metal	9308561022	
34	Capacitor (Fan Motor)	9900089030	
37	Capacitor (Running)	9307588013	
38	Clamp Metal (Capacitor)	313468061808	
39	Propeller Fan	9305538003	
41	Fan Motor Assy-Out	9307715020	
42	Bracket (Motor)	9305536016	
46	Compressor Assy	9314691010	
51	Special Nut M5	9307091001	
55	Special Nut M6	313252257701	
62	Wire Assy (Shield)-A	9305971026	
98	Fan Ring	9305581023	
107	Rubber Seat-A	9351813017	
109	Terminal Cover	9307090004	
138	Separate Wall Metal	9305971008	
187	Clamp No.1219	313361271706	
195	Clamp SKB-100	313361275805	
196	Clamp SKB-150	313035356905	
196-2	Clamp SKB-3MC	9305335008	
230	Overload Relay	9312899005	
329	Coupling Pipe Assy	9306400002	
329-2	Coupling Pipe-C	9306433000	
343	Solenoid Coil	9970003011	
344	4-Way Valve	9900162016	
365	Bracket (Valve)	9306748012	
412	Terminal Gasket (For Comp.)	9351121006	
582	Discharge Pipe-SF	9306115005	
674	Screw, SUS410T+5104	9305848010	
688	Screw w/Washer	313681304205	
765	Drain Pipe (L-type)	9301102000	
766	Drain Pipe packing	9301143003	
815	Terminal-4P	9306488017	
420	Capillary Assy	9312873005	
916	Noise Insulation-A	9306362003	
935-1	Reinforcement (Cabinet Top)	9305973002	
935-2	Rereinforcement-F (Cabinet Top)	9306123000	
942-1	Control Box Cover-A Metal	9308562012	
942-2	Control Box Cover-B Metal	9305975006	
946	Inlet Pipe	9306401009	
982	Cord Clamp, Plastic	9302271002	
985	Special Nut w/Washer	9304902003	
986	Special Washer	9304903000	
A	Screw (with Inner Washer)	9357297002	
B	Screw (with Spring Washer)	0700179013	

STANDARD ACCESSORIES

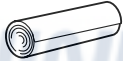
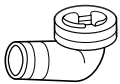
Name and Shape	Part No.	
	HSW-9UC	HSW-12UC
Wall hook bracket 	9304358008	9304358008
Remote control unit 	9312058020	9312058020
Battery (penlight) 	0600185534	0600185534
Tapping screw (Ø4 x 25) 	0700076046	0700076046
Cloth tape 	9308117007	9308117007
Drain pipe (Including drain packing) 	9303029015	9303029015



HIYASU, S.A.

Calle Brasil, 52-54 08028 Barcelona

0309G2372

WWW.ENINDEL.COM