



HIGH POWER MULTI AIR CONDITIONER WALL MOUNTED CASSETTE type

SERVICE MANUAL



Models

Indoor unit

HSM-12UA
HSM-7UA

Outdoor unit

HOM-20U2A

HUM-12UA
HSM-7UA

HOM-20U2A

CONTENTS

SPECIFICATIONS	1
OUTLINE AND DIMENSIONS	2
REFRIGERANT SYSTEM DIAGRAM	4
ERROR DISPLAY	5
CIRCUIT DIAGRAM	7
INDOOR PRINTED CIRCUIT BOARD CIRCUIT DIAGRAM	9
OUTDOOR PRINTED CIRCUIT BOARD CIRCUIT DIAGRAM ..	11
DISASSEMBLY ILLUSTRATION	12
PARTS LIST	23

SPECIFICATIONS

TYPE	COOL & HEAT		
INDOOR UNIT	HSM-12UA	HSM-7UA	HUM-12UA
OUTDOOR UNIT	HOM-20U2A		
COOLING CAPACITY (kW)	3.45	2.25	3.50
HEATING CAPACITY (kW)	4.00	2.70	4.00

COOL & HEAT	
HSM-12UA + HSM-7UA	HUM-12UA + HSM-7UA
HOM-20U2A	
5.70	5.75
6.70	6.70

ELECTRICAL DATA

POWER SOURCE (V)	230			
FREQUENCY (Hz)	50			
RUNNING CURRENT (A)	COOLING	5.8	3.9	5.8
	HEATING	6.2	4.1	6.2
INPUT WATTS (kW)	COOLING	1.32	0.87	1.32
	HEATING	1.40	0.90	1.40
E.E.R. (kW/kW)	COOLING	2.61	2.59	2.65
	HEATING	2.86	3.00	2.86
MOISTURE REMOVAL (ℓ/hr)	1.3	1.0	1.3	
AIR CIRCULATION-Hi (m³/hr)	520	420	550	

230	
50	
9.5	9.5
9.4	9.4
2.13	2.13
2.09	2.09
2.68	2.70
3.21	3.21
2.3	2.3
3,000 (Outdoor unit)	3,000 (Outdoor unit)

COMPRESSOR (Two compressors in one outdoor unit)

TYPE	Hermetic type, Permanent split condenser, 2 pole, Single phase, Induction motor, Rotary		
POWER SOURCE	230V 50Hz		
DISCRIMINATION	802-354-35B	802-100-65B	
REFRIGERANT R410A (g)	1,000	800	

FAN MOTOR

POWER SOURCE (V)	230			
INDOOR UNIT COOL (HEAT)	HI-SPEED (r.p.m.)	1,310 (1,310)	1,250 (1,270)	760 (760)
	MED-SPEED (r.p.m.)	1,260 (1,180)	1,140 (1,140)	690 (690)
	LO-SPEED (r.p.m.)	1,190 (1,030)	1,070 (1,030)	610 (610)
	QUIET (r.p.m.)	1,100 (970)	1,000 (970)	-
OUTDOOR UNIT	HI-SPEED (r.p.m.)	750		
	LO-SPEED (r.p.m.)	450		

DIMENSIONS

INDOOR UNIT H x W x D (mm)	257 x 808 x 187	235 x 580 x 580 + 70
OUTDOOR UNIT	700 x 900 x 350	

WEIGHT

INDOOR UNIT GROSS / NET (kg)	10 / 8	23 / 18
OUTDOOR UNIT	74 / 68	

OUTLINE AND DIMENSIONS

INDOOR UNIT

Unit : mm

Models : HSM-12UA
HSM-7UA

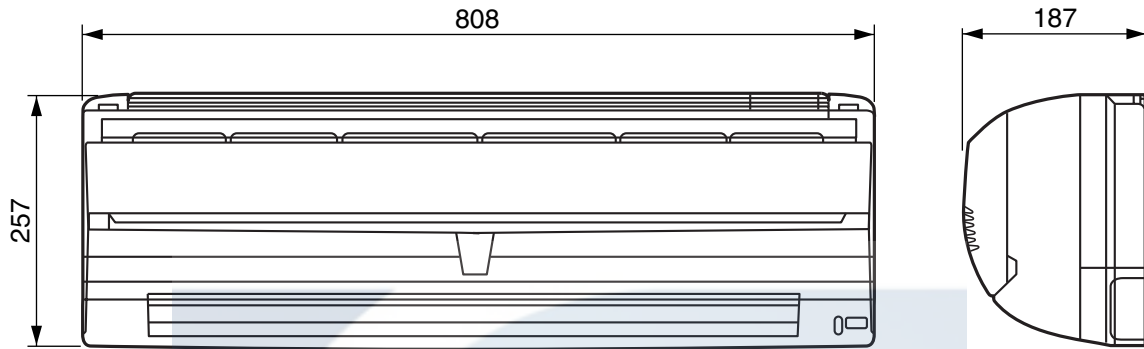

OUTDOOR UNIT

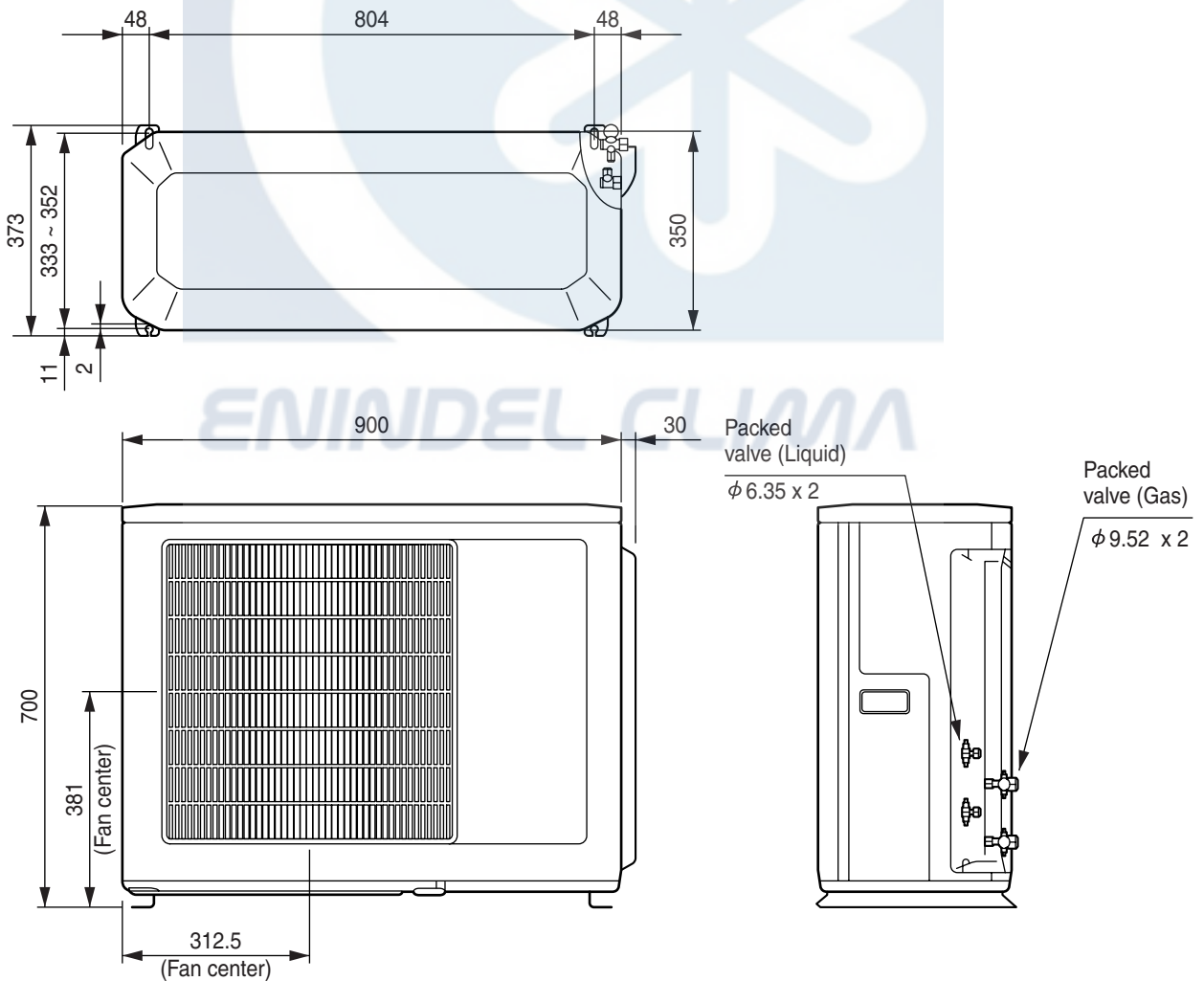

INDOOR UNIT (Cassette type)

(unit : mm)

Model : HUM-12UA

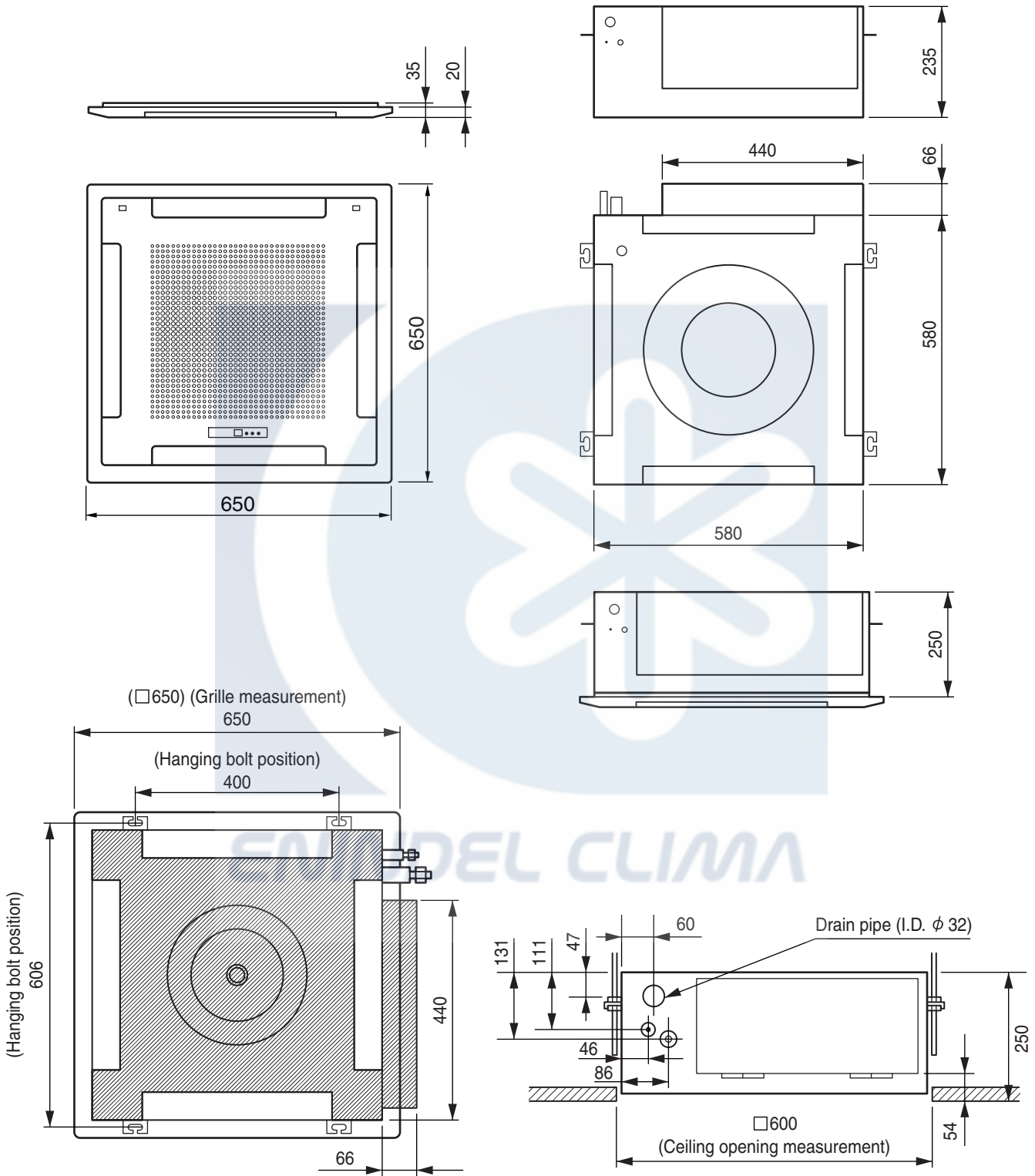

REFRIGERANT SYSTEM DIAGRAM

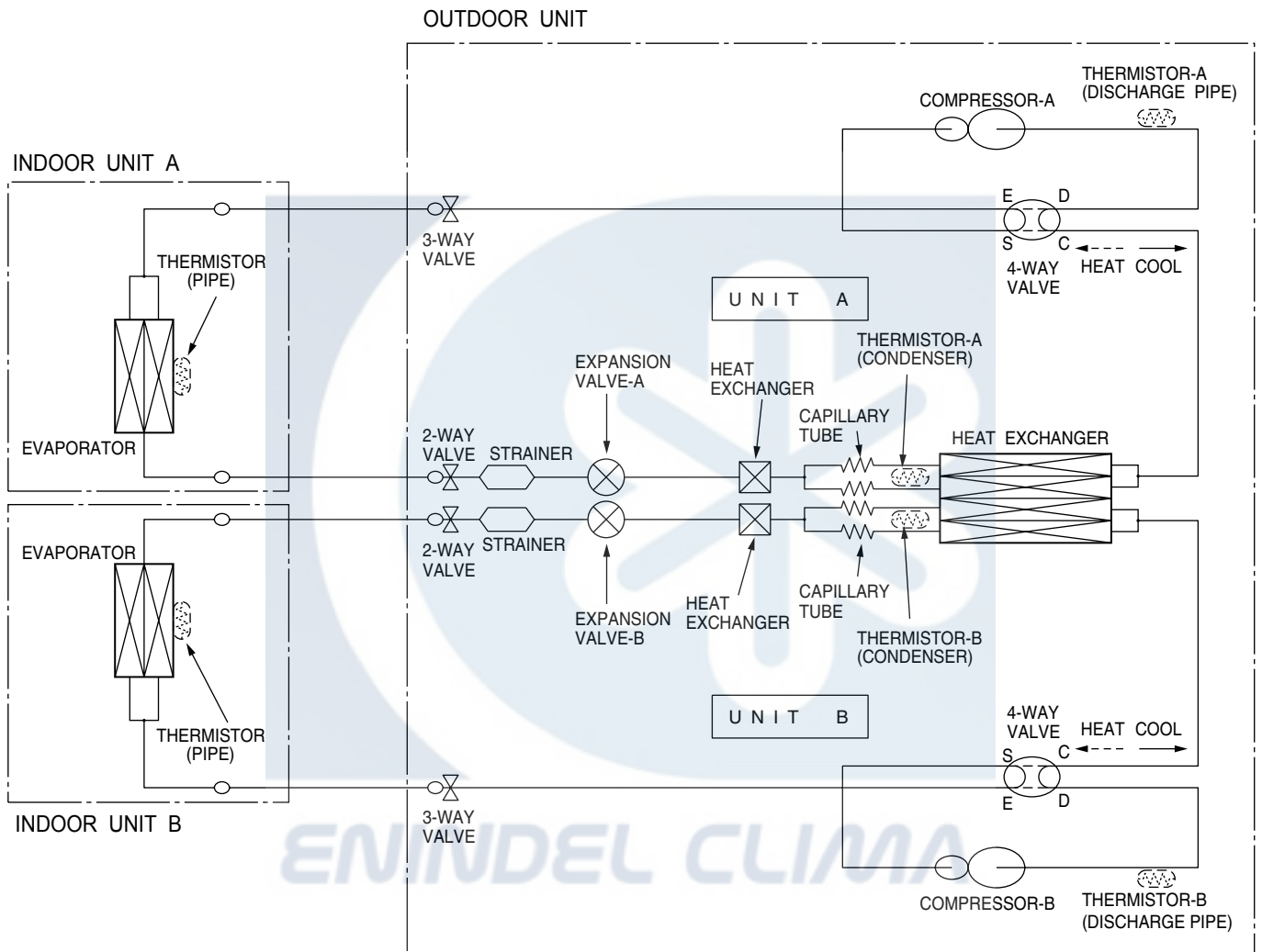

CIRCUIT DIAGRAM

Models : HSM-12UA
HSM-7UA
HOM-20U2A

INDOOR UNIT

OUTDOOR UNIT

UNIT A

UNIT B

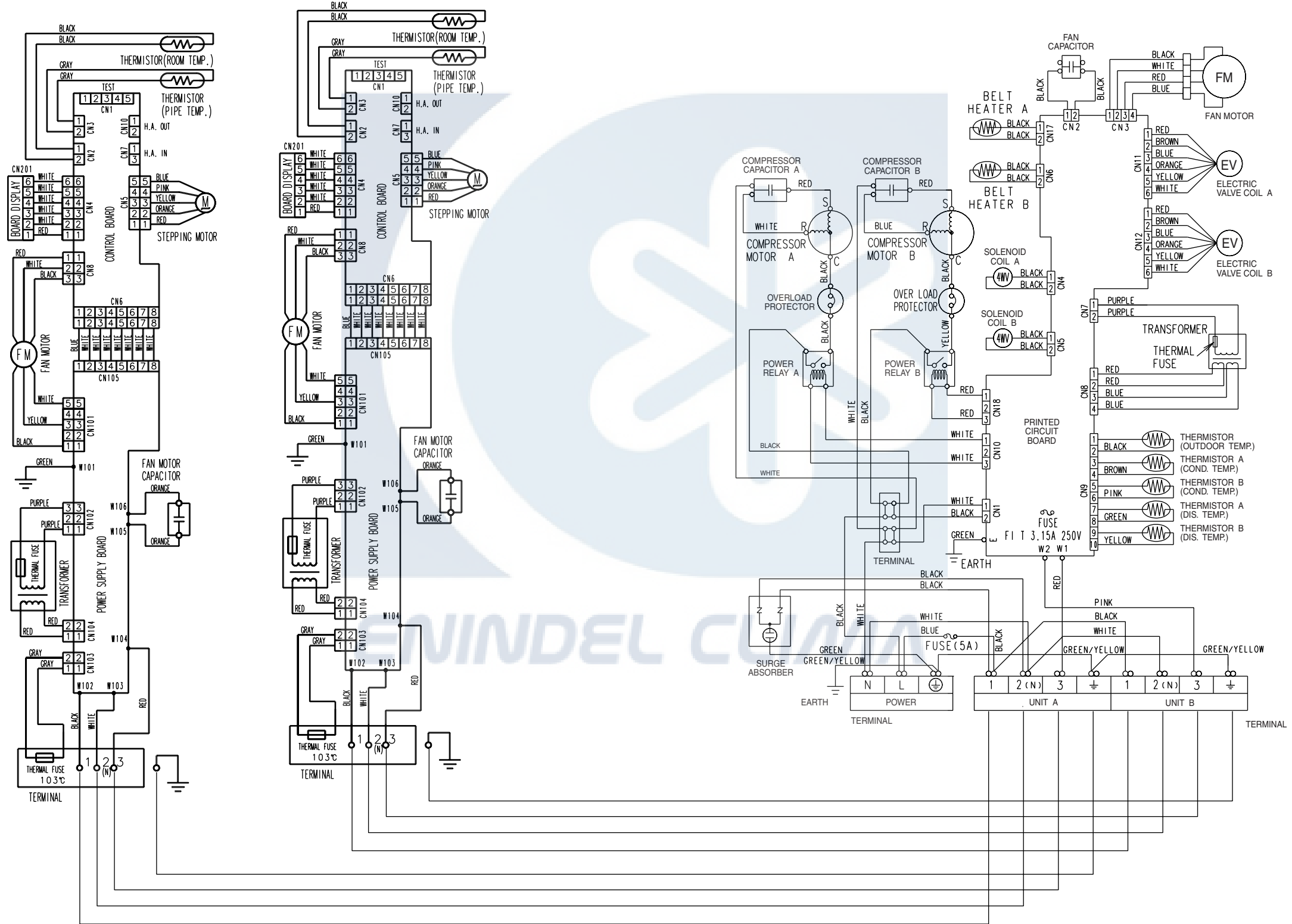

Models : HUM-12UA
HSM-7UA
HOM-20U2A

INDOOR UNIT

OUTDOOR UNIT

Cassette type

Wall Mounted type

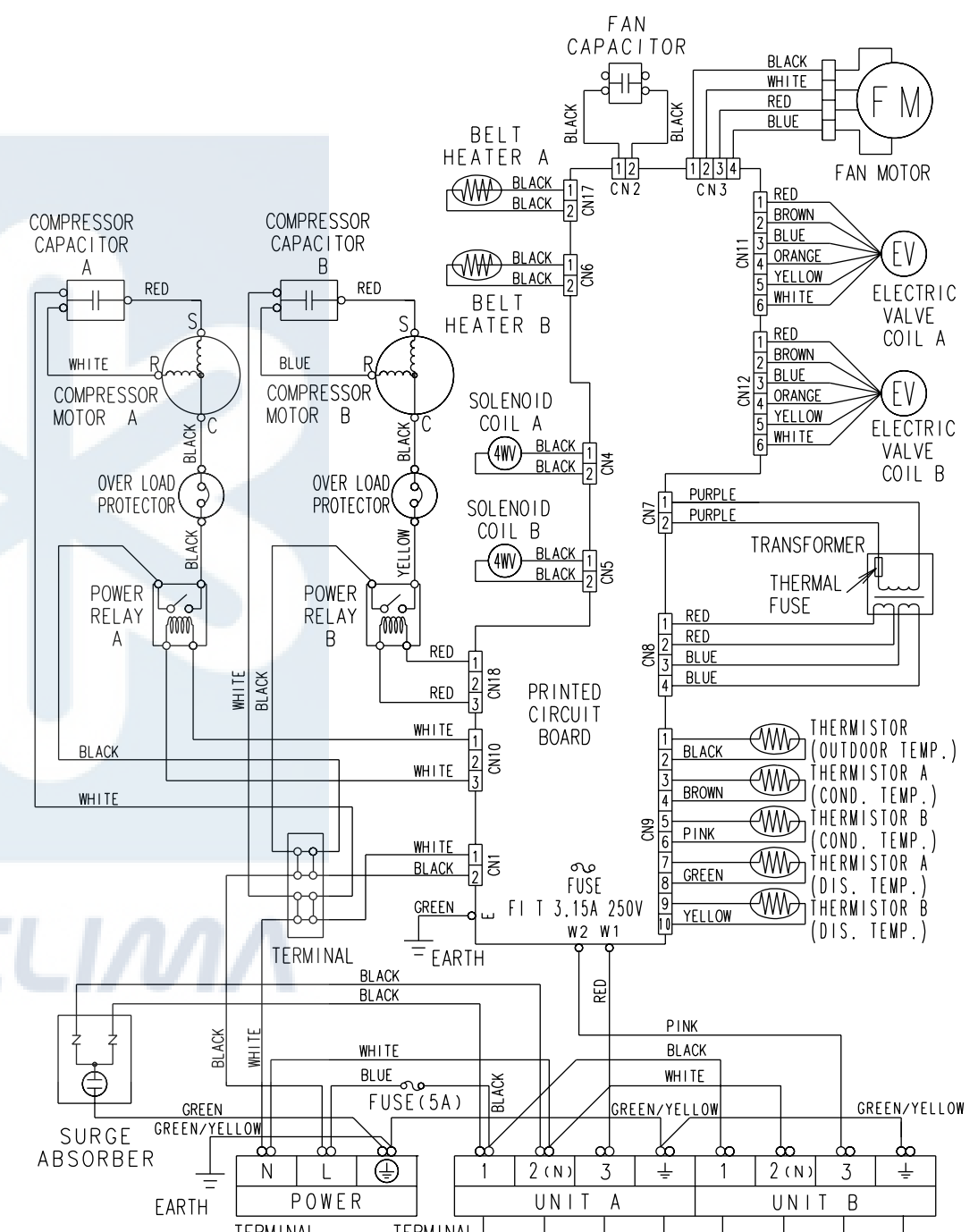
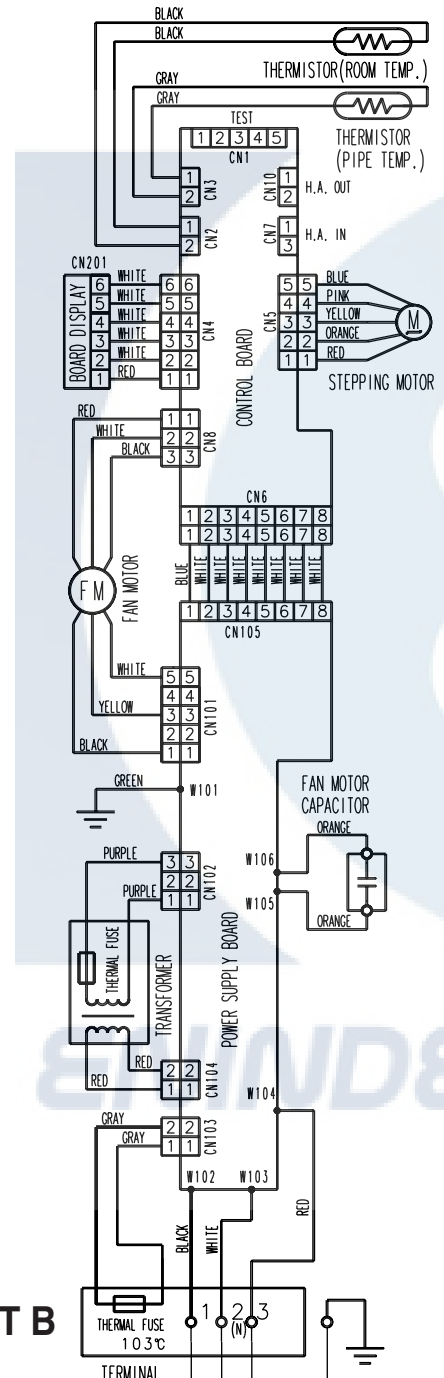
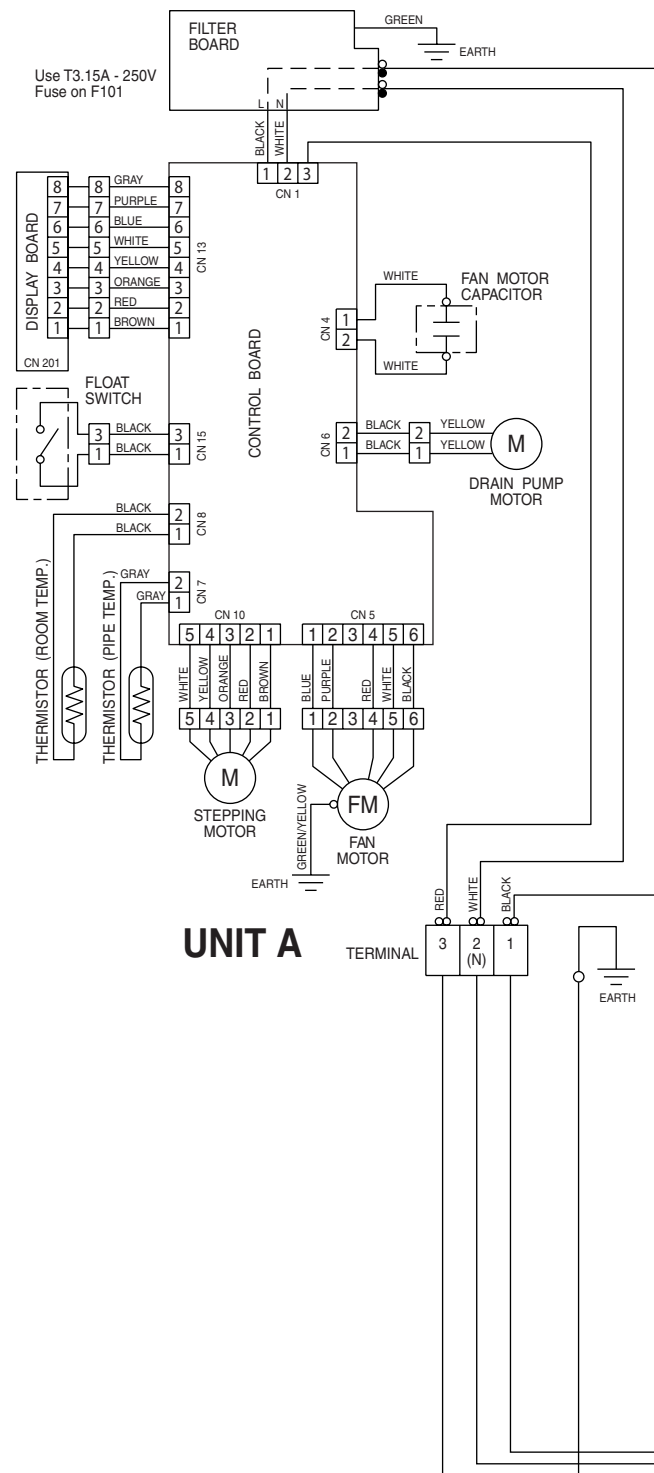

INDOOR PRINTED CIRCUIT BOARD CIRCUIT DIAGRAM

Models : HSM-12UA
HSM-7UA

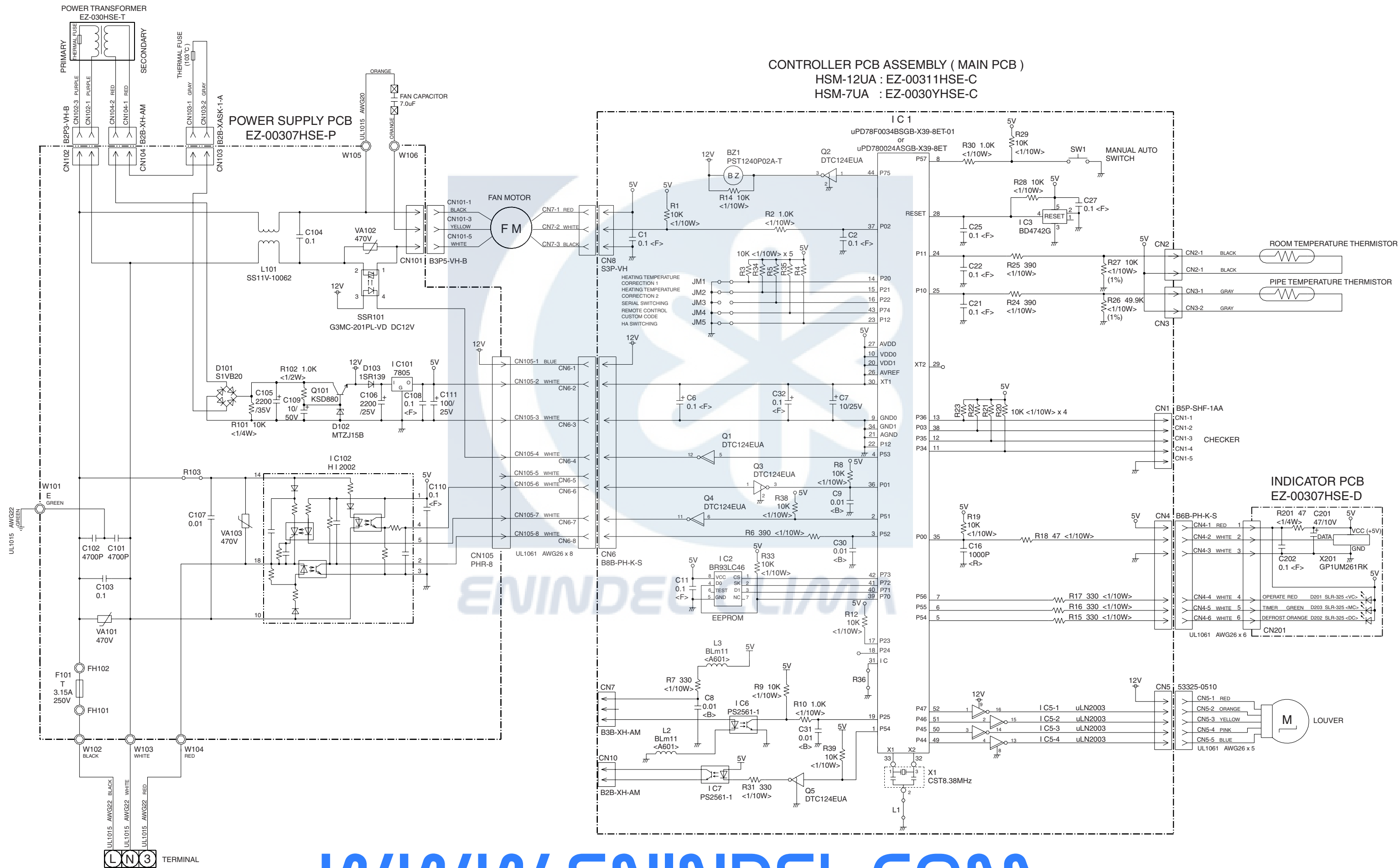

CONTROLLER PCB ASSEMBLY (MAIN PCB)
EZ-0032EHSE-C

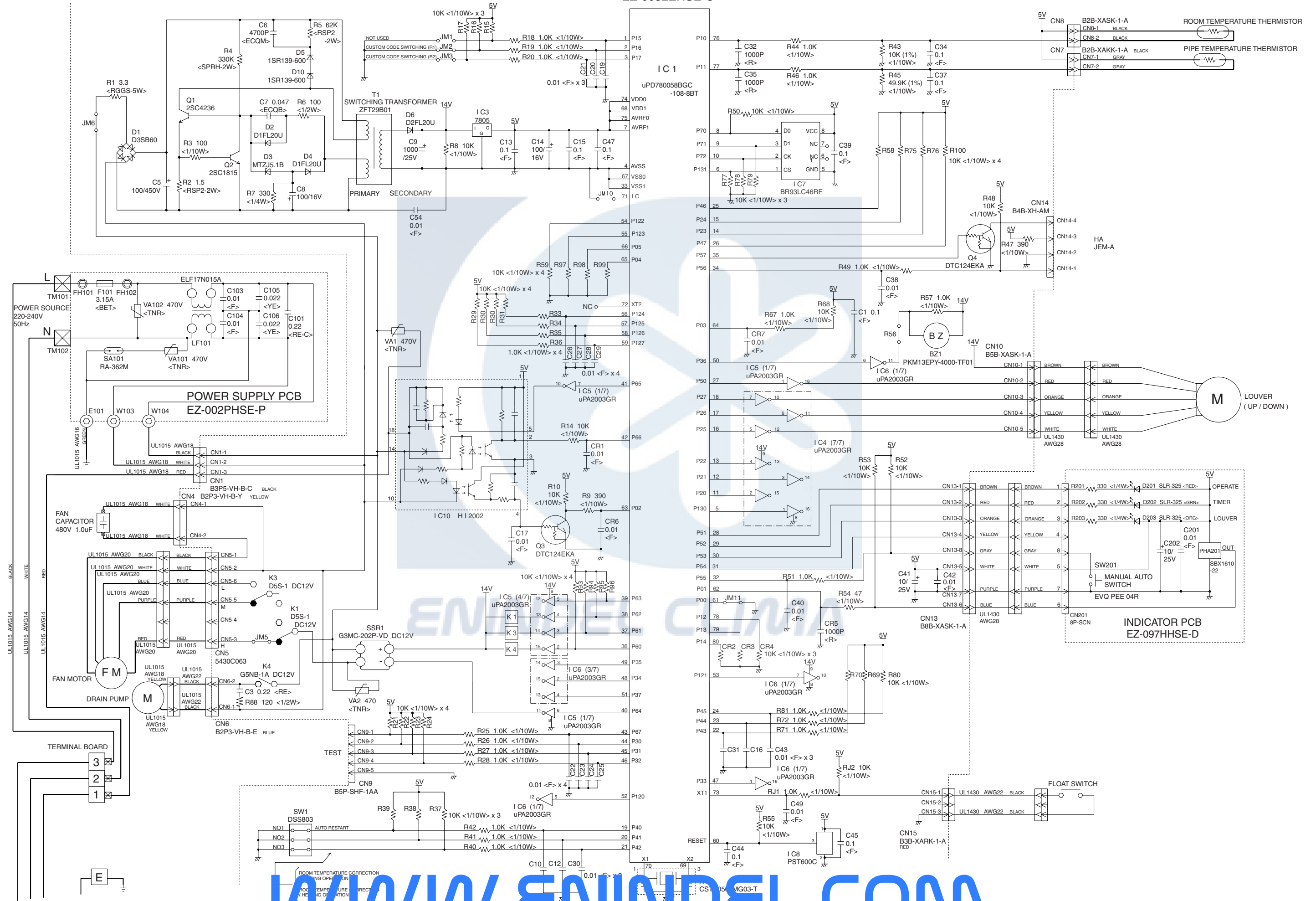

OUTDOOR PRINTED CIRCUIT BOARD CIRCUIT DIAGRAM

Model : HOM-20U2A

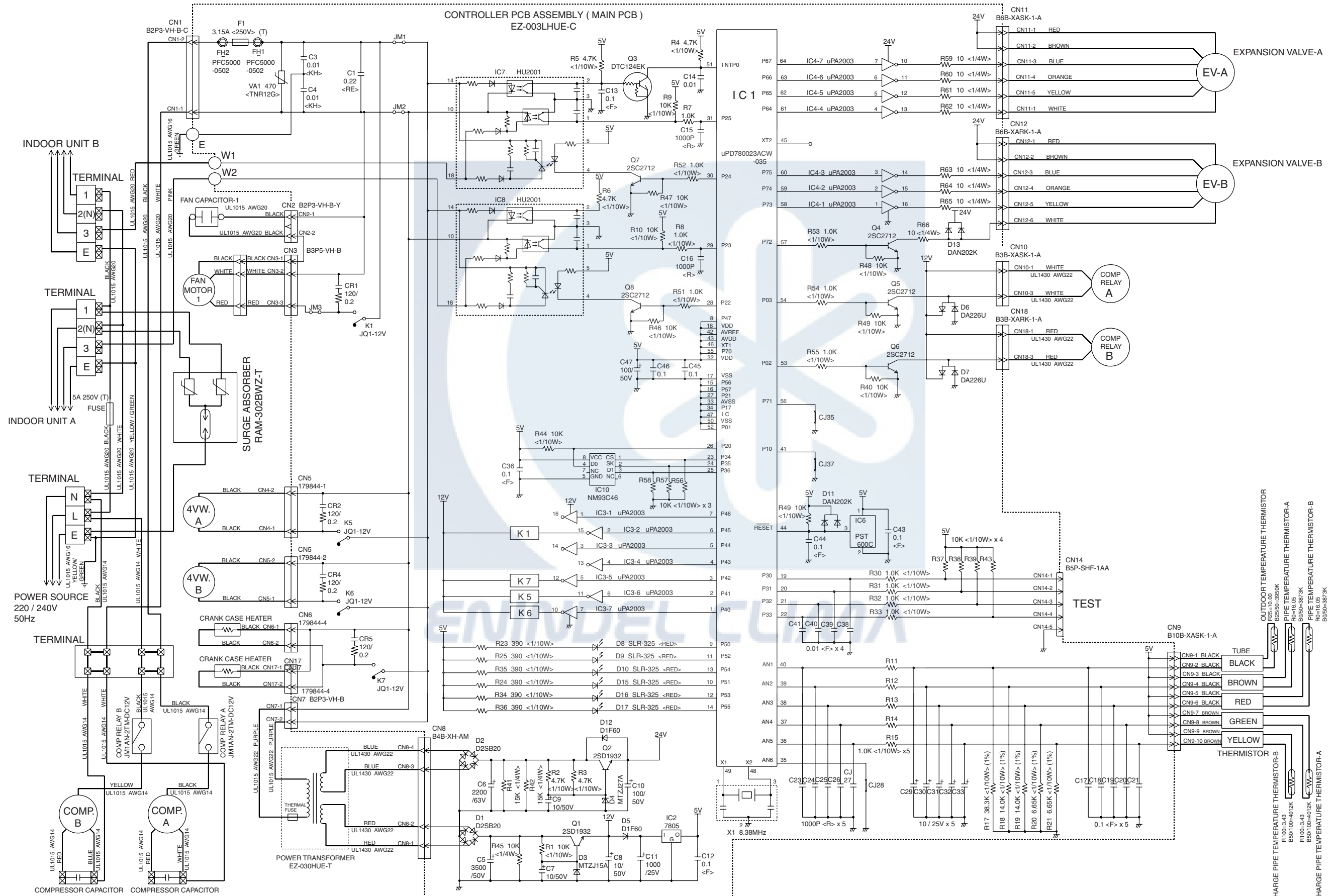

DISASSEMBLY ILLUSTRATION

Models : HSM-12UA
HSM-7UA

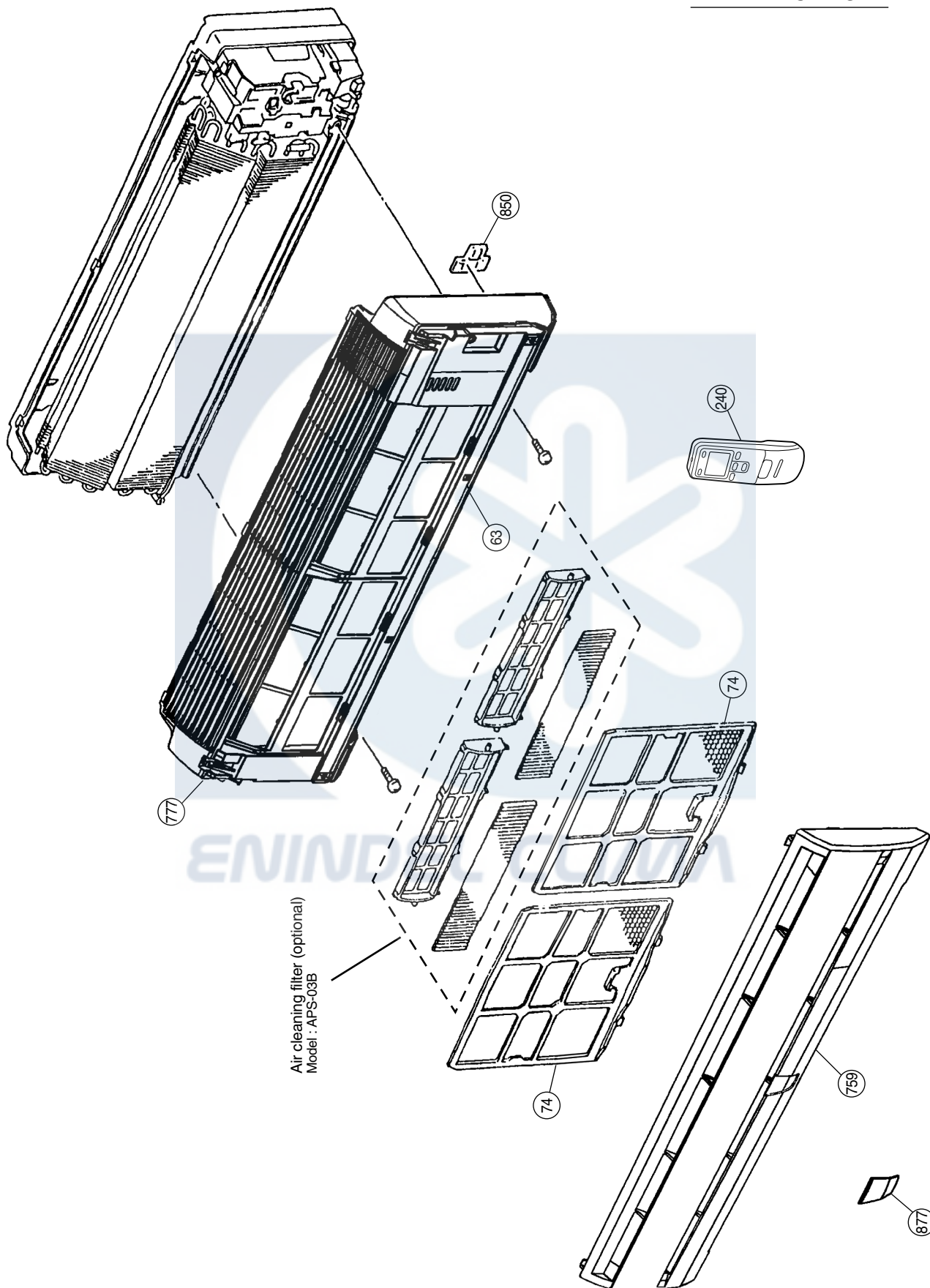

Model: HSM-12UA

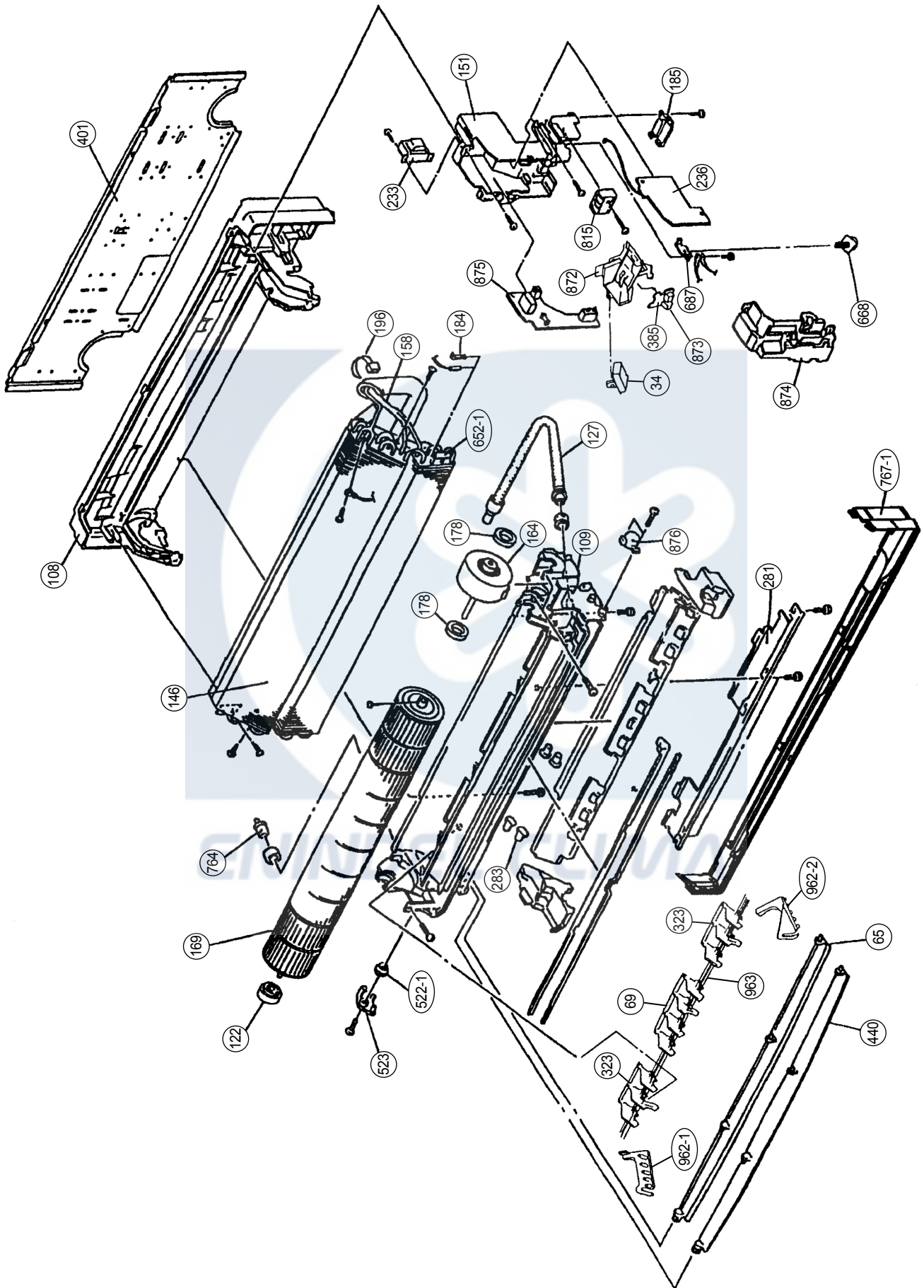

Model : HSM-7UA

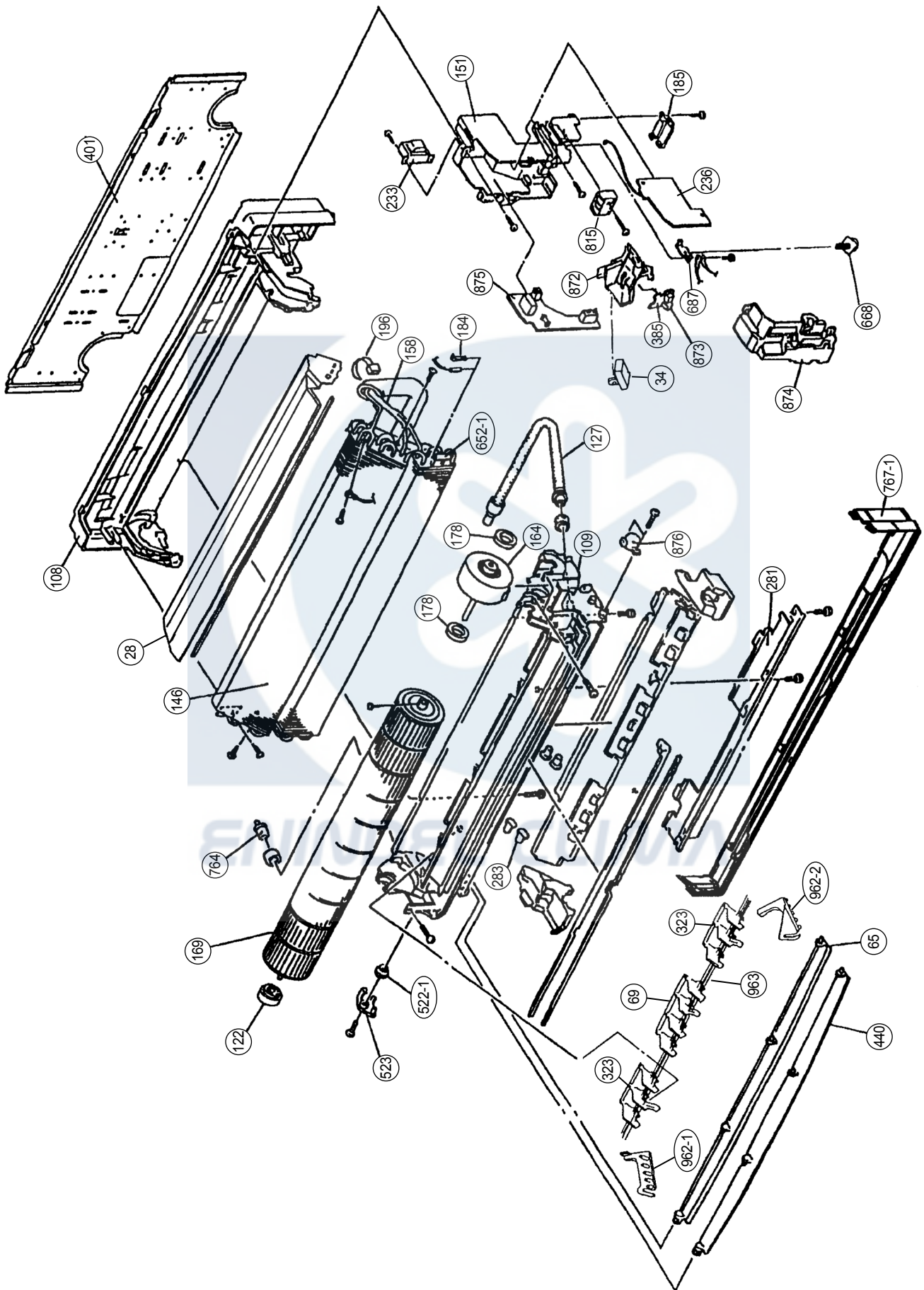

Model : HUM-12UA

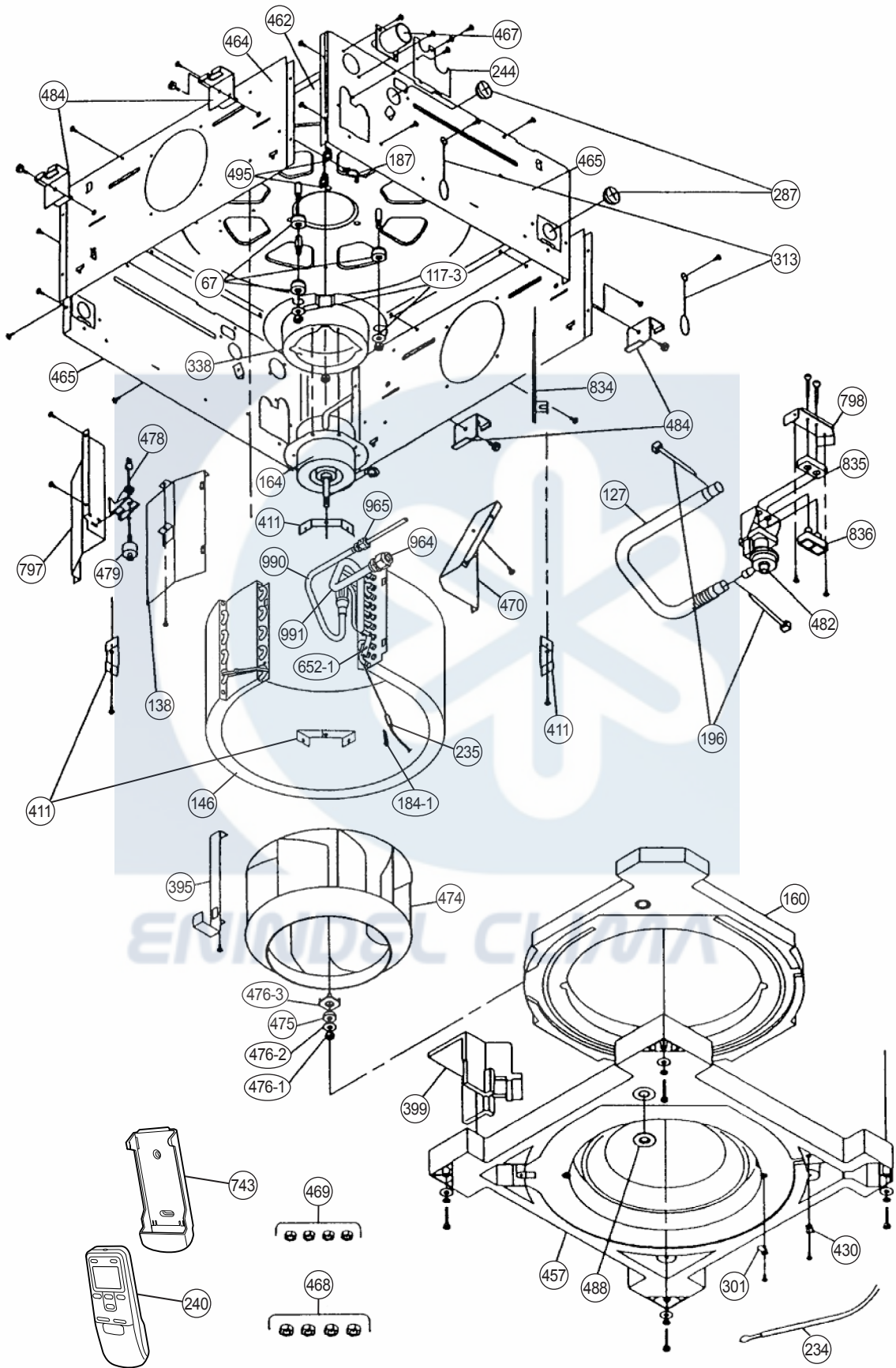

Model : HUM-12UA

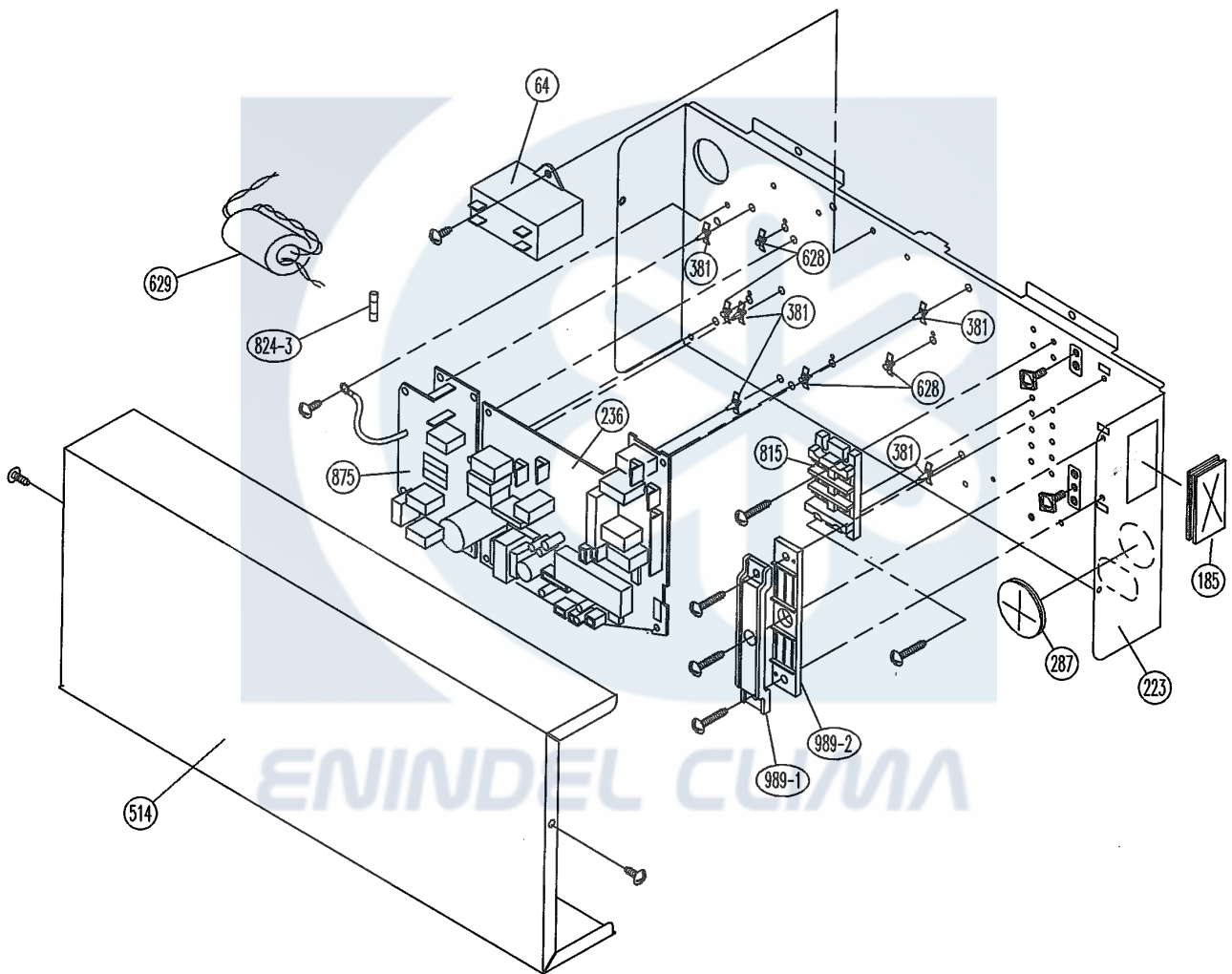

Models : UTG-UDGD-W
UTG-UDYD-W

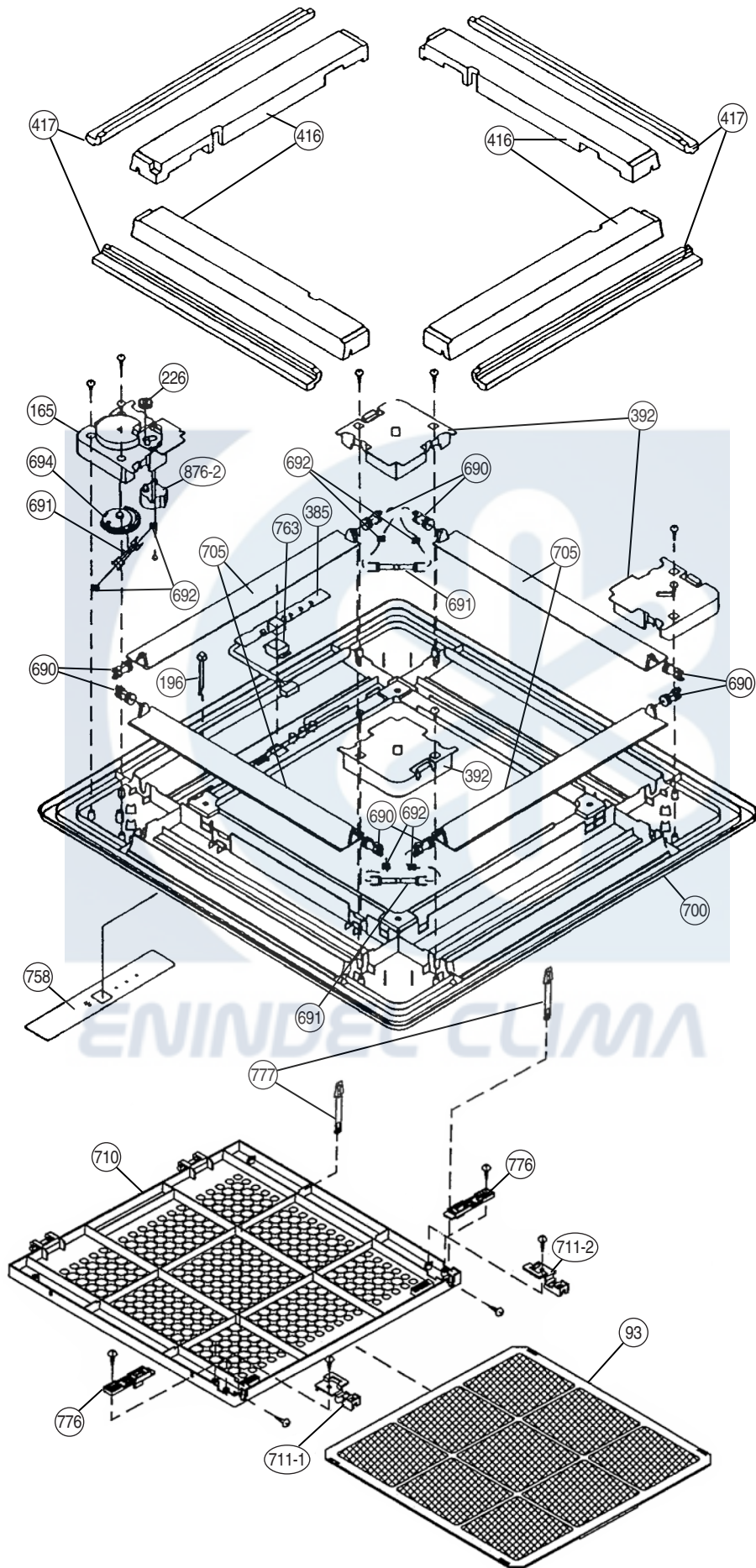

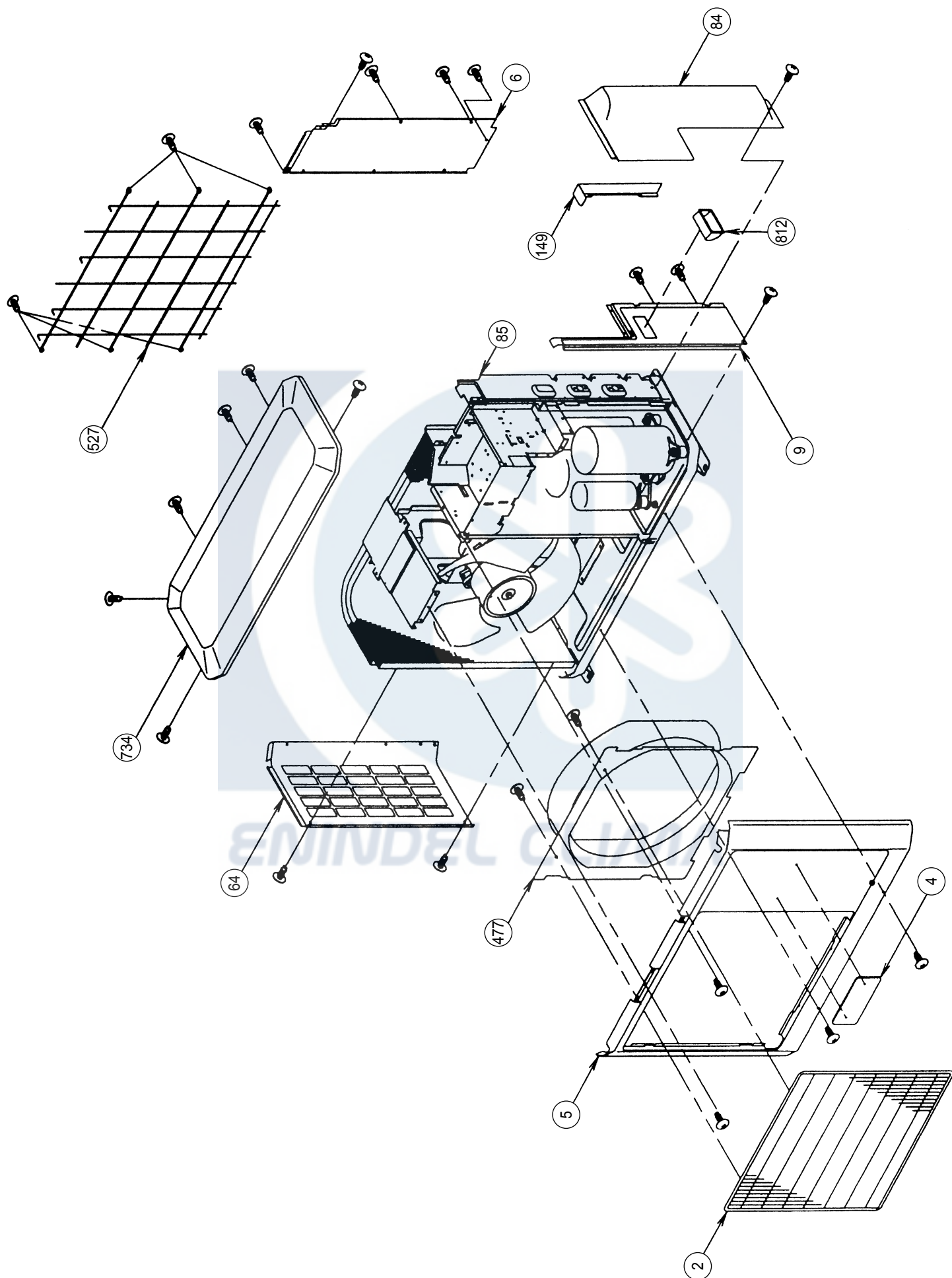

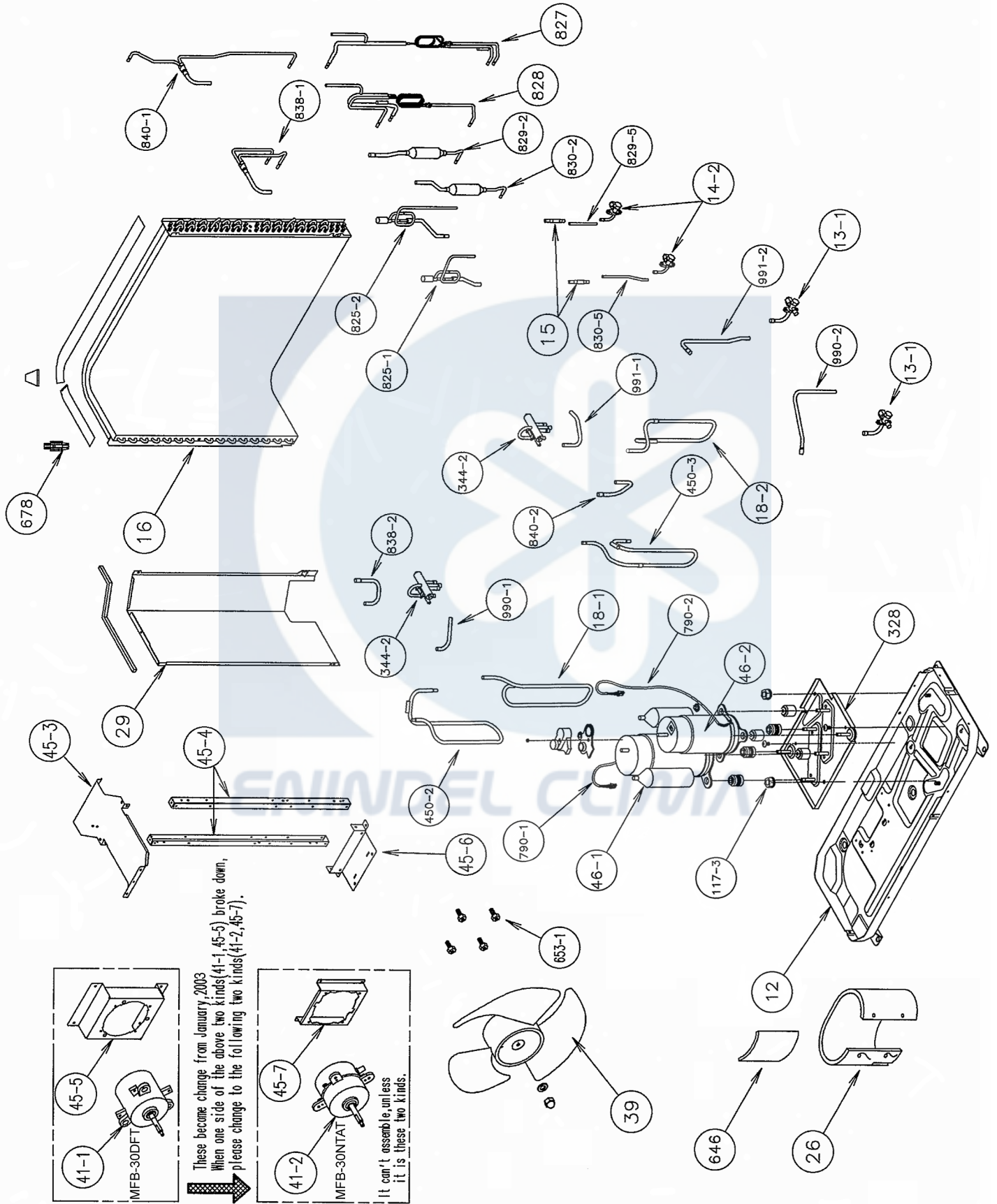

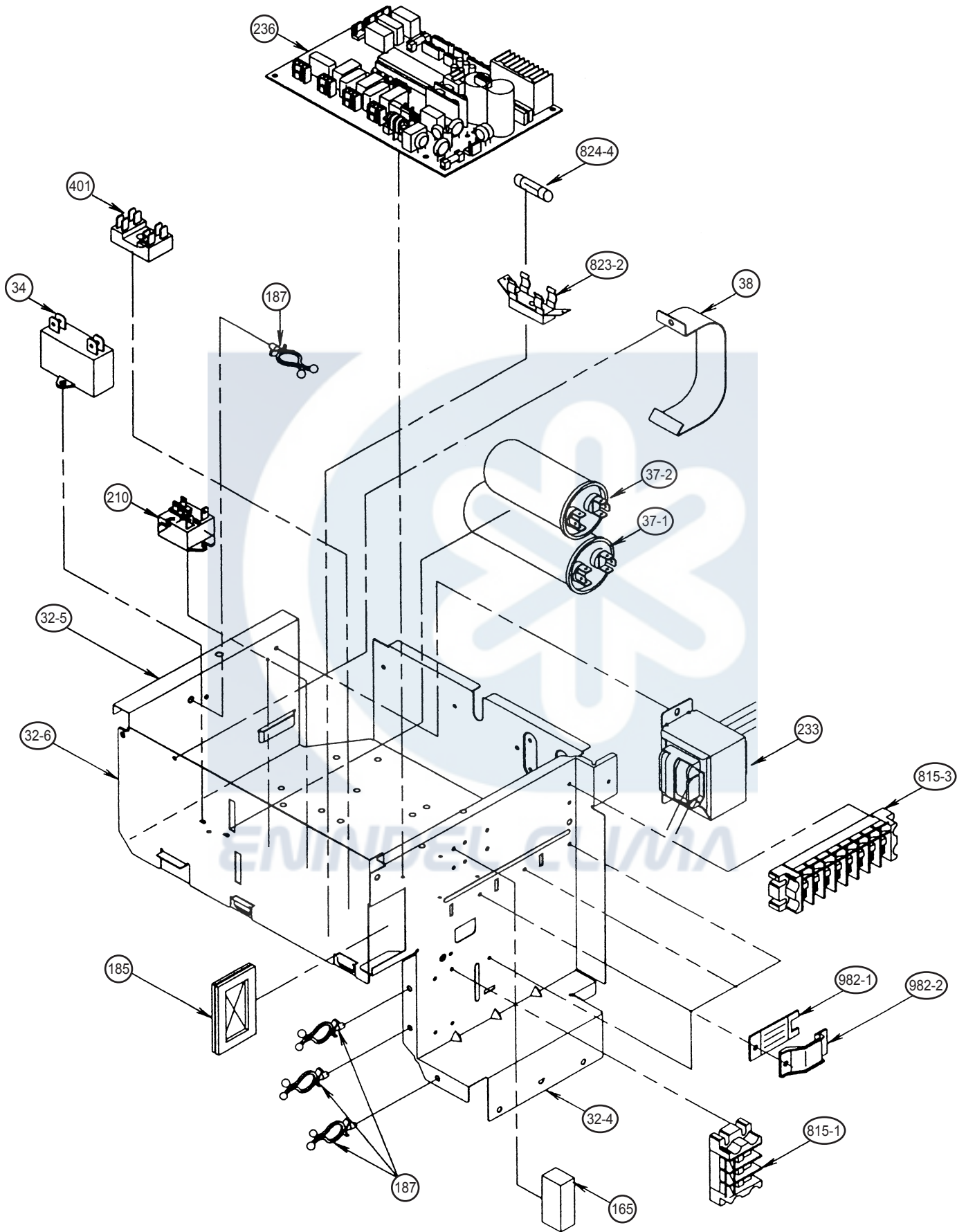

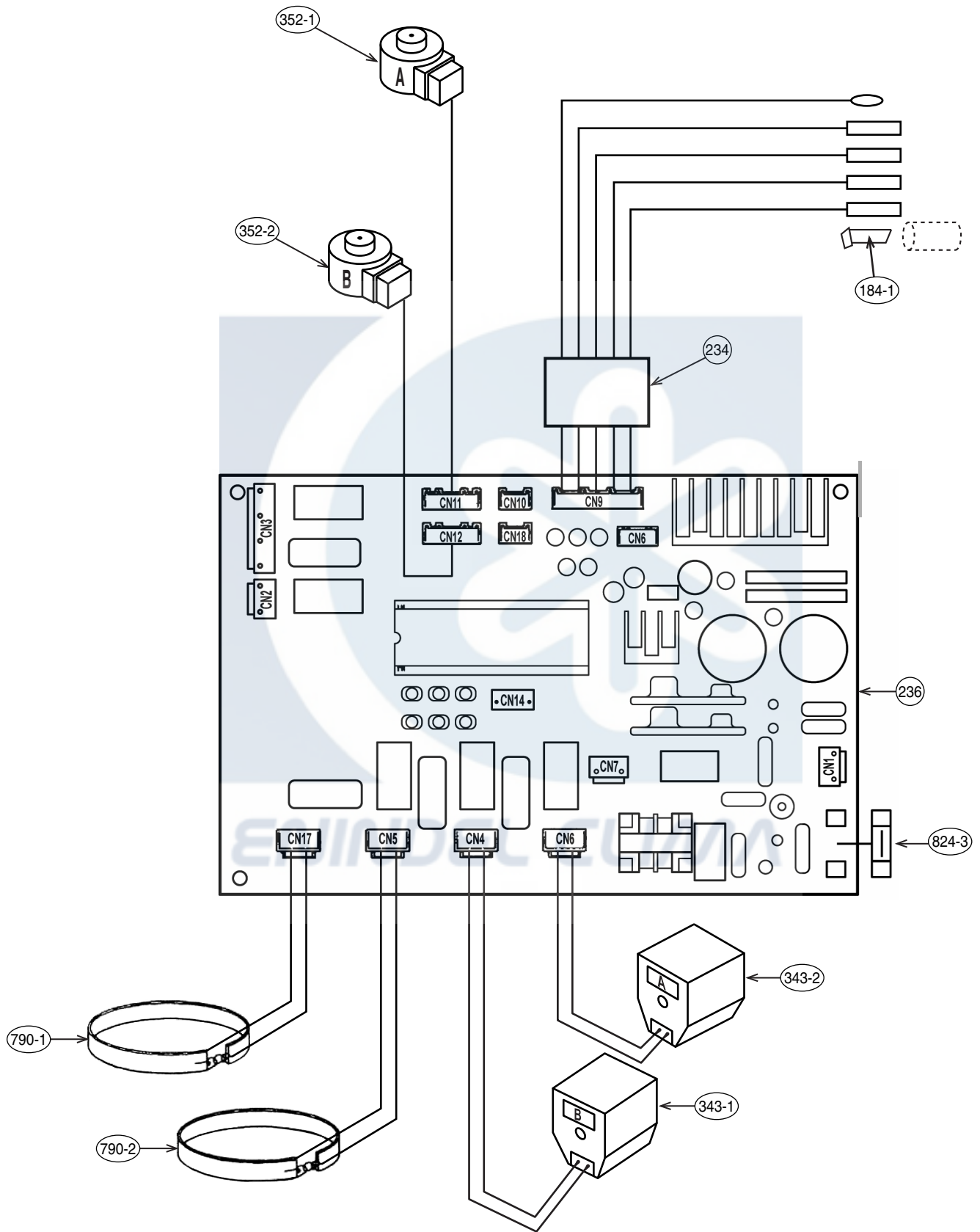

Model : HOM-20U2A

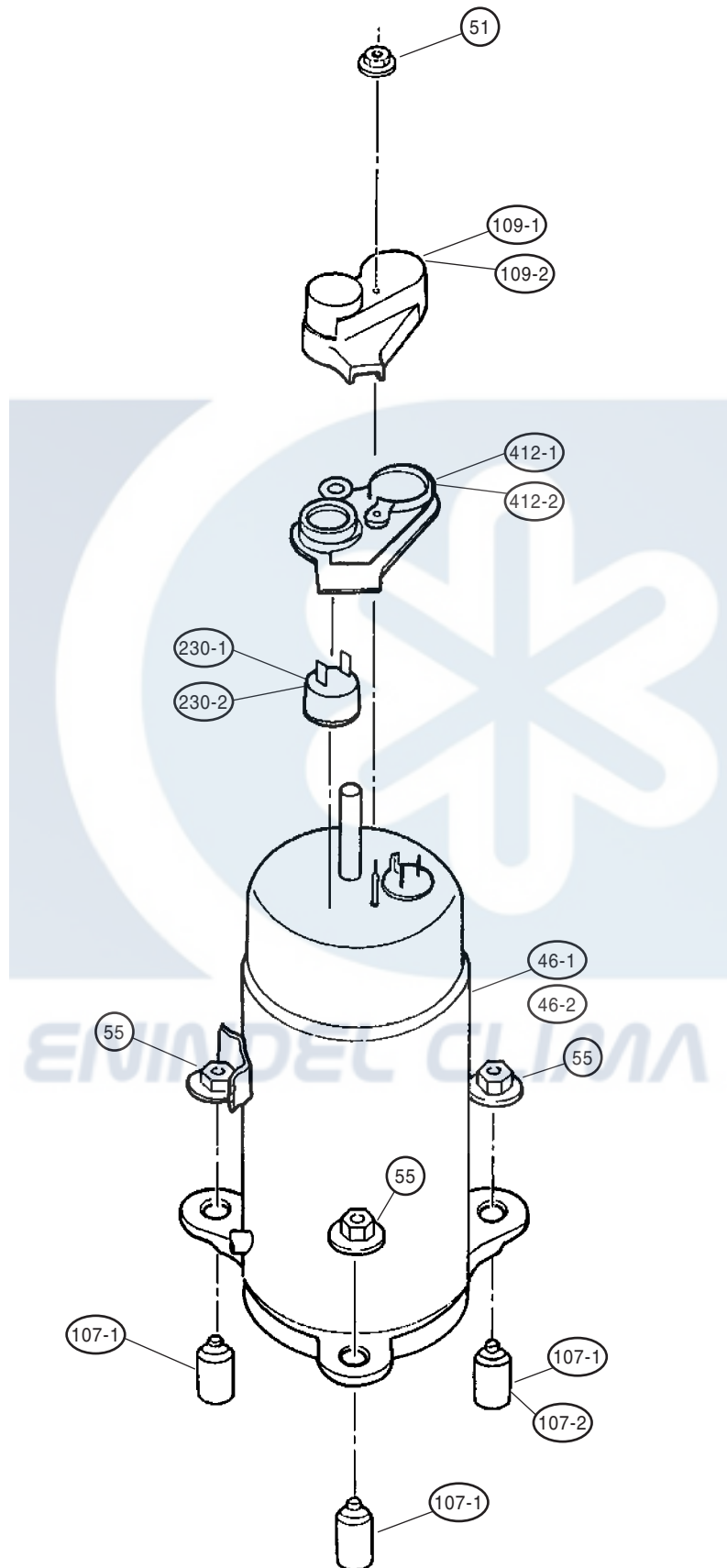

PARTS LIST

INDOOR UNIT

Ref. No.	Description	Part No.		Ord. Q'ty
		HSM-12UA	HSM-7UA	
28	Blower Cover	-----	9306462000	
34	Capacitor (Fan motor)	9900089061	9900089061	
63	Front Panel Assy	9312172184	9312172184	
65	Flow Control Panel-Z	9306058043	9306058043	
69	Louver-A	9306055028	9306055028	
74	Filter	9305444014	9305444014	
108	Base	9309755062	9309755062	
109	Casing	9306052027	9306052027	
122	Shaft Holder-B	9303066010	9303066010	
127	Drain Hose Assy	9305550029	9305550029	
146	Evaporator Assy	9373044017	9308559036	
151	Control Box	9330007017	9330007017	
158	Connecting Pipe Assy	9306416010	9306698003	
164	Fan Motor Assy-IN	9601172017	9601172017	
169	Cross-Flow Fan Assy	9307836015	9307836015	
178	Motor Cushion-M	9601302018	9601302018	
184	Thermistor Spring	313728262708	313728262708	
185	Wire Clamp	9330015012	9330015012	
196	Clamp SKB-150	313035356905	313035356905	
233	Power Transformer	9701803026	9701803026	
236	Controller PCB Assy	9705289062	9705289048	
240	Remote Control Unit	9307113055	9307113055	
281	BRACKET(PIPE)	9330011014	9330011014	
283	Bushing-A	9303529010	9303529010	
323	Louver-B	9306056025	9306056025	
385	Indicator PCB Assy	9705296015	9705296015	
401	Wall Hook Bracket	9304358008	9304358008	
440	Flow Control Panel-U	9306057046	9306057046	
522-1	Gear-A	9306062002	9306062002	
523	Gear Bracket	9306407001	9306407001	
652-1	Thermistor Holder Pipe	313714262805	313714262805	
668	Screw w/Washer	313681304205	9330012011	
687	Earth Terminal	9330012011	313681304205	
759	Intake Grille	9330002036	9330002036	
764	Drain Cap Assy	9304150008	9304150008	
767-1	Bottom Cover	9330004016	9330004016	
777	CLAMPER(GRILL)	9306755010	9306755010	
815	Terminal	9900040055	9900040055	
850	Window (Receiver)	9330003019	9330003019	
872	Indicator Case	9330009011	9330009011	
873	Lamp Cover	9330014015	9330014015	
874	Control Box Cover	9330008014	9330008014	
875	Power Supply PCB Assy	9705294011	9705294011	
876	Step Motor	9900139018	9900139018	
962-1	Guard Holder-L	9306678012	9306678012	
962-2	Guard Holder-R	9306677015	9306677015	
963	Fan Guard	9305751013	9305751013	

When you order parts, please make a photocopy of this page and fill the number of the parts in the "Order" column.

INDOOR UNIT (Cassette type)

When you order parts, please make a photocopy of this page and fill the number of the parts in the "Order" column.

Ref. No.	Description	Part No.	Ord. Q'ty	Ref. No.	Description	Part No.	Ord. Q'ty
		HUM-12UA				HUM-12UA	
64	Capacitor (Fan Motor)	9704305046		468	Special Nut-A (Large)	313005446653	
67	Rubber (Vibration-proof)	9361279001		469	Special Nut-B (Small)	313005446759	
117-3	Special Washer M6	313306391007		470	Separate Wall-B	9359648000	
127	Drain Hose	9359659013		474	Turbo Fan	9359658009	
138	Special Wall-A	9359647003		475	Cushion(Turbo Fan)	9366013006	
146	Evaporator Assy	9373214014		476-1	Special Nut M8	313005360755	
160	Drain Pan	9359651000		476-2	Special Washer	301801185049	
164	Fan Motor Assy-In	9601040019		476-3	Special Washer	9359954002	
184-1	Thermo. Spring-A	313728262708		478	Sensor M. Bracket	9359654001	
185	Rubber Bushing	313005066051		479	Float Switch	313005416154	
187	Clamp No. 1219	313361271706		482	Pump Unit	9359974000	
223	Control Box	9359661016		484	Hanger Metal	9359644002	
234	Thermistor Assy-Room	9703299032		488	Drain Pan Plug	9359653004	
235	Thermistor Assy-Pipe	9703297014		495	Clamp No. 2U46	9352715006	
236	PWB Sub Assy	not available		514	Control Box Cover	9359662006	
237	Controller PCB Assy	9704557605		628	Locking Spacer-B	313005446558	
238	Power PWB Assy	9704561046		629	EMI Filter	0400197119	
240	Remote Assy	9371190037		652-1	Thermistor Holder Pipe	313806262805	
244	Pipe Cover	9359646006		743	Remocon Holder	9305642014	
287	Cap (Power)	9352173011		797	Separate Wall-C	9359649007	
301	Clamp NK-2N	313985355201		798	Pump Hook Bracket	9359650003	
313	Hooking Wire	9359983002		815	Terminal-3P	9900203016	
338	Motor Fixture	9359656005		824-3	Fuse	0600222512	
381	Locking Spacer	313209391506		834	Wire Cover	9359878001	
395	Eva Holder	9373179016		835	Cushion-A (For Pump)	9352211003	
399	Air Duct	9359660002		836	Cushion-B (For Pump)	9356084016	
411	Supporter-A	9359655008		875	Filter PCB Assy	9704561046	
430	Clamp NK-7N	313095365602		964	Flare Nut-A	not available	
457	Drain Pan Support	9359652007		965	Flare Nut-B	9351062019	
462	Top Cover Plate	9359642015		989-1	Cord Clamp-A	9359822011	
464	Body-A	9359643005		989-2	Cord Clamp-B	9359823018	
465	Body-B	9359645009		990	Distributor Assy	9373034049	
467	Drain Port	313005415658		991	Coupling Pipe Assy	not available	

ENINDEL CLIMA

GRILLE ASSY

Ref. No.	Description	Part No.	Ord. Q'ty	Ref. No.	Description	Part No.	Ord. Q'ty
93	Filter	9359632009		694	Cam Gear	9359628002	
165	Motor Cover	9359623014		700	Panel	9359619017	
196	Clamp SKB-150	313035356905		705	Louver	9359624011	
226	Motor Gear	9359629009		710	Intake Grille	9370126006	
385	Indicator PCB Assy	9702224011		711-1	Filter Clamp-A	9359634003	
392	Cover-A	9359622017		711-2	Filter Clamp-B	9359635000	
416	Insulation (Panel)-A	9359620006		758	Decoration Plate-A	9360039019	
417	Insulation (Panel)-B	9359621003		763	Receiver Cover	9359630005	
690	Joint-A	9359626008		776	Grille Stopper	9359633013	
691	Joint-B	9359627005		777	Grille Hook	9359761006	
692	Joint Shaft	9359625001		876-2	Step Motor	9360307019	







When you order parts, please make a photocopy of this page and fill the number of the parts in the "Order" column.

OUTDOOR UNIT

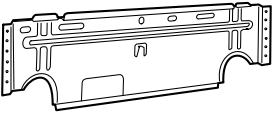



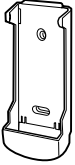
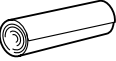

Ref. No.	Description	Part No.	Ord Q'ty	Ref. No.	Description	Part No.	Ord Q'ty
		HOM-20U2A				HOM-20U2A	
2	Fan Cover	9359808015		234	Thermistor Assy	9900123017	
4	Emblem "HIYASU"	9359546009		236	Controller PCB Assy	9702766047	
5	Cabinet-A, Painted	9359797043		328	Compressor Plate Assy	9359830023	
6	Cabinet-C, Painted	9359825029		343-1	Solenoid Coil-A	9900165055	
9	Cabinet-B, Painted	9359824022		343-2	Solenoid Coil-B	9900165062	
12	Base Assy, Painted	9359813019		344-2	4-Way Valve	9900162016	
13-1	3-Way Valve	9372205044		352-1	Expansion Coil-A	9970021015	
14-2	2-Way Valve	9372204054		352-2	Expansion Coil-B	9970021022	
15	Strainer Assy	9366602019		401	Terminal-2P	9701971015	
16	Condenser Assy	9373071013		412-1	Terminal Gasket (comp) (UNIT A)	9351121006	
18-1	Suction Pipe-A Assy	9372997062		412-2	Terminal Gasket (comp) (UNIT B)	9351505011	
18-2	Suction Pipe-B Assy	9373070078		450-2	Discharge Pipe-A Assy	9372997017	
26	Compressor Cover	9364595009		450-3	Discharge Pipe-B Assy	9373070054	
29	Separate Wall	9359805014		477	Bellmouth	9359809012	
32-4	Control Box Metal-D	9361247000		527	Protective Net	9359845010	
32-5	Control Box Metal-E	9361248007		646	NOISE INSULATION B	9355788007	
32-6	Control Box Metal-F	9361249004		653-1	Bolt (Fan Motor Fixing) CUP SCREW	9385089020	
34	Capacitor (Fan Motor)	9704305015		678	Bracket (Thermistor)	9367369010	
37-1	Running Capacitor	9704436122		734	Top Plate, Painted	9359799023	
37-2	Running Capacitor	9704436016		790-1	Belt Heater (UNIT A)	9361140141	
38	Clamp Metal (Capacitor)	9352123009		790-2	Belt Heater (UNIT B)	9361140172	
39	Propeller Fan	9359837015		812	Grip	9352157004	
41-1	Fan Motor Induction-Out (MFB-30DFT)	9600832011		815-1	Terminal-3P	9358660027	
41-2	Fan Motor Induction-Out (MFB-30NTAT)	9601754015		815-3	Terminal-8P	9358660119	
45-3	Motor Bracket-A	9369627002		823-2	Fuse Holder	0500063024	
45-4	Motor Bracket-B	9371439013		824-3	Fuse (3.15A-250V)	0600222512	
45-5	Motor Bracket-C	9369629006		824-4	Fuse (5A-250V)	0600222529	
45-6	Motor Bracket-D	9369630002		825	Expansion Valve	9970020018	
45-7	Motor Bracket center da	9373076018		825-1	Expansion Valve-A Assy	9360821065	
46-1	Compressor Assy (802 354 35B)	9373010036		825-2	Expansion Valve-B Assy	9360822062	
46-2	Compressor Assy (802 100 65B)	9373010012		827	Capillary-A Assy	9360814135	
51	Special Nut (For Comp.)	313199233602		828	Capillary-B Assy	9360815132	
55	Special Nut M8 (For Comp.)	9355091008		829-2	MUFFLER A SUB ASSY	9373022015	
64	Cabinet-Left, Painted	9359840046		829-5	2 WAY VALVE PIPE A1	9372996362	
84	Valve Cover	9359834014		830-2	MUFFLER B SUB ASSY	9373023012	
85	Valve Plate Assy, Painted	9361251021		830-5	2 WAY VALVE PIPE B1	9372996386	
107-1	Rubber Seat (For Comp.) A (UNIT A)	9351813017		838-1	INLET PIPE A ASSY	9360832047	
107-2	Rubber Seat (For Comp.) A (UNIT B)	9351507015		838-2	DISCHARGE PIPE A3	9372996041	
109-1	Terminal Cover (Comp.) (UNIT A)	9351120009		840-1	INLET PIPE B ASSY	9360833051	
109-2	Terminal Cover (Comp.) (UNIT B)	9302419008		840-2	DISCHARGE PIPE B3	9372996089	
117-3	Hex. Nut	301721180114		982-1	Cord Clamp	9356857009	
149	Water Seal Plate	9359841029		982-2	Cord Clamp-B	9356858006	
165	Surge Absorber	9702968014		990-1	SUCTION PIPE A3	9372996423	
184-1	Thermo. Spring-A	313728262708		990-2	SUCTION PIPE A4	9372996430	
185	Rubber Bushing	313005066051		991-1	SUCTION PIPE B3	9372996461	
187	Clamp No. 1219	313361271706		991-2	SUCTION PIPE B4	9372996478	
210	Main Relay	9356781007					
230-1	Ocr Assy (MRA99908-9201) (UNIT A)	9312899005					
230-2	Ocr Assy (MRA99170-9201) (UNIT B)	9309128002					
233	Power Transformer	9701156016					

STANDARD ACCESSORIES

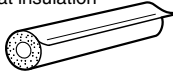

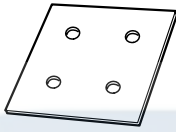

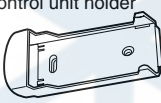
INDOOR UNIT ACCESSORIES (Wall Mounted type)

Name and Shape	Q'ty	Part No.
Wall hook bracket 	1	9304358008
Wall cap-B 	1	313714296205
Remote control unit 	1	9307113055 (AR-DB5)
Battery (penlight) 	1 set	0600185534
Remote control unit holder 	1	9305642014
Cloth tape 	1	9308117007
Tapping screw (big) (ø4 x 25) 	8	0700076046
Tapping screw (small) (ø3 x 12) 	2	0700019036

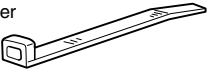

INDOOR UNIT ACCESSORIES (Cassette type)

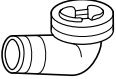
Name and Shape	Application	Part No.
Coupler heat insulation 	For indoor side pipe joint	9350716029 9352766015
Special nut A (large flange) 	For installing indoor unit	313005446653
Special nut B (small flange) 	For installing indoor unit	313005446759
Template 	For ceiling hole cutting	9360256003
Remote control unit 	Use for air conditioner operation	9371190037 (Cooling & Heating model)
Battery (penlight) 	For remote control unit	0600185534
Remote control unit holder 	For mounting the remote control unit	9305642014
Tapping screw (ø 3 x 12) 	For remote control unit holder installation	301141533125

OUTDOOR UNIT ACCESSORIES

Name and Shape	Q'ty	Part No.
Binder 	2	312300787605
Putty 	1	303020200114
Hexagon wrench 	1	9351228019
Drain pipe 	1	9303029015
Drain cap 	2	313166024302

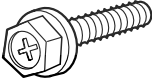
GRILLE ASSY ACCESSORIES

Name and Shape	Application	Part No.
Bolt 	For opening the refrigerant valve on the outdoor unit	0700139116
Washer 	For mounting grille	301801155020
Blower cover insulation 	For discharged air	9360047007

