



**HIGH POWER MULTI
AIR CONDITIONER
WALL MOUNTED type**

SERVICE MANUAL

Models

Indoor unit

HSM-9UA

HSM-9UA

Outdoor unit

HOM-19U2A

HOM-19U2B



ENINDEL CLIMA

CONTENTS

SPECIFICATIONS.....	1
OUTLINE AND DIMENSIONS.....	2
REFRIGERANT SYSTEM DIAGRAM.....	3
ERROR DISPLAY.....	4
CIRCUIT DIAGRAM.....	5
INDOOR PCB CIRCUIT DIAGRAM.....	6
OUTDOOR PCB CIRCUIT DIAGRAM ...	7
DISASSEMBLY ILLUSTRATION.....	8
PARTS LIST.....	16

SPECIFICATIONS

TYPE	COOL & HEAT			
INDOOR UNIT	HSM-9UA	HSM-9UA x 2	HSM-9UA	HSM-9UA x 2
OUTDOOR UNIT	HOM-19U2A	HOM-19U2A	HOM-19U2B	HOM-19U2B
COOLING CAPACITY (kW)	2.70	5.40	2.70	5.40
HEATING CAPACITY	3.30	6.60	3.25	6.50

ELECTRICAL DATA

POWER SOURCE (V)		230	230	230	230
FREQUENCY (Hz)		50	50	50	50
RUNNING CURRENT (A)	COOLING	4.6	8.7	4.6	8.7
	HEATING	5.1	9.1	5.1	9.1
INPUT WATTS (kW)	COOLING	1.01	1.92	1.01	1.92
	HEATING	1.14	2.03	1.14	2.02
E.E.R. (kW/kW)	COOLING	2.67	2.81	2.67	2.81
	HEATING	2.89	3.21	2.85	3.22
MOISTURE REMOVAL (ℓ/hr)		1.2	2.4	1.2	2.4
AIR CIRCULATION-Hi (m³/hr)		470	470 x 2	470	470 x 2

COMPRESSOR

TYPE	Hermetic type, Permanent split condenser, 2 pole, Single phase, Induction motor, Rotary		
POWER SOURCE	230V - 50Hz		
DISCRIMINATION	802 141 65B	GK 120 PAB	
REFRIGERANT R410A (g)	900 x 2		

FAN MOTOR

POWER SOURCE (V)	230	
INDOOR UNIT	HI-SPEED (r.p.m.)	1,200 / 1,200
	MED-SPEED (r.p.m.)	1,100 / 1,100
	LO-SPEED (r.p.m.)	1,000 / 1,000
	QUIET (r.p.m.)	940 / 940
OUTDOOR UNIT (r.p.m.)	720	

DIMENSIONS

INDOOR UNIT	H x W x D (mm)	257 x 808 x 187
OUTDOOR UNIT	H x W x D (mm)	700 x 900 x 350

WEIGHT

INDOOR UNIT	GROSS / NET (kg)	10 / 8	
OUTDOOR UNIT	GROSS / NET (kg)	74 / 68	76 / 70

OUTLINE AND DIMENSIONS

INDOOR UNIT

(Unit : mm)

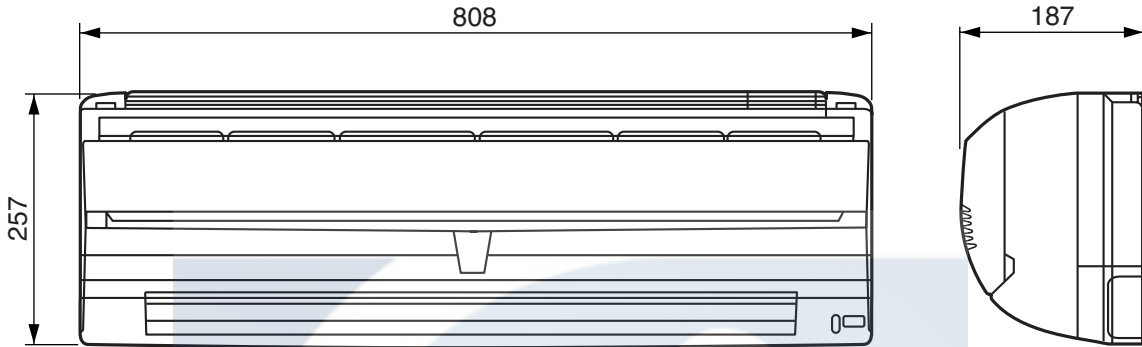

OUTDOOR UNIT

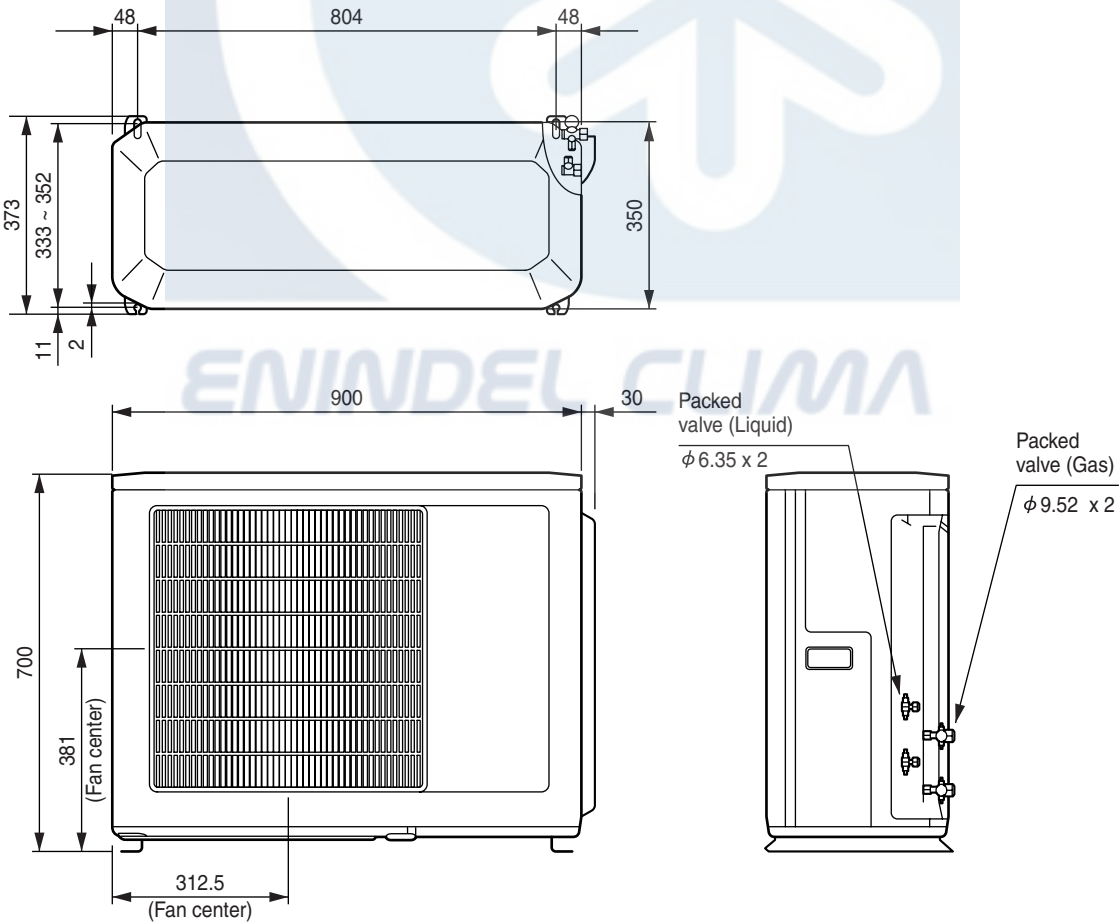

REFRIGERANT SYSTEM DIAGRAM

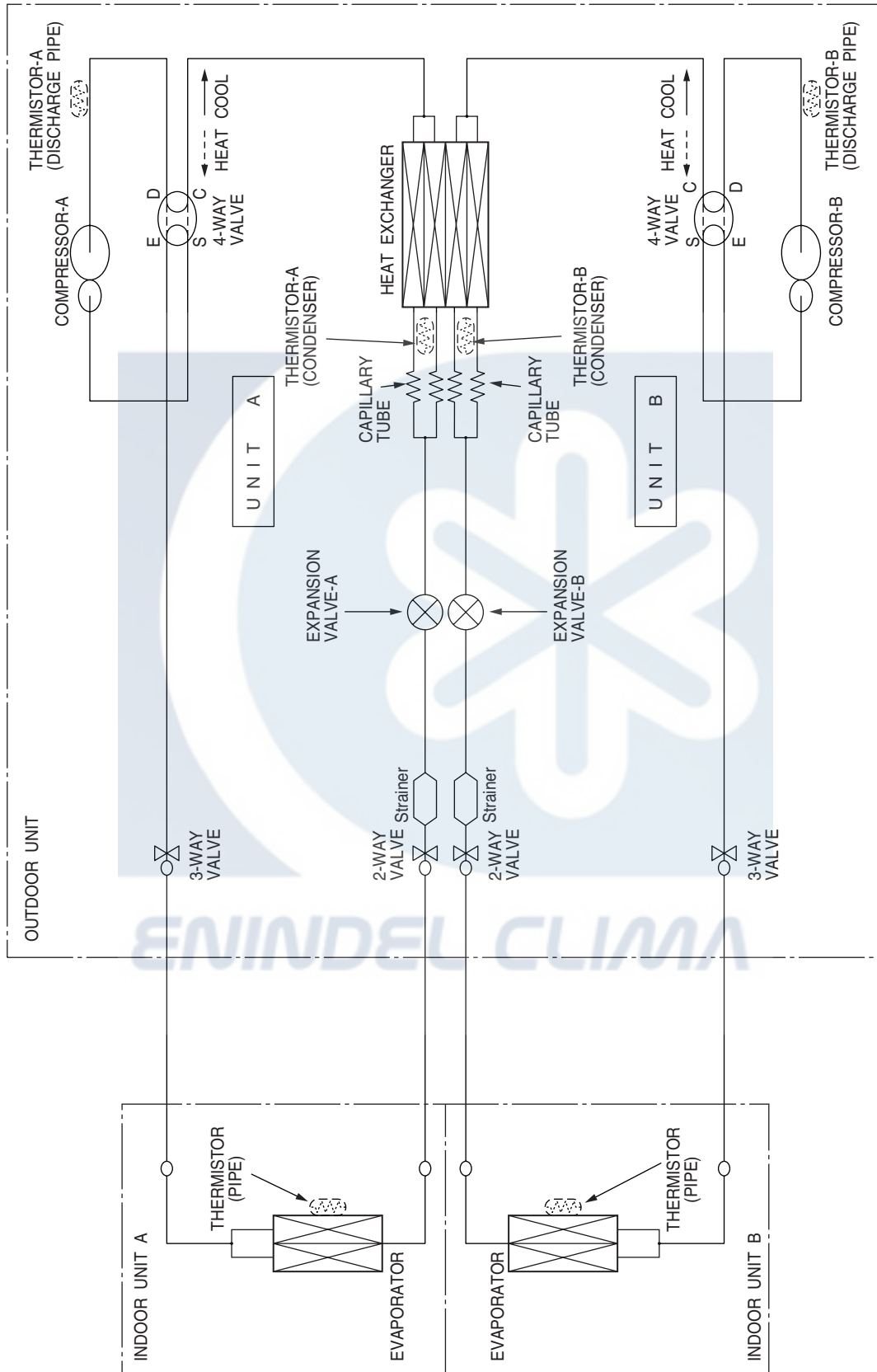

CIRCUIT DIAGRAM

INDOOR UNIT

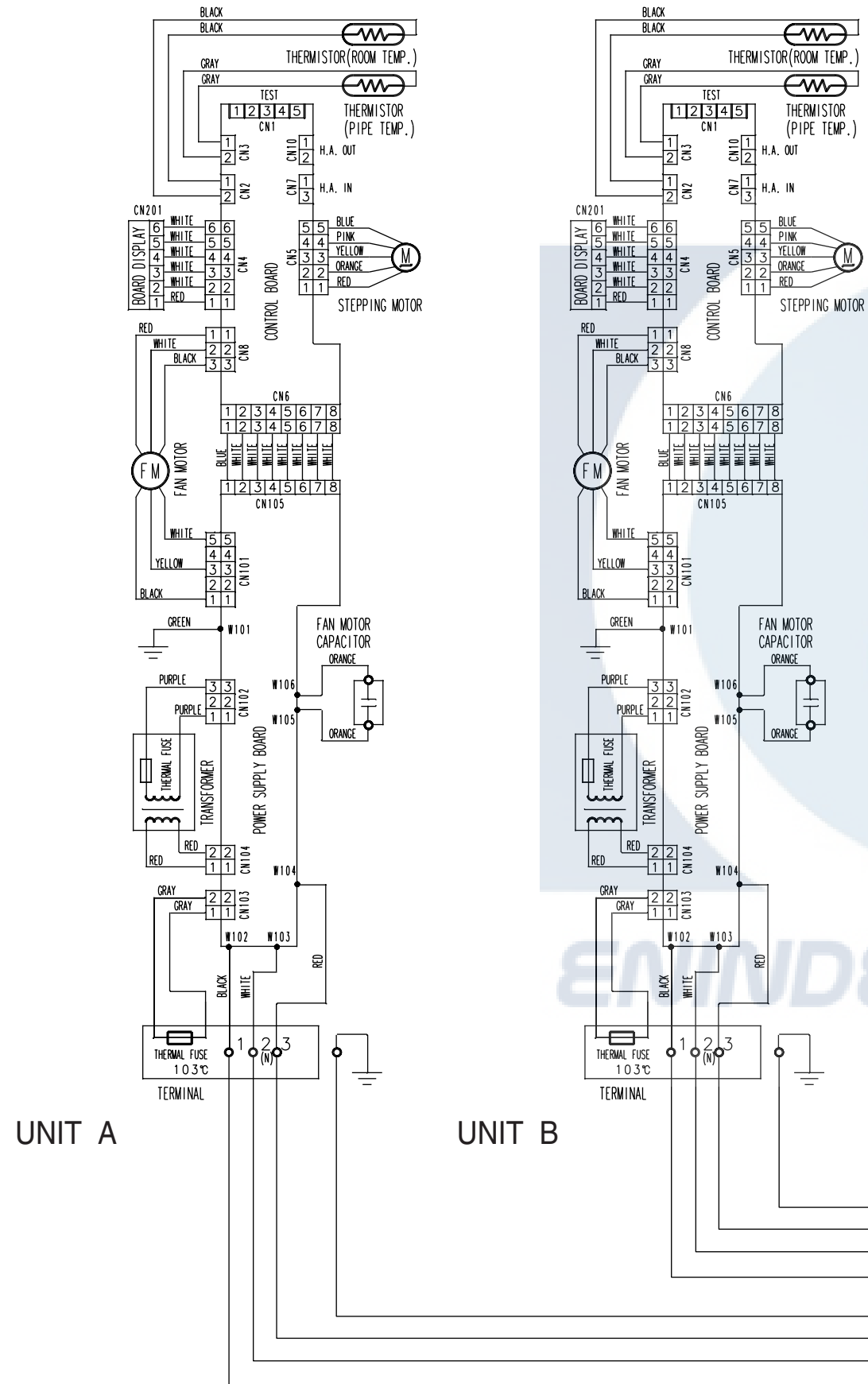

OUTDOOR UNIT

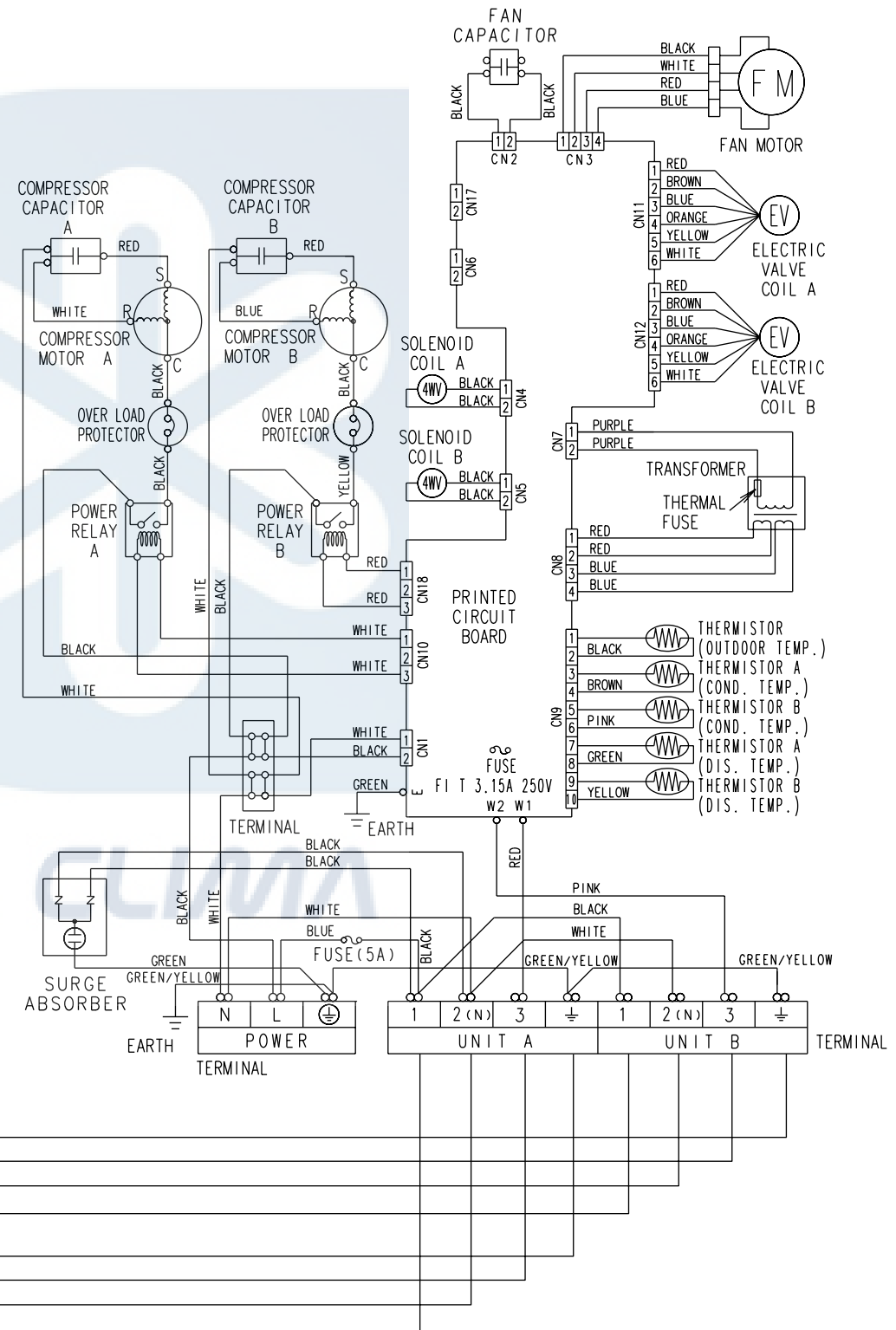

INDOOR PCB CIRCUIT DIAGRAM

Model : HSM-9UA

Jumper wire configurations

Switch	Function	ON /Linked	OFF /Open
JM1	Heating compensation	+4	0
JM2	Cooling (Dry) compensation	0	-2
JM4	Custom code	A	B

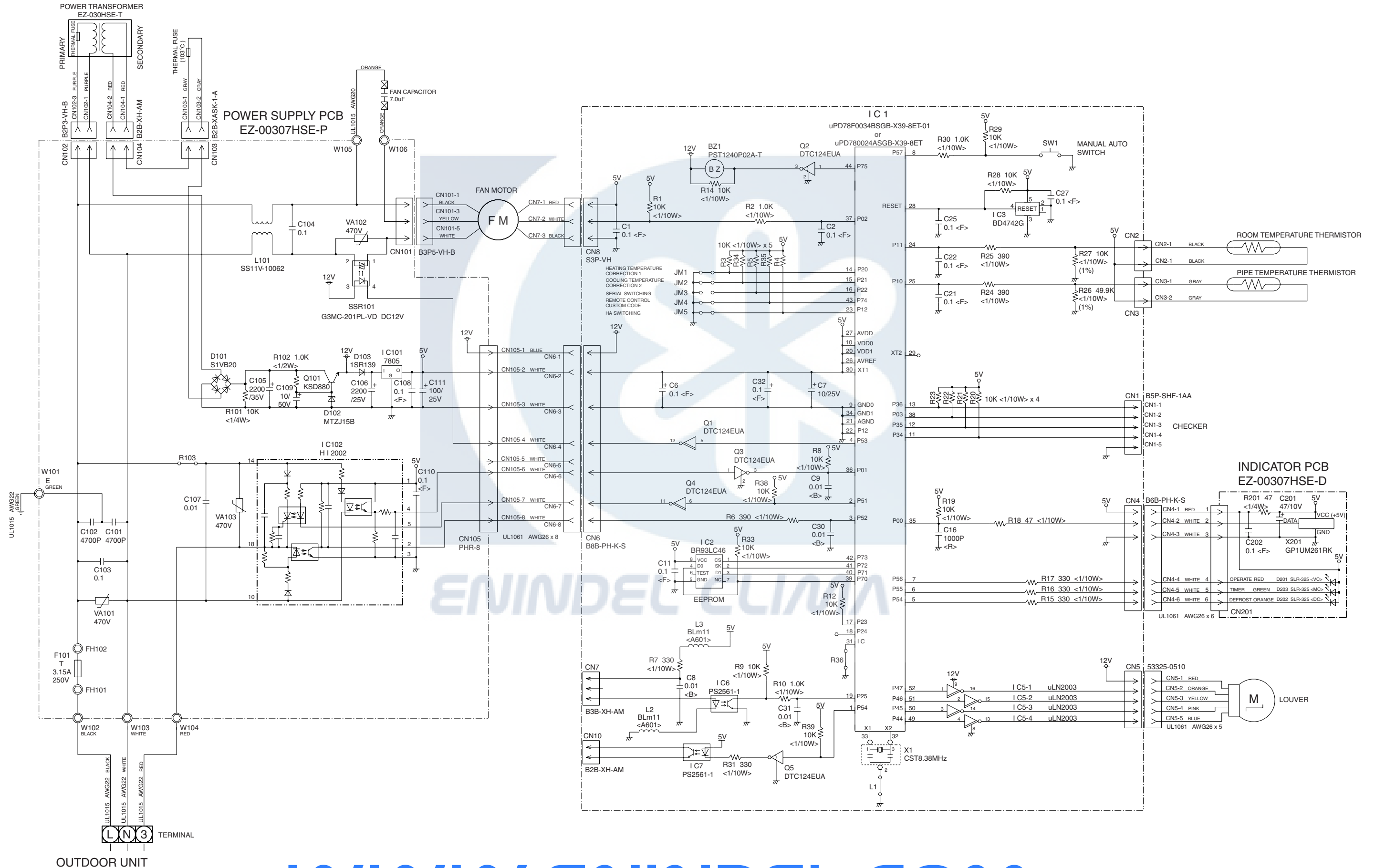

OUTDOOR PCB CIRCUIT DIAGRAM

Models: HOM-19U2A
HOM-19U2B

CONTROLLER PCB ASSEMBLY (MAIN PCB)
EZ-003KHUE-C

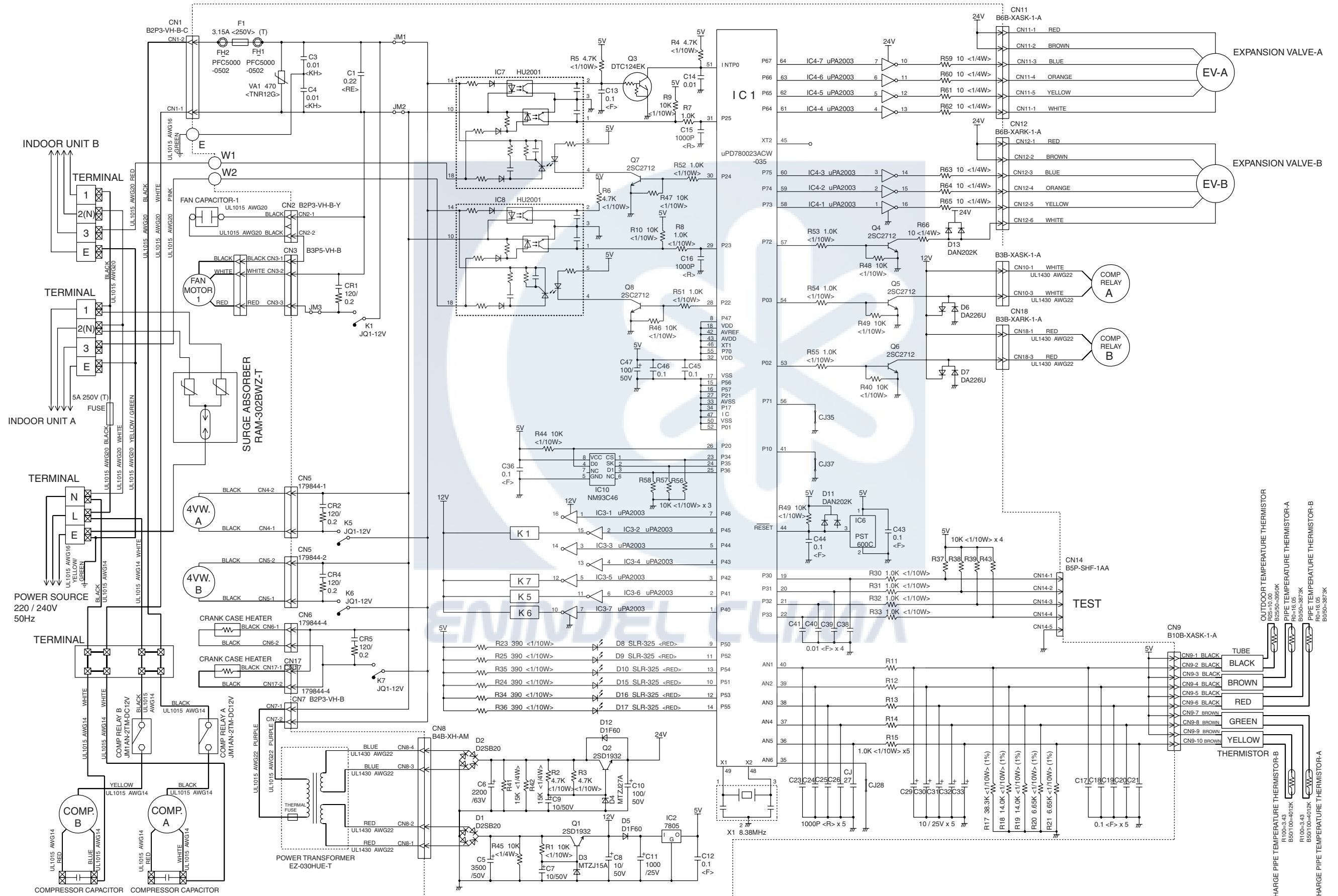

DISASSEMBLY ILLUSTRATION

Model : HSM-9UA

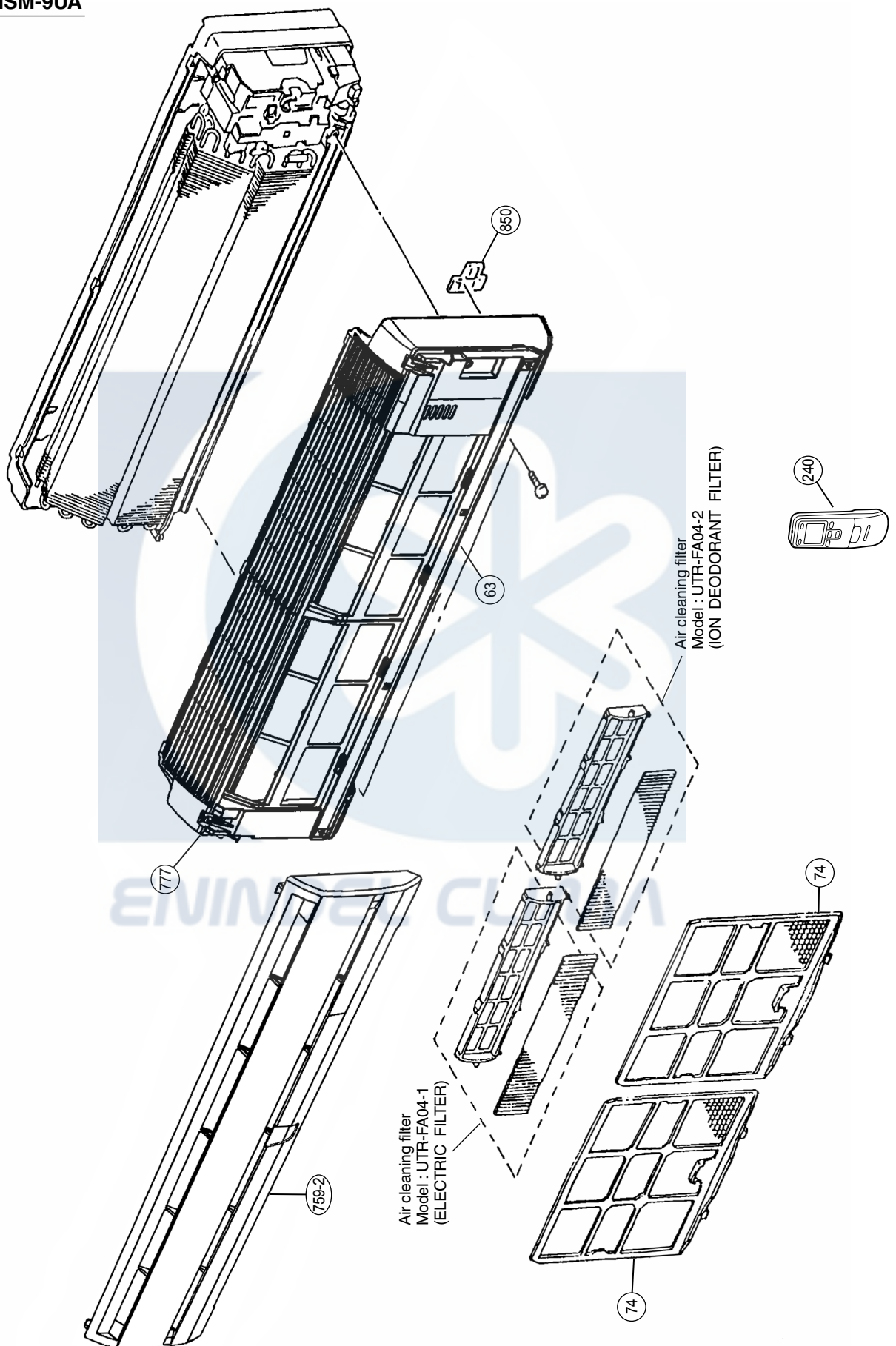

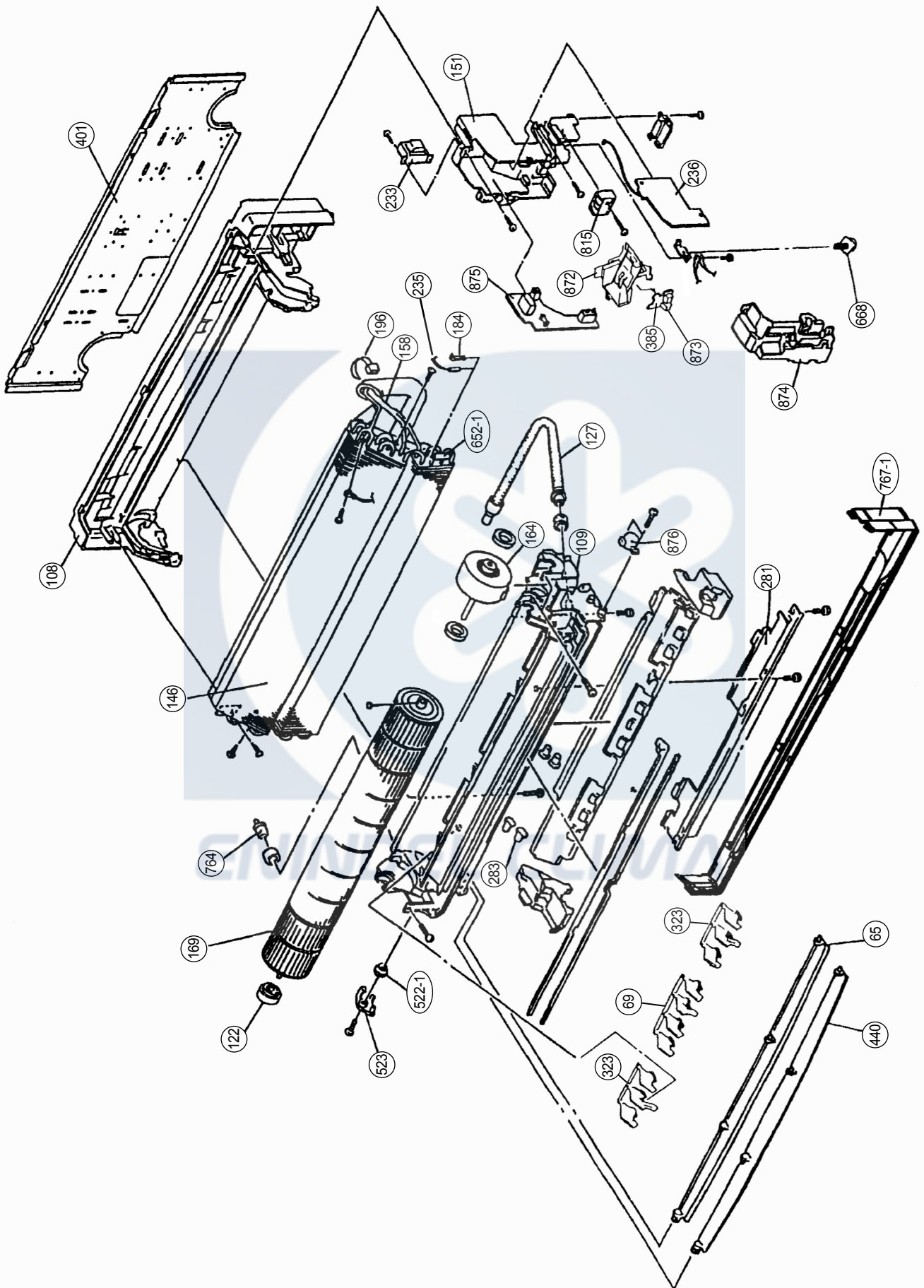

Models : HOM-19U2A
HOM-19U2B

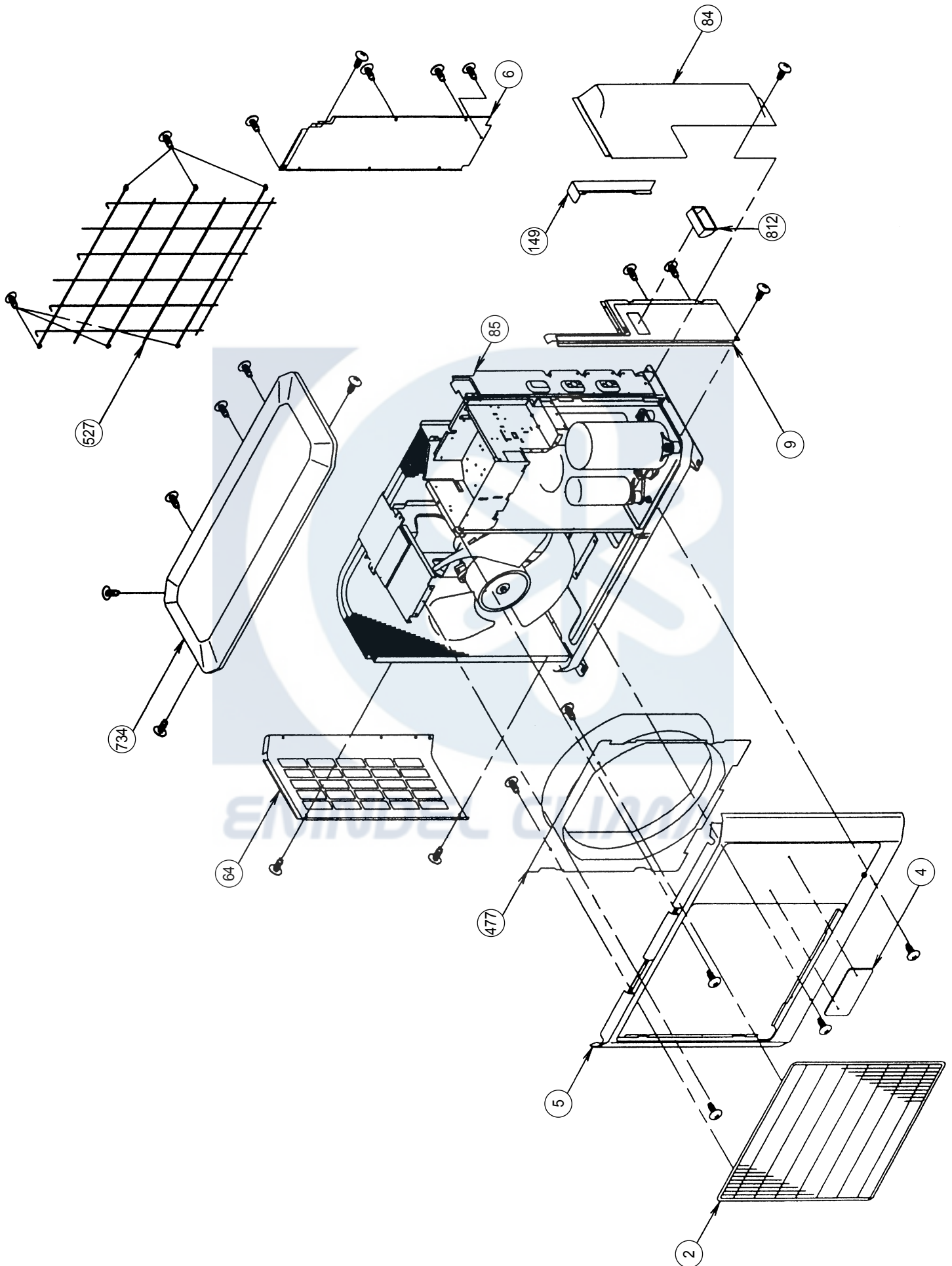

Models : HOM-19U2A
HOM-19U2B

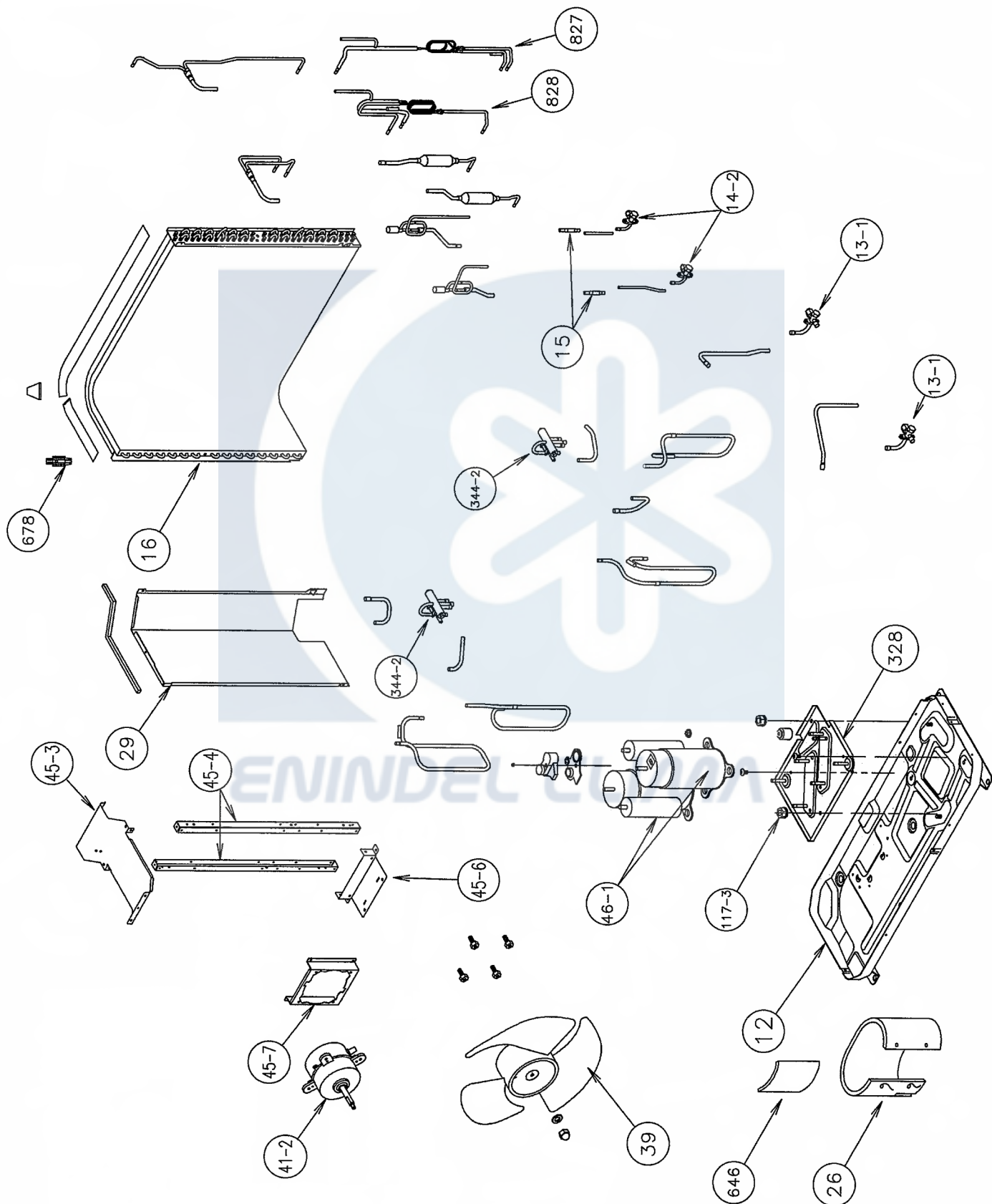

Models : HOM-19U2A
HOM-19U2B

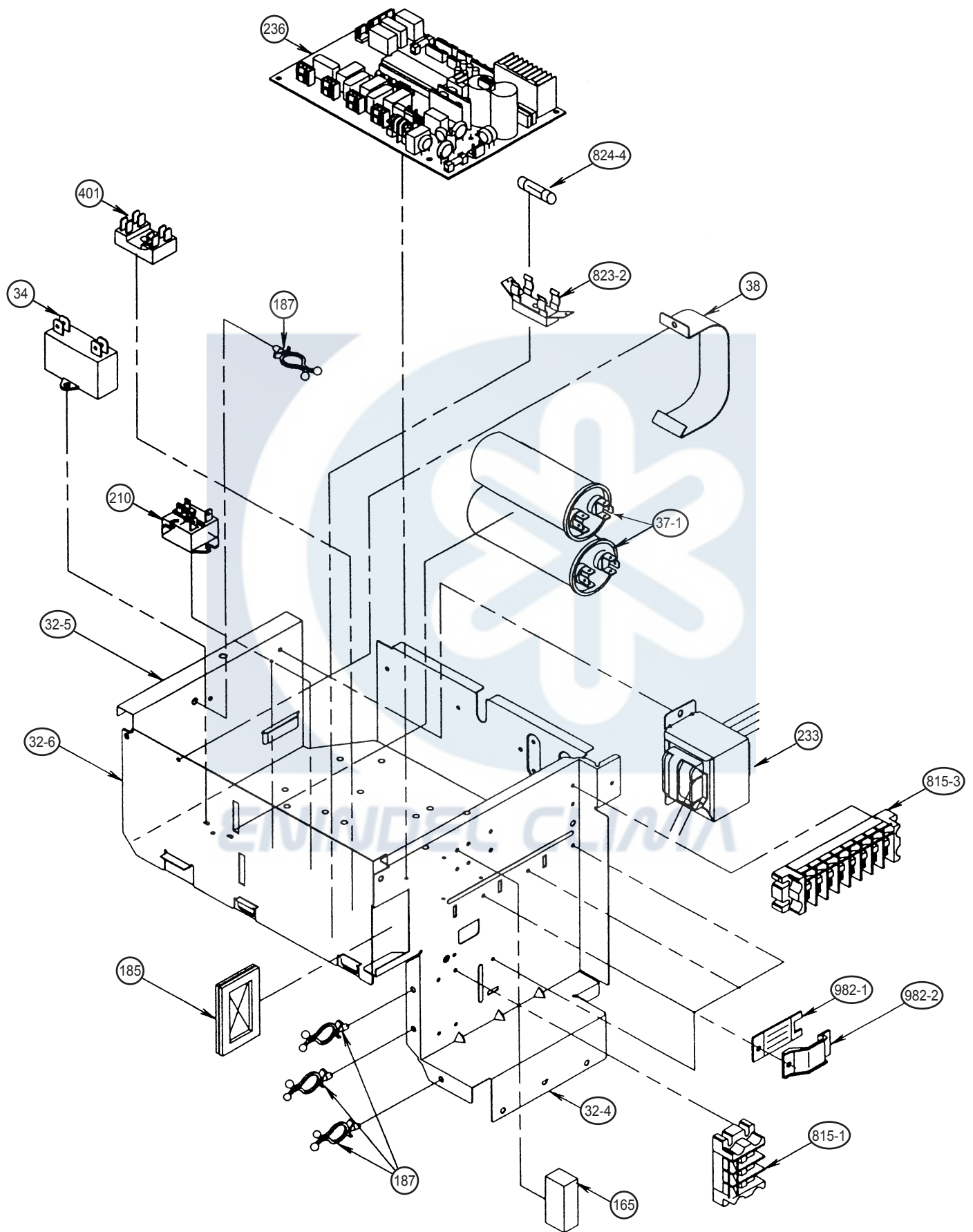

Models : HOM-19U2A
HOM-19U2B

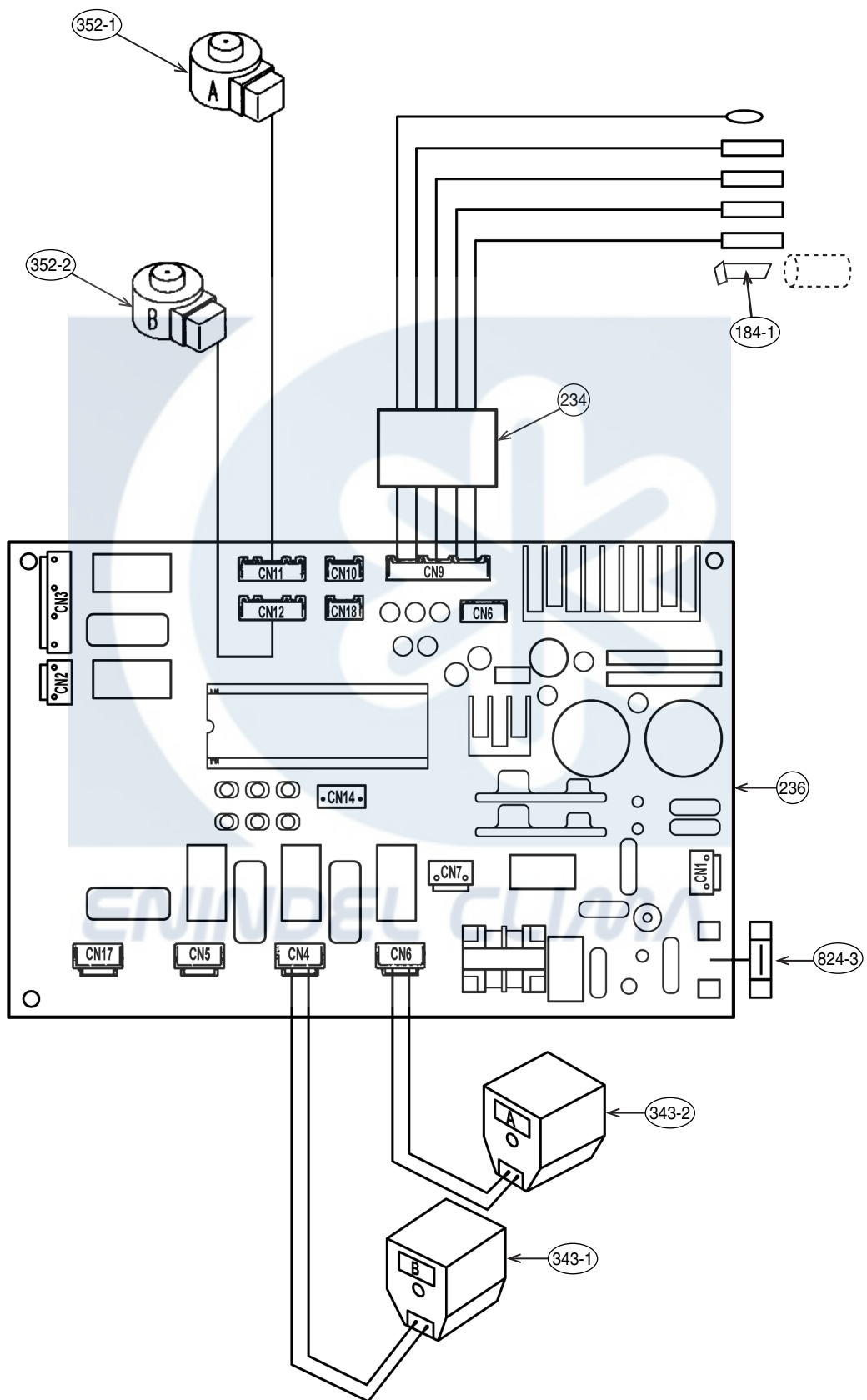

Model : HOM-19U2A
(802-141-65B)

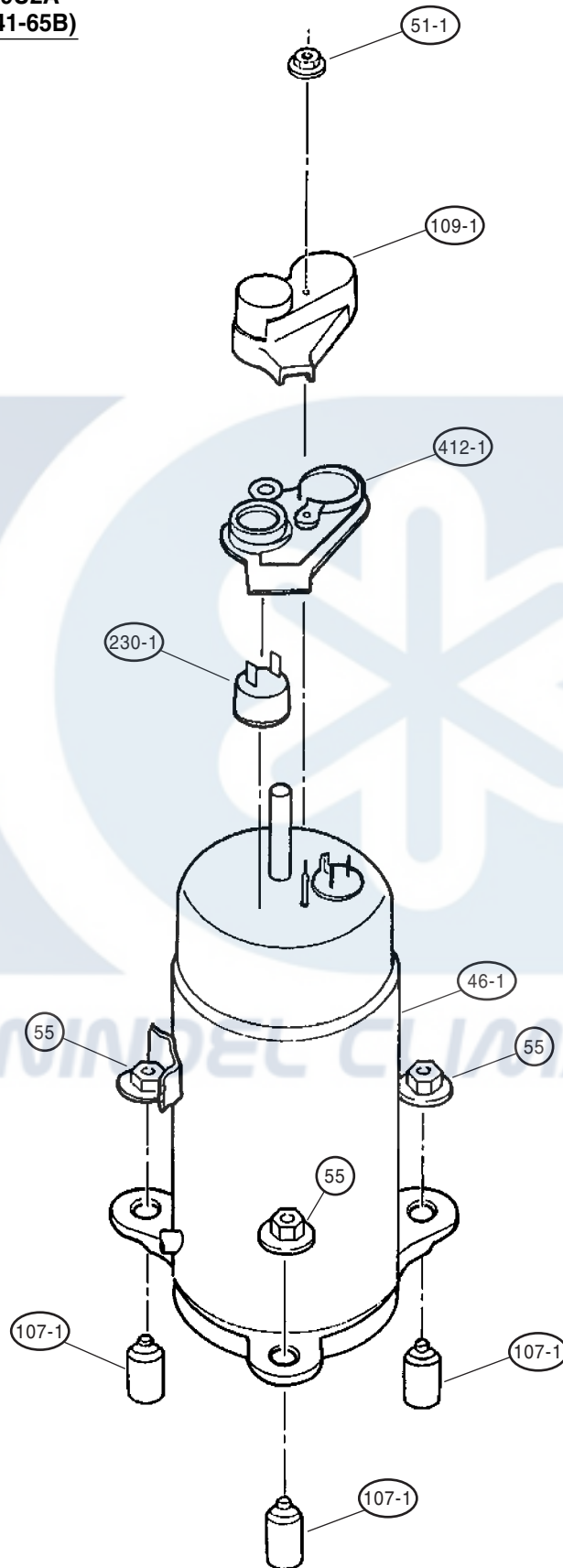

Model : HOM-19U2B
(GK120PAB)

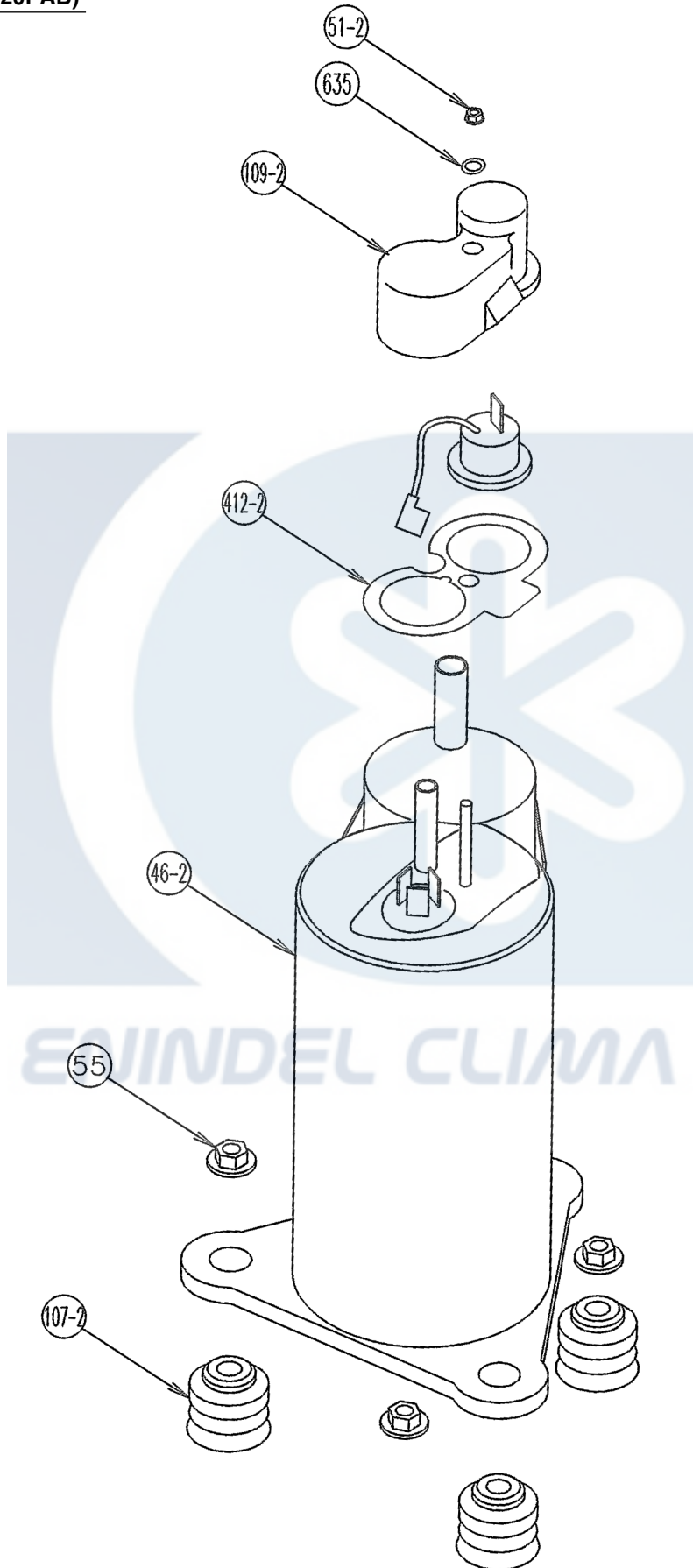

PARTS LIST

INDOOR UNIT

Ref. No.	Description	Part No.	Ord. Q'ty
		HSM-9UA	
63	Front Panel Assy	9312172184	
65	Flow Control Panel-Z	9306058043	
69	Louver-A	9306055028	
74	Filter	9305444014	
108	Base	9309755062	
109	Casing Assy	9312173020	
122	Shaft Holder-B	9303066010	
127	Drain Hose Assy	9305550029	
146	Evaporator Assy	9373044017	
151	Control Box	9330007017	
158	Connecting Pipe Assy	9306416010	
164	Fan Motor Assy-IN	9601844013	
169	Cross-Flow Fan Assy	9307836015	
184	Thermistor Spring	313728262708	
196	Clamp SKB-150	313035356905	
233	Power Transformer	9900028015	
235	Thermistor Assy-Pipe	9702039059	
236	Controller PCB Assy	9705289055	
240	Remote Control Unit	9371190211	
281	Clamp Metal(Pipe)	9306063009	
283	Bushing-A	9303529010	
323	Louver-B	9306056025	
385	Indicator PCB Assy	9705296015	
401	Wall Hook Bracket	9304358008	
440	Flow Control Panel-U	9306057046	
522-1	Gear-A	9306062002	
523	Gear Bracket	9306407001	
652-1	Thermistor Holder Pipe	313714262805	
668	Screw w/Washer	313681304205	
759-2	Intake Grille-B	9330002036	
764	Drain Cap Assy	9304150008	
767-1	Bottom Cover	9330004016	
777	Clamper(Grille)	9306755010	
815	Terminal	9900040055	
850	Window (Receiver)	9330003019	
872	Indicator Case	9330009011	
873	Lamp Cover	9330014015	
874	Control Box Cover	9330008014	
875	Power Supply PCB Assy	9705294011	
876	Step Motor	9900139018	







OUTDOOR UNIT

Ref. No.	Description	Part No.		Ord. Q'ty	Ref. No.	Description	Part No.		Ord. Q'ty
		HOM-19U2A	HOM-19U2B				HOM-19U2A	HOM-19U2B	
2	Fan Cover	9371187013	9371187013		184-1	Thermo. Spring-A	313728262708	313728262708	
4	Emblem	9359546009	9359546009		185	Rubber Bushing	313005066051	313005066051	
5	Cabinet-A, Painted	9359797043	9359797043		187	Clamp No. 1219	313361271706	313361271706	
6	Cabinet-C, Painted	9359825029	9359825029		210	Main Relay	9356781007	9356781007	
9	Cabinet-B, Painted	9359824022	9359824022		230-1	Ocr assy (MRA99134-9201)	9311143000	----	
12	Base Assy, Painted	9359813019	9359813019		233	Power Transformer	9701156016	9701156016	
13-1	3-Way Valve	9372205044	9372205044		234	Thermistor Assy	9900123017	9900123017	
14-2	2-Way Valve	9372204054	9372204054		236	Controller PCB Assy	9702766030	9702766030	
15	Strainer Assy	9366602019	9366602019		328	Compressor Plate Assy	9359830030	9359830030	
16	Condenser Assy	9372662014	9372662014		343-1	Solenoid Coil-A	9900165055	9900165055	
26	Compressor Cover A	9364595009	9364595009		343-2	Solenoid Coil-B	9900165062	9900165062	
29	Separate Wall	9359805014	9359805014		344-2	4-Way Valve	9900162016	9900162016	
32-4	Control Box Metal-D	9361247000	9361247000		352-1	Expansion Coil-A	9970021015	9970021015	
32-5	Control Box Metal-E	9361248007	9361248007		352-2	Expansion Coil-B	9970021022	9970021022	
32-6	Control Box Metal-F	9361249004	9361249004		401	Terminal-2P	9701971015	9701971015	
34	Capacitor (Fan Motor)	9703306051	9703306051		412	Terminal Gasket (For Comp.)	9351505011	9351505011	
37-1	Running Capacitor	9704436139	9704436139		412-2	Attachment (Cover Gasket)	----	9362004008	
38	Clamp Metal (Capacitor)	9352123009	9352123009		477	Bellmouth	9359809012	9359809012	
39	Propeller Fan	9359837015	9359837015		527	Protective Net	9359845010	9359845010	
41-2	Fan Motor Induction-Out (MFB-30NTAT)	9601754015	9601754015		635	Attachment Washer (Gasket)	----	9359428015	
45-3	Motor Bracket-A	9369627002	9369627002		646	NOISE INSULATION B	9355788007	9355788007	
45-4	Motor Bracket-B	9371439013	9371439013		678	Bracket (Thermistor)	9367369010	9367369010	
45-6	Motor Bracket-D	9369630002	9369630002		734	Top Plate, Painted	9359799023	9359799023	
45-7	Motor Bracket center da	9373076018	9373076018		812	Grip	9352157004	9352157004	
46-1	Compressor Assy (802-141-65B)	9373010029	9373010029		815-1	Terminal-3P	9358660027	9358660027	
46-2	Compressor (GK-120-PAB)	----	9373548027		815-3	Terminal-8P	9358660119	9358660119	
51-1	Special Nut (For Comp.)	313199233602	----		823-2	Fuse Holder	0500063024	0500063024	
51-2	Attachment (Nut)	----	9359430018		824-3	Fuse (3.15A-250V)	0600285234	0600285234	
55	Special Nut M8 (For Comp.)	9355091008	9355091008		827	Capillary-A Assy	9360814128	9360814128	
64	Cabinet-Left, Painted	9359840046	9359840046		828	Capillary-B Assy	9360815132	9360815132	
84	Valve Cover	9359834014	9359834014		982-1	Cord Clamp	9356857009	9356857009	
85	Valve Plate Assy, Painted	9361251021	9361251021		982-2	Cord Clamp-B	9356858006	9356858006	
107-1	Rubber Seat (For Comp.)	9351507015	----						
107-2	Attachment (Rubber Seat-A)	----	9359425014						
109-1	Terminal Cover (For Comp.)	9302419008	----						
109-2	Terminal Cover (For Comp.)	----	9363263008						
117-3	Hex. Nut	301721180114	301721180114						
149	Water Seal Plate	9359841029	9359841029						
165	Surge Absorber	9702968014	9702968014						

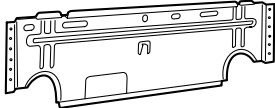
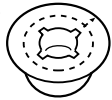
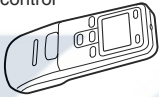

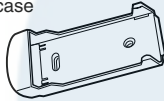

When you order parts, please make a photocopy of this page and fill the number of the parts in the "Order" column.

STANDARD ACCESSORIES

INDOOR UNIT ACCESSORIES

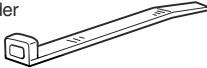
Name and Shape	Q'ty	Part No.
Wall hook bracket 	1	9304358008
Wall cap-B 	1	313714296205
Remote control unit 	1	9307979057 (AR-DB5)
Battery (penlight) 	1 set	0600185534
Remote control unit holder case 	1	9305642014
Cloth tape 	1	9308117007
Tapping screw (big) (ϕ 4 x 25) 	8	0700076046
Tapping screw (small) (ϕ 3 x 12) 	2	0700019036

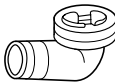
OUTDOOR UNIT ACCESSORIES

Name and Shape	Q'ty	Part No.
Binder 	2	312300787605
Putty 	1	303020200114
Hexagon wrench 	1	9351228019
Drain pipe 	1	9303029015
Drain cap 	2	313166024302

