

# Refrigerant R410A

# SPLIT TYPE ROOM AIR CONDITIONER INSTALLATION INSTRUCTION SHEET

(PART NO. 9373472018)

<b>WARNING</b>	This mark indicates procedures which, if improperly performed, might lead to the death or serious injury of the user.
<b>CAUTION</b>	This mark indicates procedures which, if improperly performed, might possibly result in personal harm to the user, or damage to property.

**This air conditioner uses new refrigerant HFC (R410A).**  
The basic installation work procedures are the same as conventional refrigerant (R22) models. However, pay careful attention to the following points:

- Since the working pressure is 1.6 times higher than that of conventional refrigerant (R22) models, some of the piping and installation and service tools are special. (See the table below.) Especially, when replacing a conventional refrigerant (R22) model with a new refrigerant R410A model, always replace the conventional piping and flare nuts with the R410A piping and flare nuts.
- Models that use refrigerant R410A have a different charging port thread diameter to prevent erroneous charging with conventional refrigerant (R22) and for safety. Therefore, check beforehand. [The charging port thread diameter for R410A is 1/2 UNF 20 threads per inch.]
- Be more careful that foreign matter (oil, water, etc.) does not enter the piping than with refrigerant (R22) models. Also, when storing the piping, securely seal the openings by pinching, taping, etc.
- When charging the refrigerant, take into account the slight change in the composition of the gas and liquid phases, and always charge from the liquid phase side whose composition is stable.

## Special tools for R410A

Tool name	Contents of change
Gauge manifold	Pressure is high and cannot be measured with a conventional gauge. To prevent erroneous mixing of other refrigerants, the diameter of each port has been changed. It is recommended the gauge with seals -0.1 to 5.3 MPa (-76 cmHg to 53 kgf/cm <sup>2</sup> ) for high pressure. -0.1 to 3.8 MPa (-76 cmHg to 38 kgf/cm <sup>2</sup> ) for low pressure.
Charge hose	To increase pressure resistance, the hose material and base size were changed.
Vacuum pump	A conventional vacuum pump can be used by installing a vacuum pump adapter.
Gas leakage detector	Special gas leakage detector for HFC refrigerant R410A.

## Copper pipes

It is necessary to use seamless copper pipes and it is desirable that the amount of residual oil is less than 40 mg/10m. Do not use copper pipes having a collapsed, deformed or discolored portion (especially on the interior surface). Otherwise, the expansion valve or capillary tube may become blocked with contaminants. As an air conditioner using R410A incurs pressure higher than when using R22, it is necessary to choose adequate materials. Thicknesses of copper pipes used with R410A are as shown in Table 1. Never use copper pipes thinner than 0.8 mm (Normal diameter is 1/4 in. and 1/2 in.), even when it is available on the market.

Table 1 Thicknesses of Annealed Copper Pipes

Nominal diameter (inch)	Outer diameter (mm)	Thickness (mm)	
		R410A	[ref.] R22
1/4	6.35	0.80	0.80
1/2	12.7	0.80	0.80

## For authorized service personnel only.

- WARNING**
- For the room air conditioner to operate satisfactorily, install it as outlined in this installation instruction sheet.
  - Connect the indoor unit and outdoor unit with the room air conditioner piping and cords available standards parts. This installation instruction sheet describes the correct connections using the installation set available from our standard parts.
  - Installation work must be performed in accordance with national wiring standards by authorized personnel only.
  - If refrigerant leaks while work is being carried out, ventilate the area. If the refrigerant comes in contact with a flame, it produces a toxic gas.
  - Do not use an extension cord.
  - Do not turn on the power until all installation work is complete.
- Be careful not to scratch the room air conditioner when handling it.  
• After installation, explain correct operation to the customer, using the operating manual.  
• Let the customer keep this installation instruction sheet because it is used when the air conditioner is serviced or moved.

## SELECTING THE MOUNTING POSITION

**WARNING**  
Install at a place that can withstand the weight of the indoor and outdoor units and install positively so that the units will not topple or fall.

**CAUTION**  
(1) Do not install where there is the danger of combustible gas leakage.  
(2) Do not install near heat sources.  
(3) If children under 10 years old may approach the unit, take preventive measures so that they cannot reach the unit.

Decide the mounting position with the customer as follows:

### 1. INDOOR UNIT

- Install the indoor unit level on a strong wall which is not subject to vibration.
- The inlet and outlet ports should not be obstructed: the air should be able to blow all over the room.
- Install near a power supply (exclusive circuit). (Place with in reach of the plug.)
- Do not install the unit where it will be exposed to direct sunlight.
- Install the unit where connection to the outdoor unit is easy.
- Install the unit where the drain pipe can be easily installed.
- Take servicing, etc. into consideration and leave the spaces shown in (Fig. 1). Also install the unit where the filter can be removed.

Fig. 1

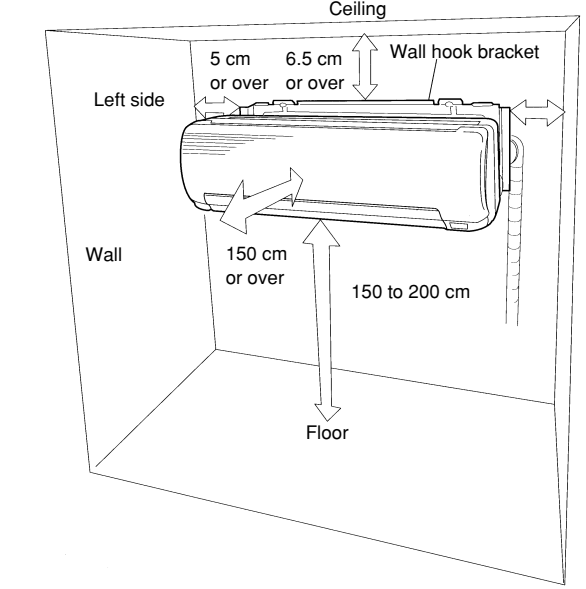

### 2. OUTDOOR UNIT

- If possible, do not install the unit where it will be exposed to direct sunlight. (If necessary, install a blind that does not interfere with the air flow.)
- Do not install the unit where a strong wind blows or where it is very dusty.
- Do not install the unit where people pass.
- Take your neighbors into consideration so that they are not disturbed by air blowing into their windows or by noise.
- Provide the space shown in Fig. 2 so that the air flow is not blocked. Also for efficient operation, leave open three of the four directions front, rear, and both sides.

Fig. 2

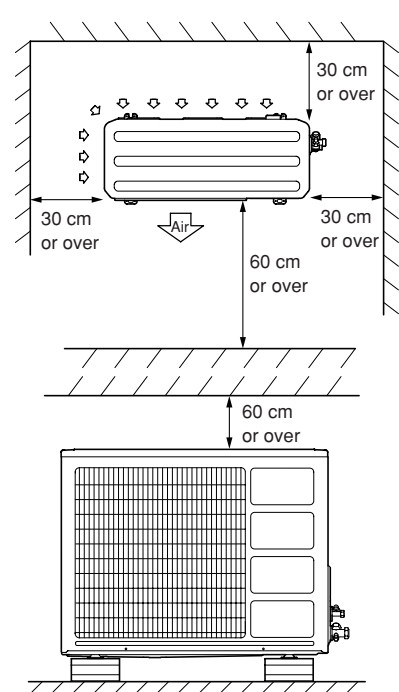

## STANDARD ACCESSORIES

The following installation accessories are supplied. Use them as required.

### INDOOR UNIT ACCESSORIES

Name and Shape	Qty	Use
Wall hook bracket	1	For indoor unit installation
Wall cap	1	For through hole connection pipe protection
Remote controller	1	
Battery (penlight)	2	For remote controller
Cable mark	1	Stick on both ends of connection cord (to prevent incorrect wiring) [Heat & Cool model (Reverse cycle) only]
Tapping screw (big) (ø4 x 20)	8	For wall hook bracket installation
Tapping screw (small) (ø3 x 12)	2	For remote controller holder installation
Flange screw (ø4 x 10)	2	For indoor unit installation
Spacer	1	For indoor unit installation
Remote controller holder	1	
Cloth tape	1	For indoor unit installation
Seal A	1	For indoor unit installation

## OUTDOOR UNIT ACCESSORIES

Drain pipe	1	For outdoor unit drain piping work [Heat & Cool model (Reverse cycle) only]
Drain cap	1	

This installation instruction sheet refers to following parts which are included in the optionally available installation set.

Tool name	Oty
Connection pipe assembly	1
Connection cord (3-conductor)	1
Connection cord (2-conductor) [Heat & Cool model (Reverse cycle) only]	1
Wall pipe	1
Decorative tape	1 roll
Vinyl tape	1 set
Wall cap	1 set
Saddle	1 set
Drain hose	1
Wood screws	1 set
Sealant	1 set

## INSTALLATION PROCEDURE

### 1 INDOOR UNIT INSTALLATION

The piping can be connected in the six directions indicated by ①, ②, ③, ④ and ⑤ in Fig. 4.

Fig. 4

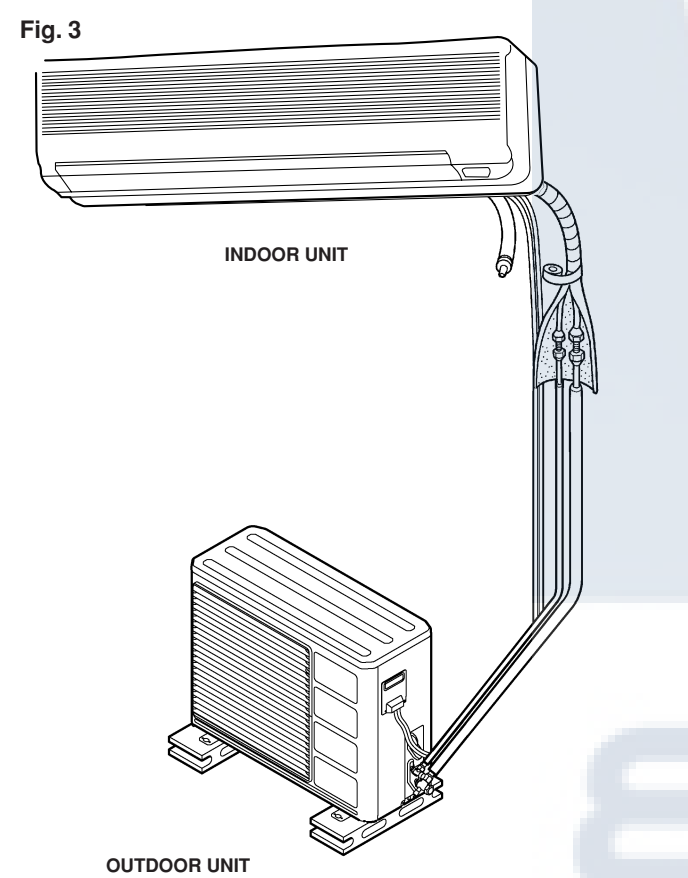
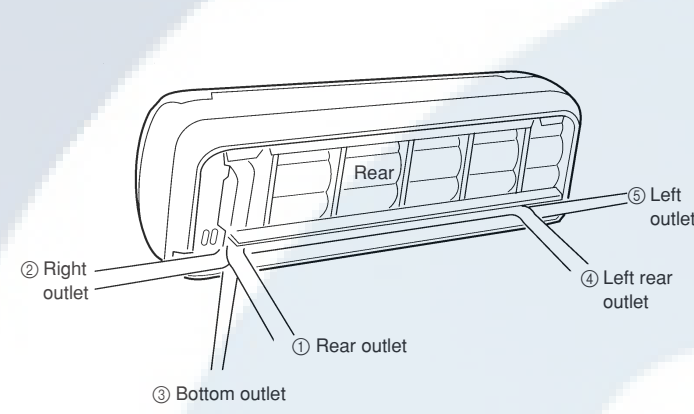

## CONNECTION PIPE REQUIREMENT

Table 2

Diameter	Small	Large
6.35 mm (1/4 in.)		12.7 mm (1/2 in.)
Maximum length	20 m (66 ft)	
Maximum Height (between indoor and outdoor)	8 m (26 ft)	

- Use pipe with water-resistant heat insulation.

## ELECTRICAL REQUIREMENT

- Electric wire size and fuse capacity.

Table 3

Connection cord (mm <sup>2</sup> )	MAX.	MIN.
2.5	2.5	1.5
Fuse capacity (A)	20	

- Install the disconnect device with a contact gap of at least 3 mm nearby the units. (Both indoor unit and outdoor unit)
- Always make the air conditioner power supply a special branch circuit and provide a special breaker.
- Always use H07RN-F or equivalent as the connection cord.

### How to use the spacer:

- Hang the indoor unit from the hooks at the top of the wall hook bracket.
- Insert the accessory spacer between the indoor unit and the wall hook bracket and separate the bottom of the indoor unit from the wall.

Fig. 12

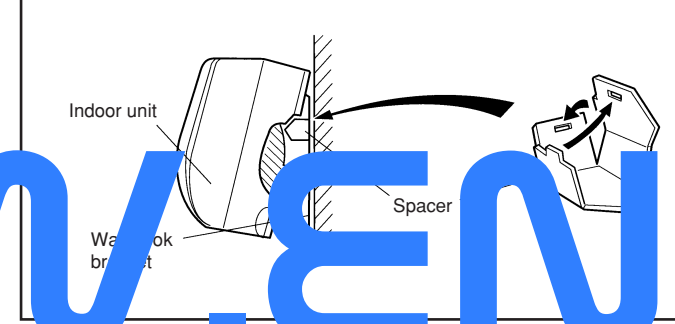

### 1. INSTALLING THE WALL HOOK BRACKET

**WARNING**  
Install the wall hook bracket so that it is strong enough to withstand the weight of an adult.

**CAUTION**  
Install the wall hook bracket so that it is correctly positioned horizontally and vertically. If the wall hook bracket is tilted, water will drip to the floor.

#### [Installation directly to a wall]

- Before fastening the wall hook bracket to the wall with the screws, level it by tapping the hook at the center of bracket to the wall with the handle of a screwdriver.
- Fasten the wall hook bracket to the wall with 6 or more screws through the holes near the outer edge of the bracket.
  - Check that there is no rattle at the wall hook bracket.

Fig. 5

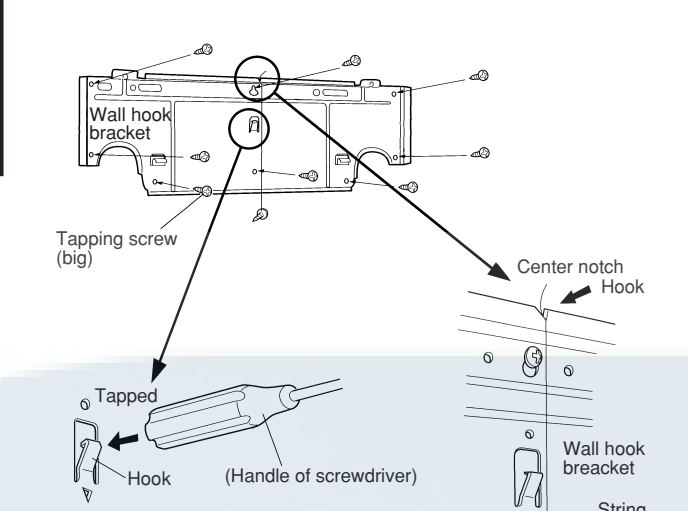

### 2. CUTTING THE HOLE IN THE WALL FOR THE CONNECTING PIPING

**WARNING**  
If the wall pipe is not used, the cord interconnecting the indoor and outdoor units may touch metal and cause electric leakage.

- Cut a 65 mm diameter hole in the wall at the position shown in (Fig. 6).
- When cutting the wall hole at the inside of the installation frame, cut the hole to a point of intersection of center marks.
- Cut the hole so that the outside end is lower (5 to 10 mm) than the inside end.
- Always align the center of the wall hole. If misaligned, water leakage will occur.
- Cut the wall pipe to match the wall thickness, stick it into the accessory wall cap, fasten the cap with vinyl tape, and stick the pipe through the hole. (Fig. 6)
- For 5 left piping and 2 right piping, cut the hole a little lower so that drain water will flow freely. (Fig. 6)

Fig. 6

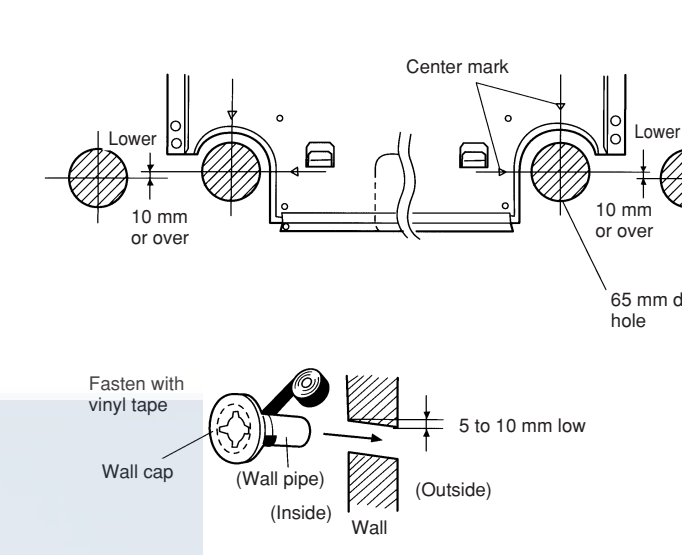

### 2 OUTDOOR UNIT INSTALLATION

**WARNING**  
(1) Install the unit where it will not be tilted by more than 5°.  
(2) When installing the outdoor unit where it may be exposed to strong wind, fasten it securely.

- Set the unit on a strong stand, such as one made of concrete blocks to minimize shock and vibration.
- Do not set the unit directly on the ground because it will cause trouble.
- Since the drain water flows out of the outdoor unit during heating operation, install the drain pipe and connect it to an commercial 16 mm hose. (Heat & Cool model (Reverse cycle) only)
- When installing the drain pipe, plug all the holes (hole at one place) other than the drain pipe mounting hole in the bottom of the outdoor unit with putty so there is no water leakage. (Fig. 13) (Heat & Cool model (Reverse cycle) only)

**CAUTION**  
Installation in cold regions. Do not use the accessory drain pipe and drain cap. (If the drain pipe and drain cap are used, the drain water in the pipe may freeze in extremely cold weather.)

Fig. 13

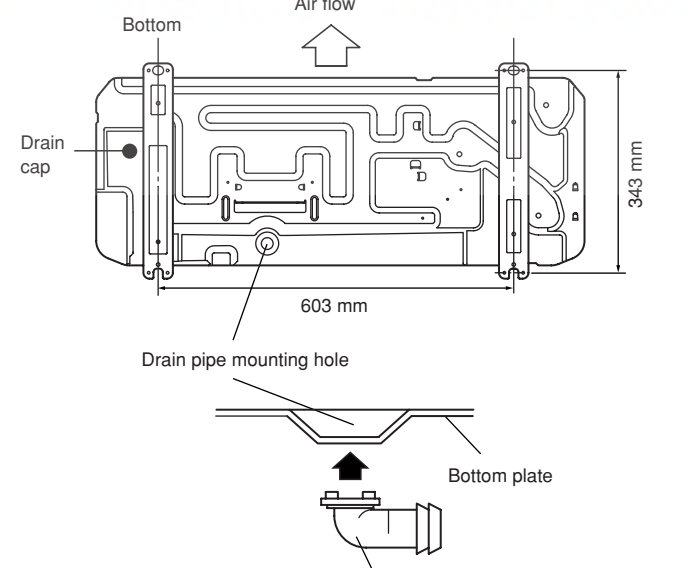

Outdoor unit connection cord and pipe connection preparations: Remove outdoor unit terminal cover.

Fig. 14

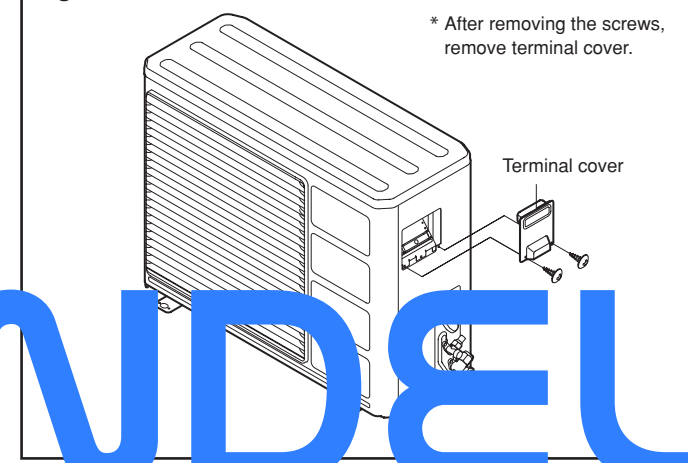

### 3 CONNECTING THE PIPING

**WARNING**  
Do not use the existing (for R22) piping and flare nuts.  
• If the existing materials are used, the pressure inside the refrigerant cycle will rise and cause breakage, injury, etc. (Use the special R410A materials.)

**CAUTION**  
(1) Do not use mineral oil on flared part. Wrap the pipes of the indoor unit that are visible from the outside with decorative tape.  
(2) While welding the pipes, be sure to blow dry nitrogen gas through them.  
(3) The maximum lengths of this product are shown in table 2. If the units are further apart than this, correct operation can not be guaranteed.

#### 1. FLARING

- Cut the connection pipe to the necessary length with a pipe cutter.
- Hold the pipe downward so that cuttings will not enter the pipe and remove the burrs.
- Insert the flare nut (always use the flare nut attached to the indoor and outdoor units respectively) onto the pipe and perform the flare processing with a flare tool. Use the special R410A flare tool, or the conventional (for R22) flare tool. When using the conventional flare tool, always use an allowance adjustment gauge and secure the A dimension shown in table 4.

Fig. 15

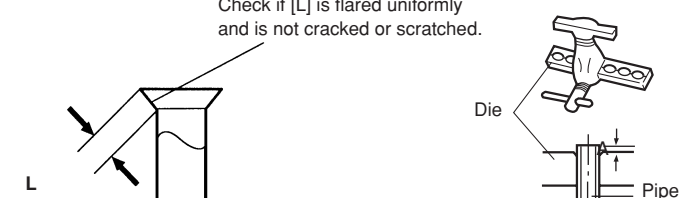

Table 4 Pipe outside diameter

Pipe outside diameter	A (mm)		
	Flare tool for R410A, clutch type	Conventional (R22) flare tool, Clutch type	Wing nut type
6.35 mm (1/4 in.)	0 to 0.5	1.0 to 1.5	1.5 to 2.0
12.7 mm (1/2 in.)	0 to 0.5	1.0 to 1.5	2.0 to 2.5

#### 2. BENDING PIPES

- When bending the pipe, be careful not to crush it.
- To prevent crushing of the pipe, do not bend the pipe at a radius curvature of 100 mm or over.
- If the copper pipe is bent the pipe or pulled to often, it will become stiff. Do not bend the pipes more than three times at one place.

#### 3. CONNECTION

- Install the outdoor unit wall cap (supplied with the optional installation set or procured at the site) to the wall hole pipe.
- Connect the outdoor unit connection cord to the wall cap, and tighten it with a torque wrench.
- Connect the outdoor unit connection cord to the wall cap, and tighten it with a torque wrench.

### 3. FORMING THE DRAIN HOSE AND PIPE

**CAUTION**

- Do not remove the flare nut from the indoor unit pipe until immediately before connecting the connection pipe.
- To prevent breaking of the pipe, avoid sharp bends. Bend the pipe with a radius of curvature of 100 mm or over.
- If the pipe is bent repeatedly at the same place, it will break.

#### [Rear piping, Right piping, Bottom piping]

- Install the indoor unit piping in the direction of the wall hole and bend the drain hose and pipe together with vinyl tape. (Fig. 7)
- Install the piping so that the drain hose is at the bottom.

Fig. 7

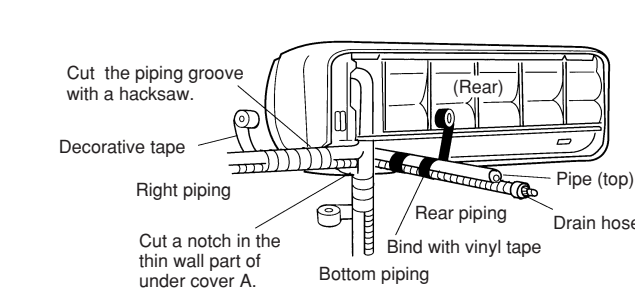

- Perform "ELECTRICAL WRING" before performing this piping.
- Wrap the pipes of the indoor unit that are visible from the outside with decorative tape.
- After passing the indoor piping and drain hose through the wall hole, hang the indoor unit on the hooks at the top and bottom of the wall hook bracket.

Fig. 8

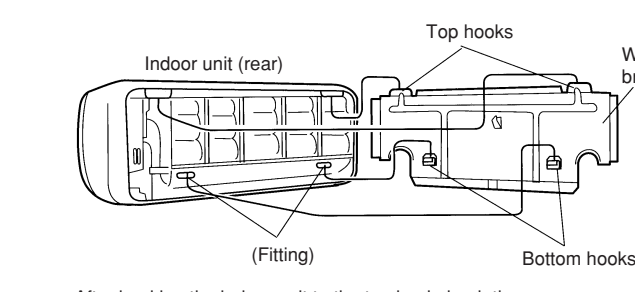

After hooking the indoor unit to the top hook, hook the fittings of the indoor unit to the two bottom hooks while lowering the unit and pushing it against the wall.

- Piping work can be made easier by laying out, shaping, and temporarily fastening the connection pipe, drain hose, and connection cord as shown in (Fig. 11) beforehand.

### [④ Left rear piping, ⑤ Left piping]

**CAUTION**

After removing the drain hose, do not forget to install the drain cap.

- Remove the hose clamp and install the drain hose and drain cap at the left and right. Then reinstall the hose clamp at its original position.

Fig. 9

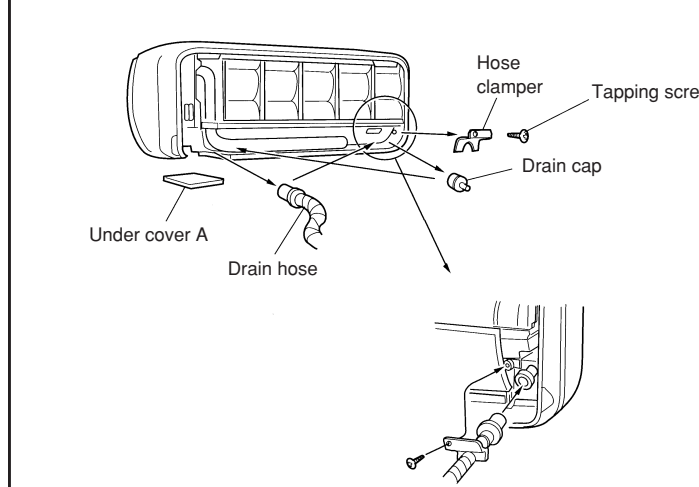

For ④ Left rear piping and ⑤ Left piping, perform CONECTING THE PIPING simultaneously.

Fig. 10

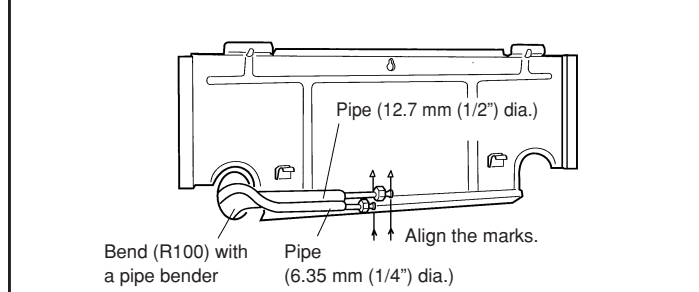

- Align the marks on the wall hook bracket and shape the connection pipe.
- Bend (about R100) the outlet section from the wall of left rear piping with a pipe bender and shape it as shown in (Fig. 10) so that there is no space between the pipe and the wall.

4

VACUUM PROCESS

2. ADDITIONAL CHARGE

CAUTION (1) Do not purge the air with refrigerants but use a vacuum pump to vacuum the installation! There is no extra refrigerant in the outdoor unit for air purging! (2) Use a vacuum pump for R410A exclusively. Using the same vacuum pump for different refrigerants may damage the vacuum pump or the unit.

Table 7: Refrigerant suitable for a piping length of 7.5 m is charged in the outdoor unit at the factory. Table with columns: Pipe length, Additional refrigerant, g/m, oz/ft.

1. VACUUM (1) Remove the cap, and connect the gauge manifold and the vacuum pump to the charging valve by the service hoses. (2) Vacuum the indoor unit and the connecting pipes until the pressure gauge indicates -0.1 MPa (-76 cmHg). (3) When -0.1 MPa (-76 cmHg) is reached, operate the vacuum pump for at least 15 minutes. (4) Disconnect the service hoses and fit the cap to the charging valve to the specified torque. (5) Remove the blank caps, and fully open the spindles of the 2-way and 3-way valves with a hexagon wrench (Torque : 6 to 7 N · m (60 to 70 kgf · cm). (6) Tighten the blank caps of the 2-way valve and 3-way valve to the specified torque.

(1) When moving and installing the air conditioner, do not mix gas other than the specified refrigerant (R410A) inside the refrigerant cycle. (2) When charging the refrigerant R410A, always use an electronic balance for refrigerant charging (to measure the refrigerant by weight). (3) When charging the refrigerant, take into account the slight change in the composition of the gas and liquid phases, and always charge from the liquid phase side whose composition is stable. (4) Add refrigerant from the charging valve after the completion of the work. (5) If the units are further apart than the maximum pipe length, correct operation can not be guaranteed.

3. GAS LEAKAGE INSPECTION

After connecting the piping, check the joints for gas leakage with gas leak detector.

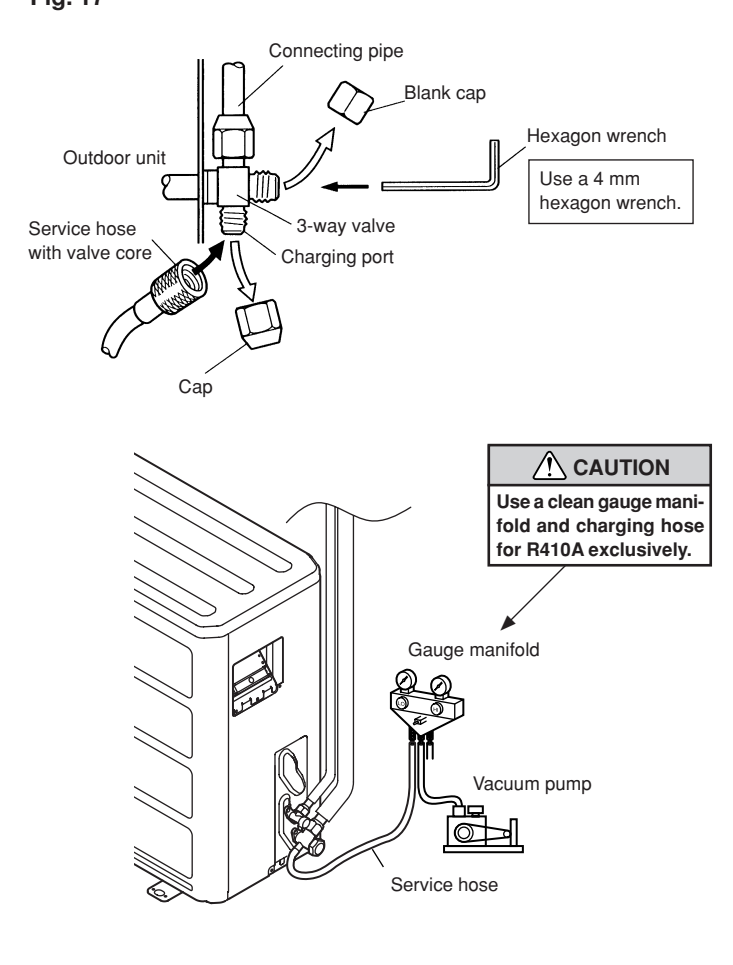

6

FINISHING

(2) Temporarily fasten the connection cord along the connection pipe with vinyl tape. (Wrap to about 1/3 the width of the tape from the bottom of the pipe so that water does not enter.) (3) Fasten the connection pipe to the outside wall with a saddle, etc. (4) Fill the gap between the outside wall pipe hole and the pipe with sealer so that rain water and wind cannot blow in.

1. CONNECTION PIPE, CORD AND DRAIN HOSE (1) Insulate between pipes. (1) For rear, right, and bottom piping, overlap the connection pipe heat insulation and indoor unit pipe heat insulation and bind them with vinyl tape so that there is no gap. (2) For left and left rear piping, butt the connection pipe heat insulation and indoor unit pipe heat insulation together and bind them with seal A and vinyl tape so that there is no gap.

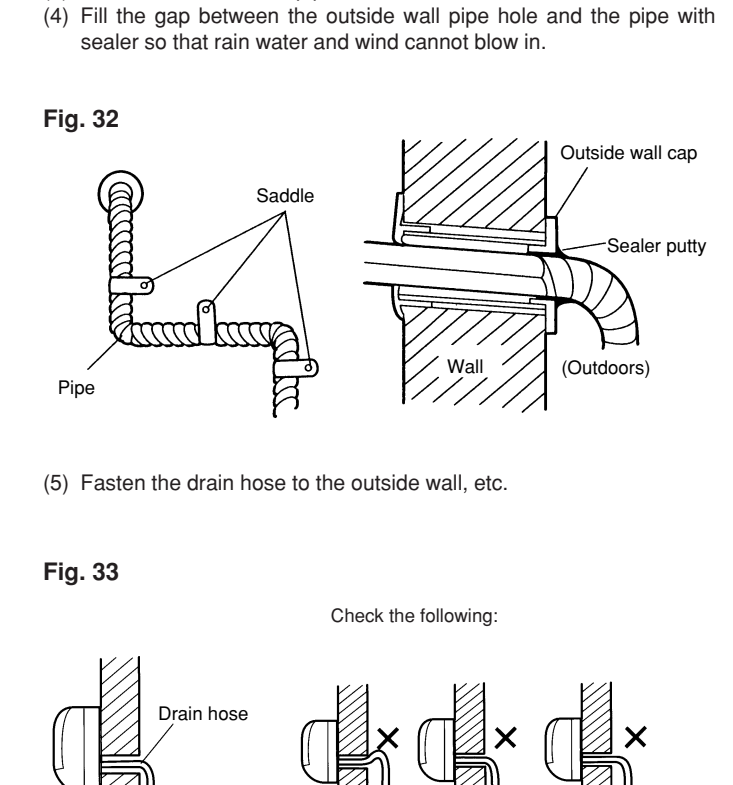

Fig. 28, 29, 30, 31: Diagrams and checklists for finishing steps, including pipe insulation, cloth taping, and hooking the indoor unit to the wall.

5

ELECTRICAL WIRING

WARNING (1) Before starting work, check that power is not being supplied to indoor unit and the outdoor unit. (2) Match the terminal block numbers and connection cord colors of the indoor unit and the outdoor unit. Erroneous wiring may cause burning of the electric parts. (3) Connect the connection cords firmly to the terminal block. Imperfect installation may cause a fire. (4) Always fasten the outside covering of the connection cord with the cord clamp. (If the insulator is chafed, electric leakage may occur.) (5) Always connect the ground wire.

HOW TO CONNECT WIRING TO THE TERMINALS

A. For solid core wiring (or F-cable) (1) Cut the wire end with a wire cutter or wire-cutting pliers, then strip the insulation to about 25 mm (1 5/16") to expose the solid wire. (2) Using a screwdriver, remove the terminal screw(s) on the terminal board. (3) Using pliers, bend the solid wire to form a loop suitable for the terminal screw. (4) Shape the loop wire properly, place it on the terminal board and tighten securely with the terminal screw using a screwdriver. B. For strand wiring (1) Cut the wire end with a wire cutter or wire-cutting pliers, then strip the insulation to about 10 mm (3/8") to expose the strand wiring. (2) Using a screwdriver, remove the terminal screw(s) on the terminal board. (3) Using a round terminal fastener or pliers, securely clamp a round terminal to each stripped wire end. (4) Position the round terminal wire, and replace and tighten the terminal screw using a screwdriver.

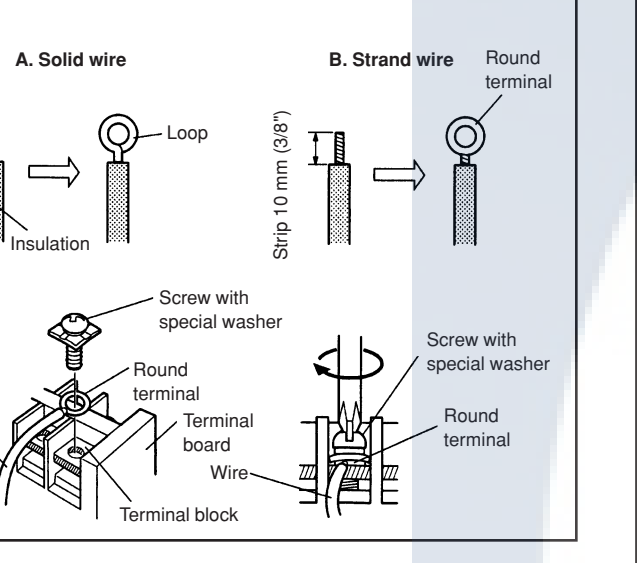

1. CONNECTION DIAGRAM

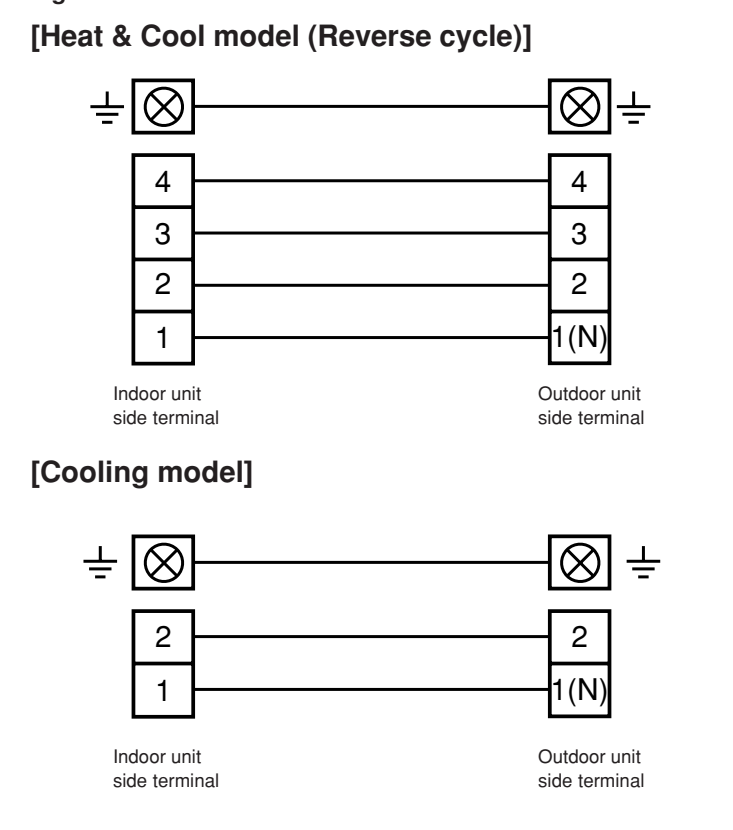

2. INDOOR UNIT SIDE (Heat & Cool model (Reverse cycle)) (1) Remove the under cover A. (2) Remove the front panel. (3) Remove the cable clamp. (4) Process the end of the connection cords to the dimensions shown in (Fig.21) and bend the end of each cord as shown in (Fig.20). (5) Remove the cable clamp. (6) Connect the end of the connection cord fully into the terminal block and fasten with a screw. (Cooling model) (1) Remove the under cover A. (2) Remove the front panel. (3) Remove the cable clamp. (4) Process the end of the connection cords to the dimensions shown in (Fig.23) and bend the end of each cord as shown in (Fig.23). (5) Connect the end of the connection cord fully into the terminal block and fasten with a screw.

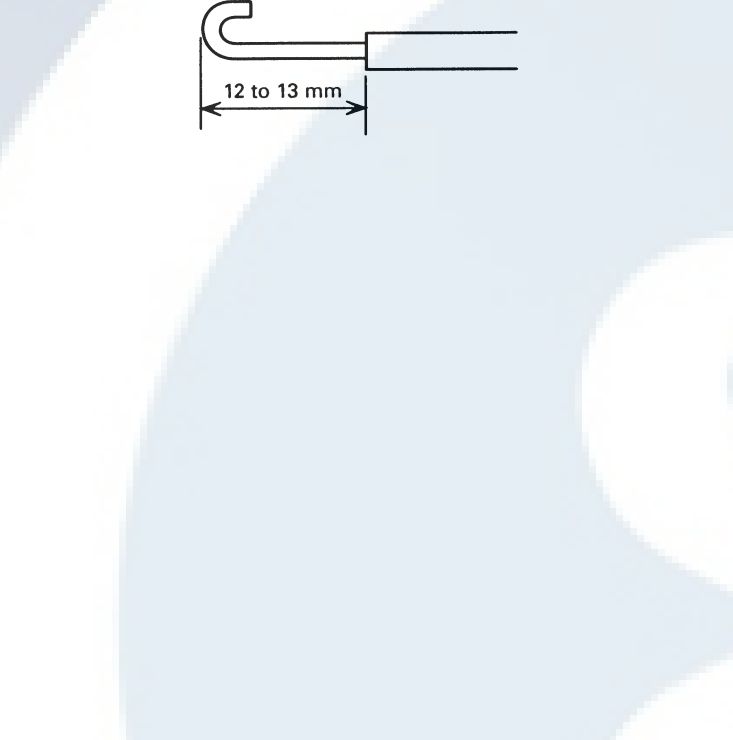
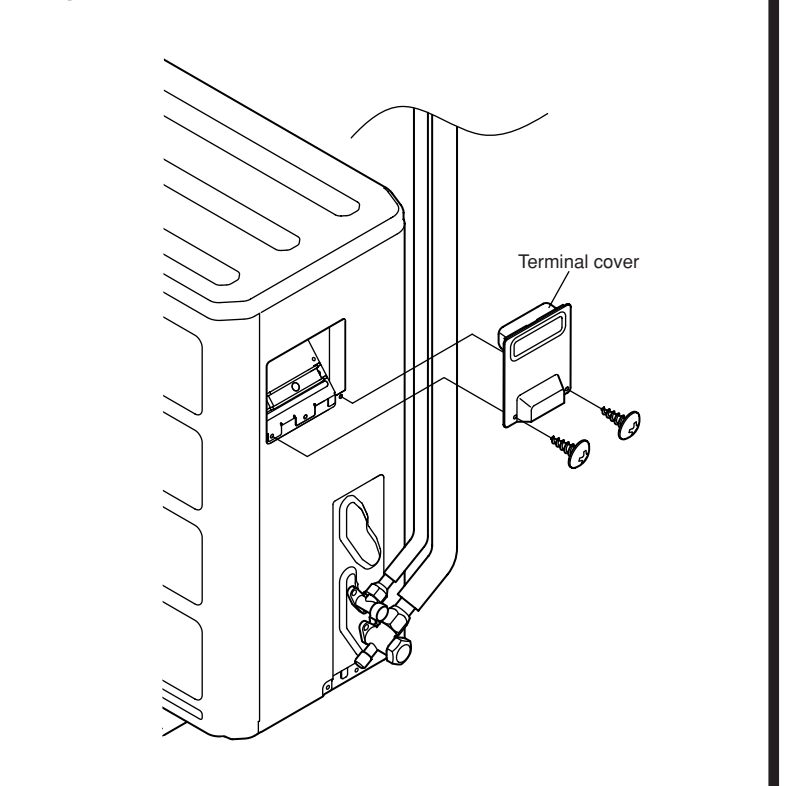
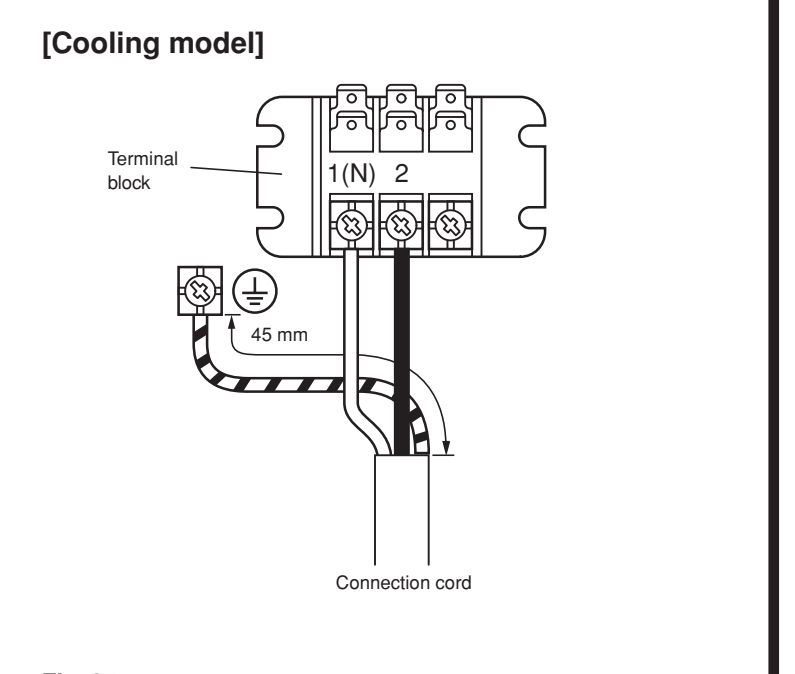
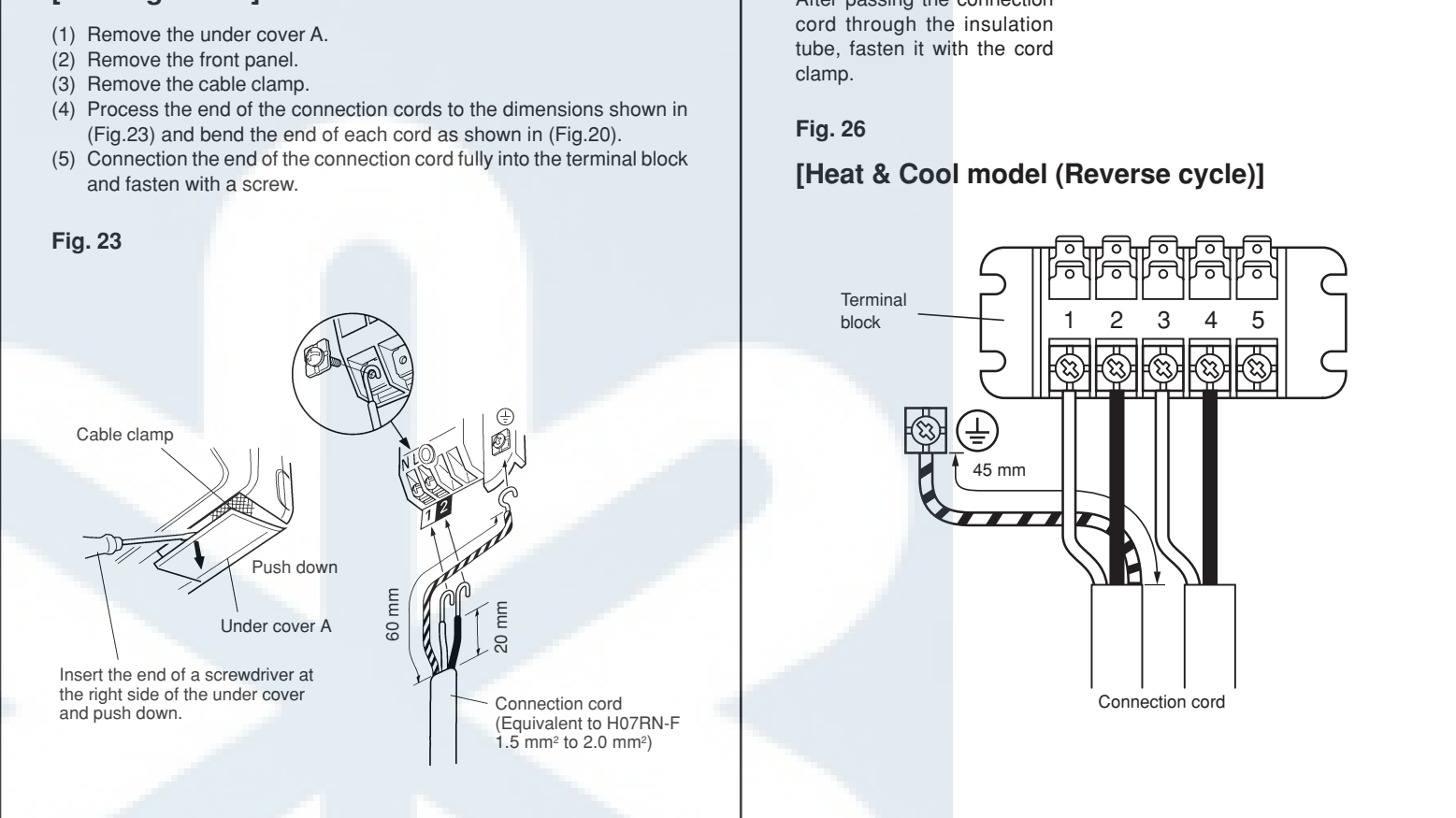
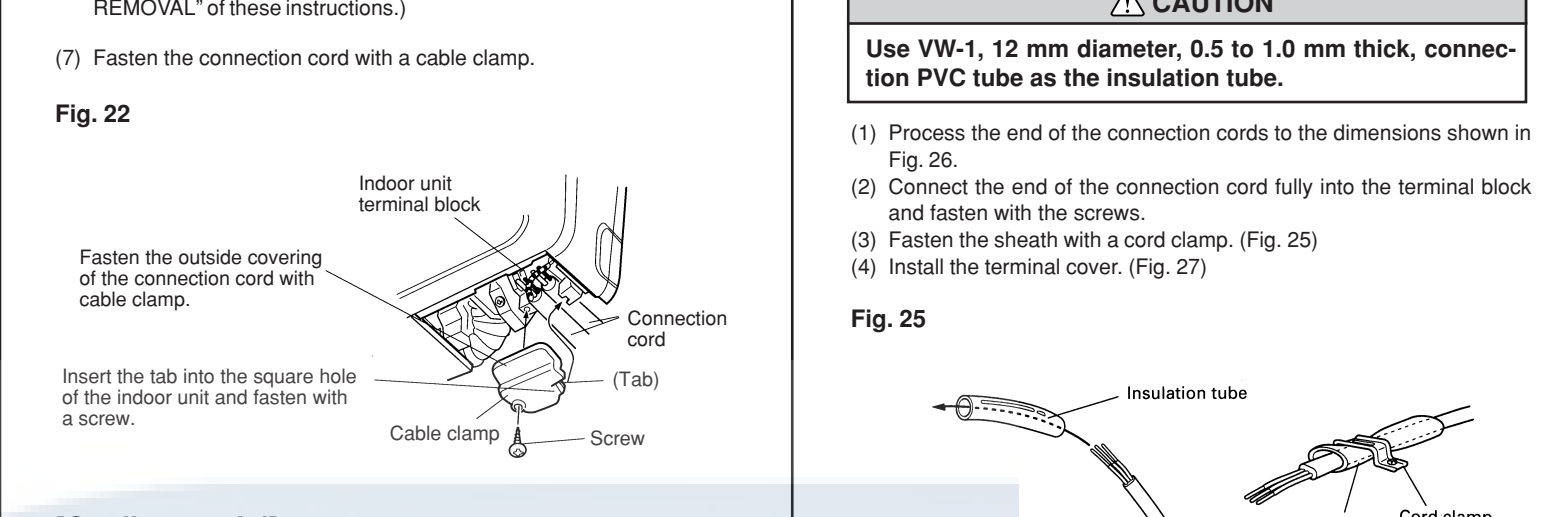

Fig. 21 (Remove the front panel in accordance with 'FRONT PANEL REMOVAL' of these instructions.) (6) Fasten the connection cord with a cable clamp. Fig. 24 (Remove the front panel in accordance with 'FRONT PANEL REMOVAL' of these instructions.) (7) Fasten the connection cord with a cable clamp. Fig. 22 (Remove the front panel in accordance with 'FRONT PANEL REMOVAL' of these instructions.) (7) Fasten the connection cord with a cable clamp. Fig. 25 (Remove the front panel in accordance with 'FRONT PANEL REMOVAL' of these instructions.) (7) Fasten the connection cord with a cable clamp.



7

POWER

(1) The rated voltage of this product is 230 V A.C. 50 Hz. (2) Before turning on the verify that the voltage is within the 198 V to 264 V range. (3) Always use a special branch circuit and install a special breaker to supply power to the room air conditioner. (4) Use a circuit breaker matched to the capacity of the room air conditioner. (Install in accordance with standard). (5) The circuit breaker is installed in the permanent wiring. Always use a circuit that can trip all the poles of the wiring and has an isolation distance of at least 3 mm between the contacts of each pole. (6) Perform wiring work in accordance with standards so that the room air conditioner can be operated safely and positively. (7) Install a leakage circuit breaker in accordance with the related laws and regulations and electric company standards.

CAUTION (1) The power source capacity must be the sum of the room air conditioner current and the current of other electrical appliances. When the current contracted capacity is insufficient, change the contracted capacity. (2) When the voltage is low and the air conditioner is difficult to start, contact the power company the voltage raised.

8

TEST RUNNING

(1) Perform test operation and check items 1 and 2 below. (2) For the operation method, refer to the operating manual. (3) The outdoor unit may not run, depending on the room temperature. In this case, press the test run button at the back of the remote controller while the room air conditioner is running. (With the transmit section of the remote controller facing the body, press the test run button with the tip of a ball point pen.) (4) To end test operation, press the remote controller START/STOP button. (When the power is turned on for the first time after unpacking, the RUN and TIMER lamps will alternately flash rapidly. When operation starts, the flashing stops. Thereafter, when the power is turned off and then turned on, operation immediately before the power was turned off, or the stop state, will be automatically reproduced.) (When the room air conditioner is run by pressing the remote controller test run button, the RUN and TIMER lamps will simultaneously flash slowly.)

(1) INDOOR UNIT (1) Is operation of each button on the remote controller normal? (2) Does each lamp light normally? (3) Do the air flow direction louvers operate normally? (4) Is the drain normal? (2) OUTDOOR UNIT (1) Is there any abnormal noise and vibration during operation? (2) Will noise, wind, or drain water from the unit disturb the neighbors? (3) Is there any gas leakage?

9

REMOTE CONTROL UNIT INSTALLATION

CAUTION (1) Check that the indoor unit correctly receives the signal from the remote control unit, then install the remote control unit holder. (2) Select the remote control unit holder selection site by paying careful attention to the following: Avoid places in direct sunlight. Select a place that will not be affected by the heat from a stove, etc. 1. REMOTE CONTROL UNIT HOLDER INSTALLATION (1) Install the remote controller holder to a wall or pillar with the tapping screws. Fig. 38 (1) Set the remote control unit holder selection site by paying careful attention to the following: Avoid places in direct sunlight. Select a place that will not be affected by the heat from a stove, etc.

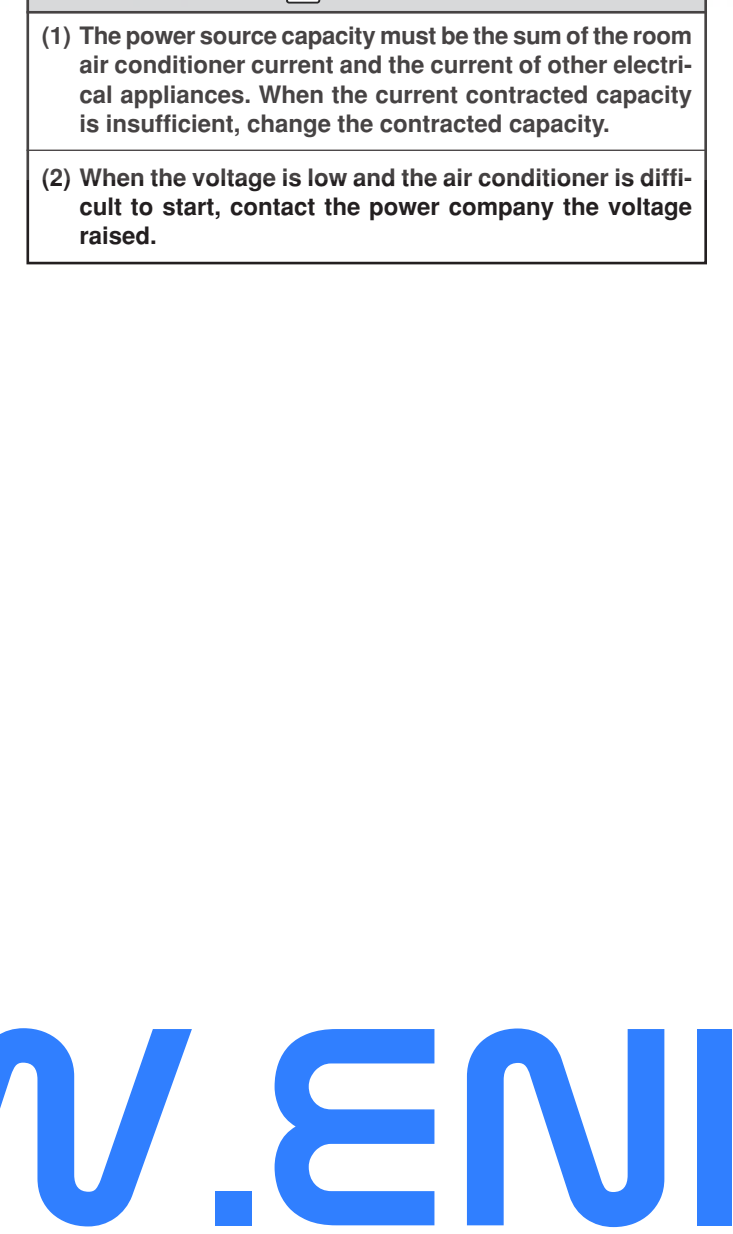

10

FRONT PANEL REMOVAL

CAUTION (1) Install the front panel and intake grille securely. If installation is imperfect, the front panel or intake grille may fall off and cause injury. 1. INTAKE GRILLE REMOVAL (1) Open the intake grille. (2) Open the intake grille further and lift off the grille. Fig. 39 (1) Open the intake grille. (2) Open the intake grille further and lift off the grille.

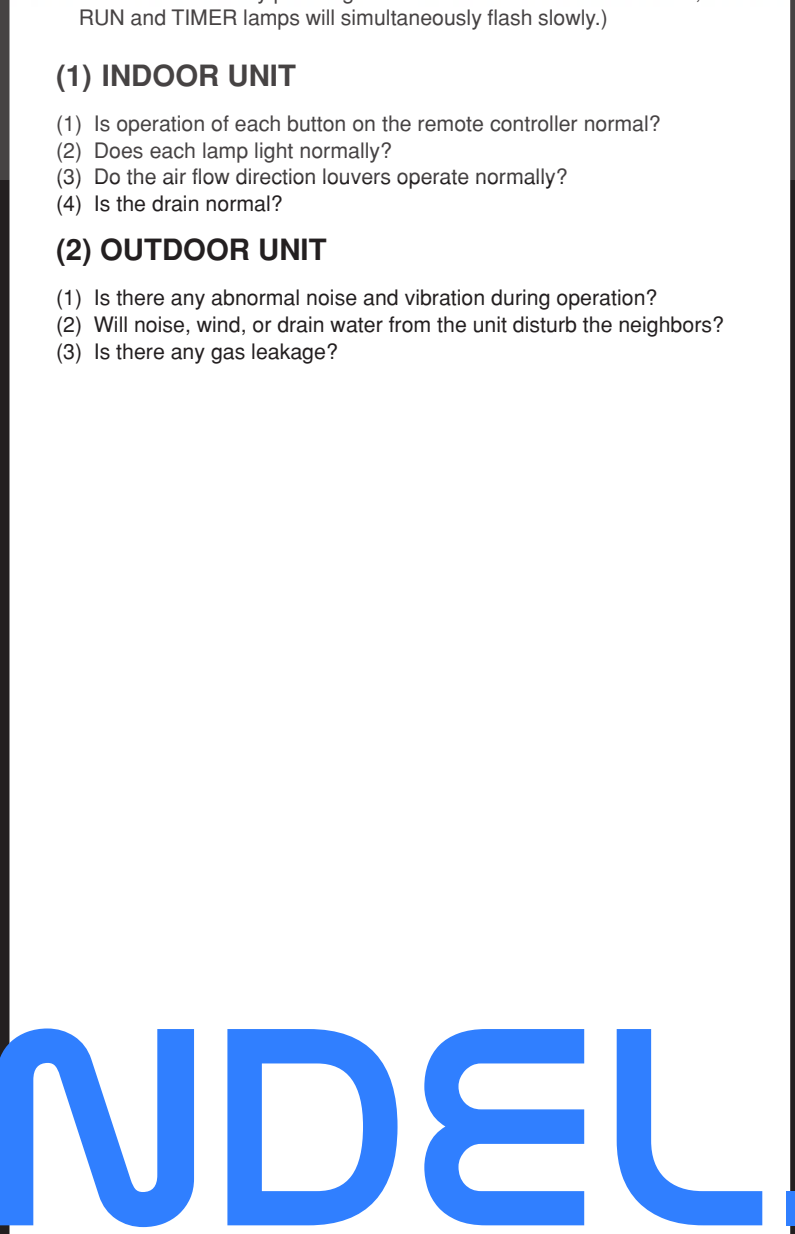

11

CUSTOMER GUIDANCE

Explain the following to the customer in accordance with the operating manual: (1) Starting and stopping method, operation switching, temperature adjustment, timer, air flow switching, and other remote control unit operations. (2) Air filter removal and cleaning, and how to use the air louvers. (3) Give the operating manual and installation instruction sheet to the customer. (4) If the signal code is changed, explain to the customer how it changed (the system returns to signal code A when the batteries in the remote control unit are replaced).

