

# SERVICE MANUAL

Refrigerant  
**R410A**

Models

Indoor unit                  Outdoor unit

**ASG17FSBQ      AOG17FNBK**  
**ASG17USBQ      AOG17UNBK**  
( made in Thailand )

**ASG17FSCQ      AOG17FNBN**  
**ASG17USCQ      AOG17UNBN**  
( made in China )

**ENINDEL CLIMA**

## CONTENTS

SPECIFICATIONS .....	1
OUTLINE AND DIMENSIONS .....	2
REFRIGERANT SYSTEM DIAGRAM .....	3
CIRCUIT DIAGRAM .....	4
PRINTED CIRCUIT BOARD CIRCUIT DIAGRAM .....	6
DISASSEMBLY ILLUSTRATION .....	8
PARTS LIST .....	14

# SPECIFICATIONS

INDOOR UNIT	ASG17FSBQ ASG17FSCQ	ASG17USBQ ASG17FSCQ
OUTDOOR UNIT	AOG17FNBK AOG17FNBN	AOG17UNBK AOG17UNBN
COOLING CAPACITY (kW)	4.70	4.70
HEATING CAPACITY (kW)	-	5.40

## ELECTRICAL DATA

POWER SOURCE (V)	230		
FREQUENCY (Hz)	50		
RUNNING CURRENT (A)	COOLING	8.3	7.9
	HEATING	-	8.9
INPUT WATTS (kW)	COOLING	1.85	1.76
	HEATING	-	1.99
E.E.R. (kW/kW)	COOLING	2.54	2.67
	HEATING	-	2.71
MOISTURE REMOVAL (ℓ/hr)	2.1		
AIR CIRCULATION-Hi (m <sup>3</sup> /hr)	560		

## COMPRESSOR

TYPE	Hermetic type, Permanent split condenser, 2 pole, Single phase, Induction motor, Rotary
DISCRIMINATION	5KS225DAC

## FAN MOTOR

POWER SOURCE	230	
DISCRIMINATION (INDOOR UNIT)	MFA - 17AT	
FAN SPEED (r.p.m.)	HI-SPEED	1,300
	MED-SPEED	1,210
	LO-SPEED	1,110
DISCRIMINATION (OUTDOOR UNIT)	MFB - 24JTT	
FAN SPEED (r.p.m.)	780	

## DIMENSIONS

INDOOR UNIT	H x W x D (mm)	285 x 900 x 172
OUTDOOR UNIT	H x W x D (mm)	650 x 830 x 320

## WEIGHT

INDOOR UNIT	GROSS / NET (kg)	13 / 10	
OUTDOOR UNIT	GROSS / NET (kg)	51 / 47	56 / 52

## REFRIGERANT CHARGE (R410A)

FULL CHARGE AMOUNT	Pipe Length	25 ft ( 7.5 m )	28.2 oz ( 800 g )	44.1 oz ( 1,250 g )
		33 ft ( 10 m )	29.5 oz ( 838 g )	45.4 oz ( 1,288 g )
		49 ft ( 15 m )	32.2 oz ( 913 g )	48.1 oz ( 1,363 g )
		66 ft ( 20 m )	34.8 oz ( 988 g )	50.7 oz ( 1,438 g )

Note : Between 7.5 m and 20 m, when using a connection pipe other than that in the table, charge additional refrigerant with 0.53 oz (15 g) / 3.3 ft (1 m) as the criteria.

# OUTLINE AND DIMENSIONS

Unit : mm

## INDOOR UNIT

Models : ASG17FSBQ  
ASG17USBQ  
ASG17FSCQ  
ASG17USCQ

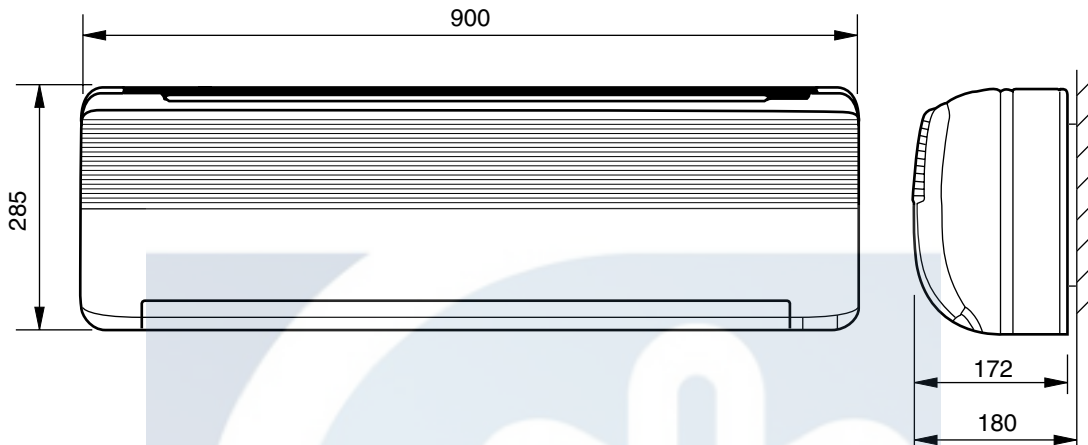

## OUTDOOR UNIT

Models : AOG17FNBK  
AOG17UNBK  
AOG17FNBN  
AOG17UNBN

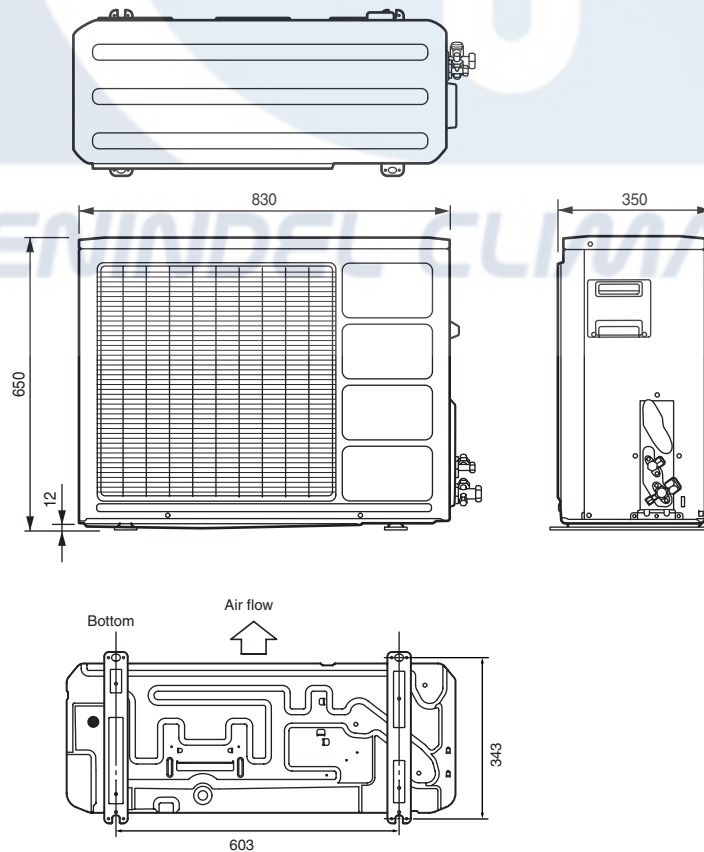

# REFRIGERANT SYSTEM DIAGRAM

Models : ASG17FSBQ / AOG17FNBK  
 ASG17FSCQ / AOG17FNBN

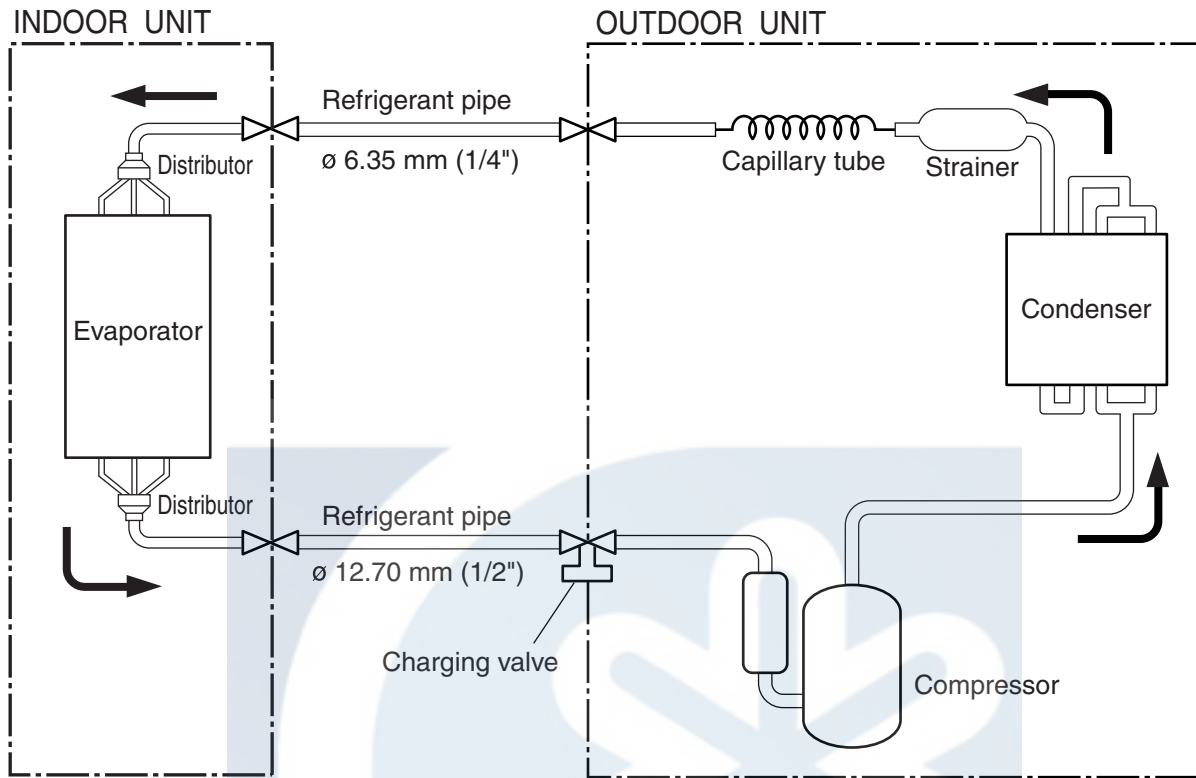

Models : ASG17USBQ / AOG17UNBK  
 ASG17USCQ / AOG17UNBN

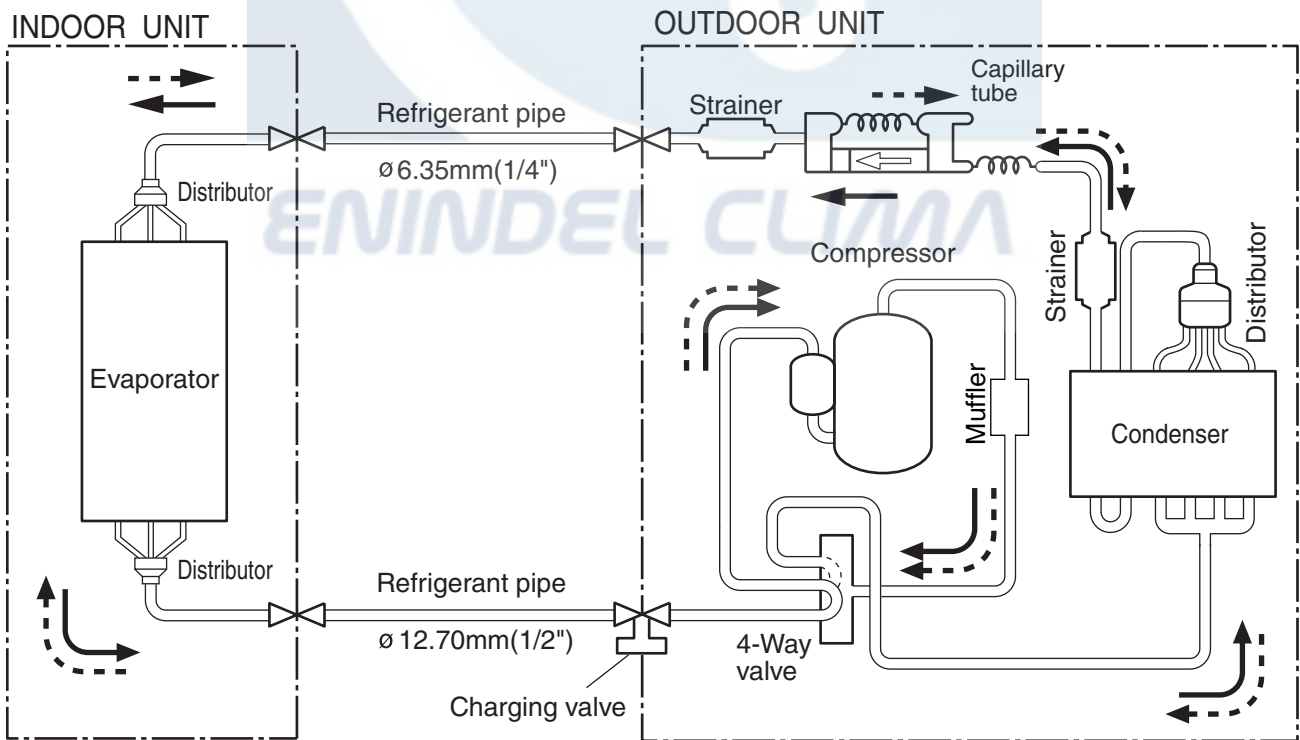

- Cooling
- Heating
- Flare coupling

# CIRCUIT DIAGRAM

Models : ASG17FSBQ / AOG17FNBK  
ASG17FSCQ / AOG17FNBN

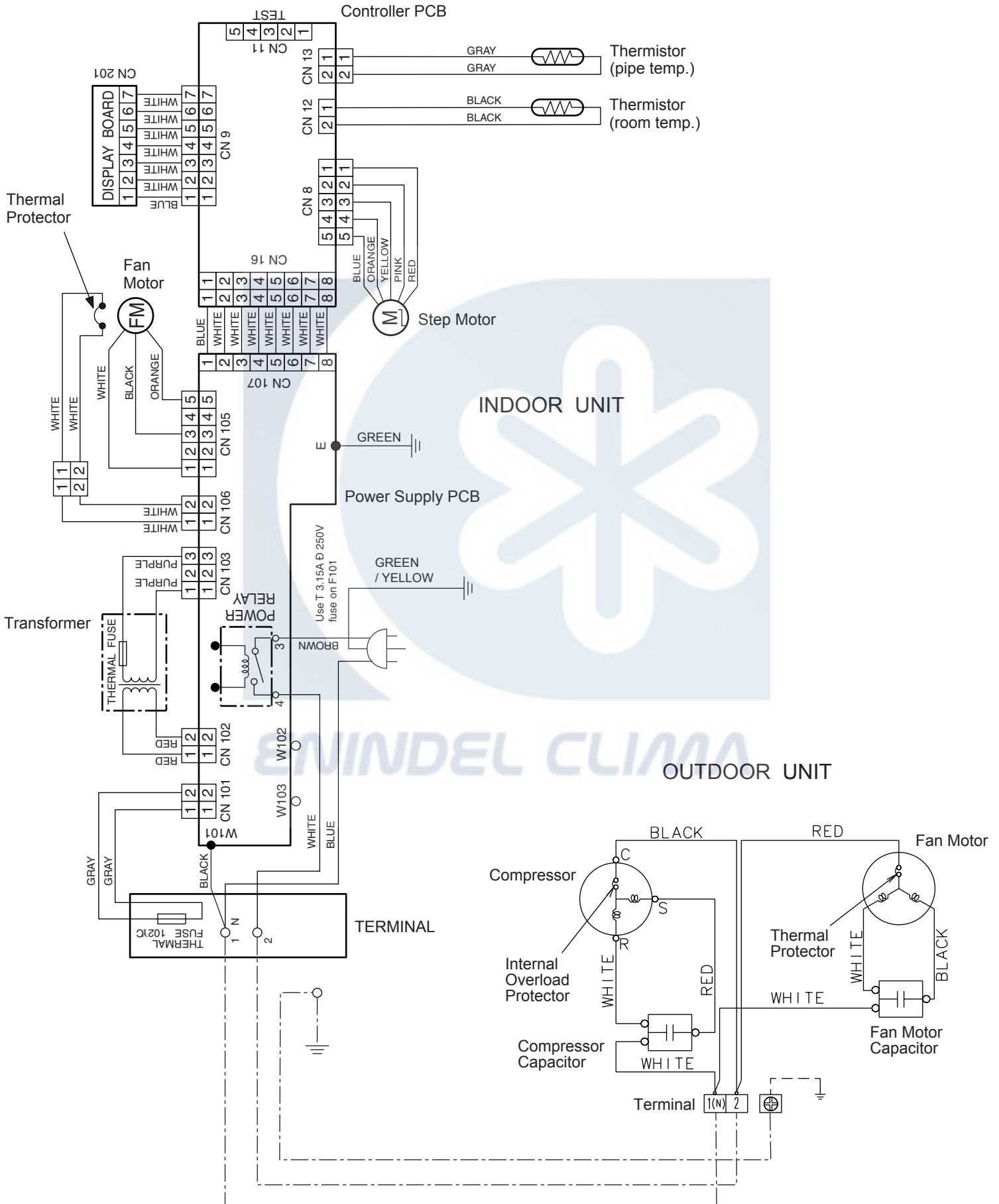

**Models : ASG17USBQ / AOG17UNBK  
ASG17USCQ / AOG17UNBN**

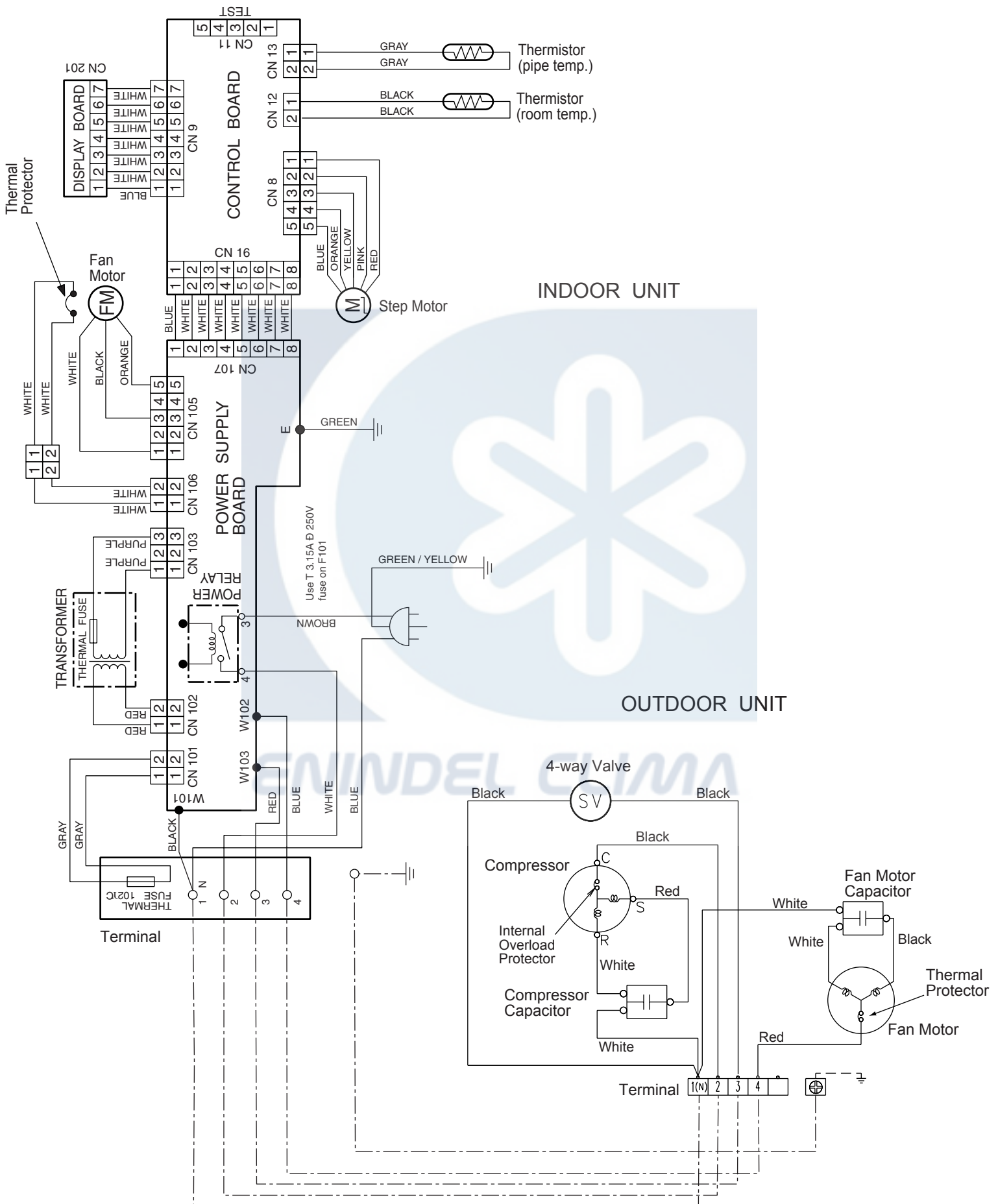

# INDOOR PCB CIRCUIT DIAGRAM

Model :  
ASG17FSBQ  
ASG17FSCQ

## Jumper wire configurations

Switch	Function	ON/Linked	OFF/Open
JP 1/2/3/4	Model change over	(Depends on model)	
JP5	Custom code	A	B
JP6	Auto change-over	enable	disable
JP-7/8	Heating compensation	(See table 3)	
JP9	Auto restart	enable	disable
JP10	Multi/single	(not in use)	(not in use)
JP11	Up-Down airflow flap	(not in use)	(not in use)
JP12	Outdoor fan delay	(not in use)	(not in use)

Table 3

ON / ON	+4
ON / OFF	0
OFF / ON	-2
OFF / OFF	+2

## POWER SUPPLY PCB EZ-097VWSE-P

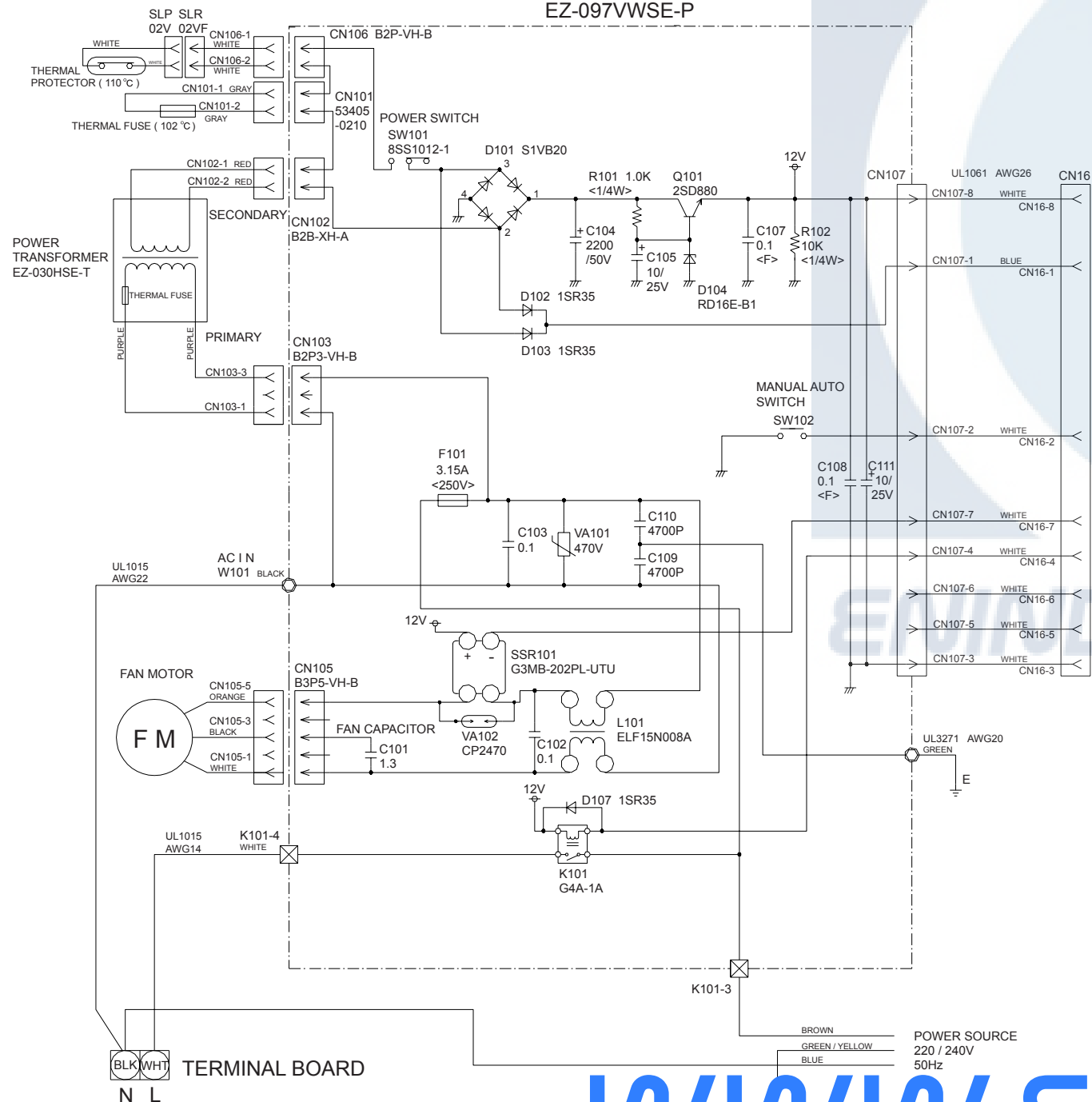

## CONTROLLER PCB ASSEMBLY ( MAIN PCB ) EZ-099MWSE-C ( F )

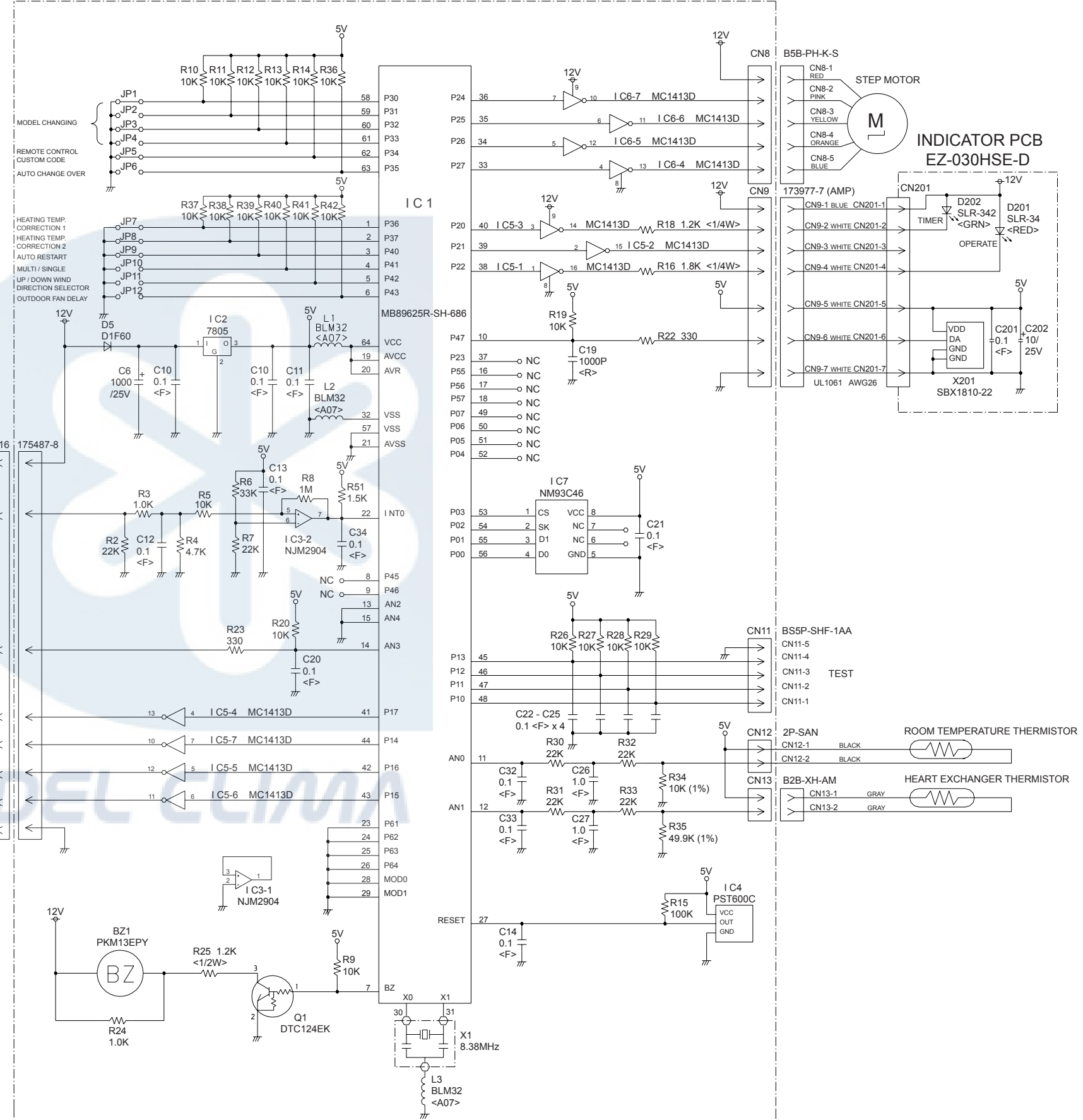

Model :  
 ASG17USBQ  
 ASG17USCQ

CONTROLLER PCB ASSEMBLY ( MAIN PCB )  
 EZ-099THSE-C ( F )

Jumper wire configurations

Switch	Function	ON/Linked	OFF/Open
JP 1/2/3/4	Model change over	(Depends on model)	
JP5	Custom code	A	B
JP6	Auto change-over	enable	disable
JP-7/8	Heating compensation	(See table 3)	
JP9	Auto restart	enable	disable
JP10	Multi\single	(not in use)	(not in use)
JP11	Up-Down airflow flap	(not in use)	(not in use)
JP12	Outdoor fan delay	(not in use)	(not in use)

Table 3

ON / ON	+4
ON / OFF	0
OFF / ON	-2
OFF / OFF	+2

POWER SUPPLY PCB  
 EZ-097THSE-P

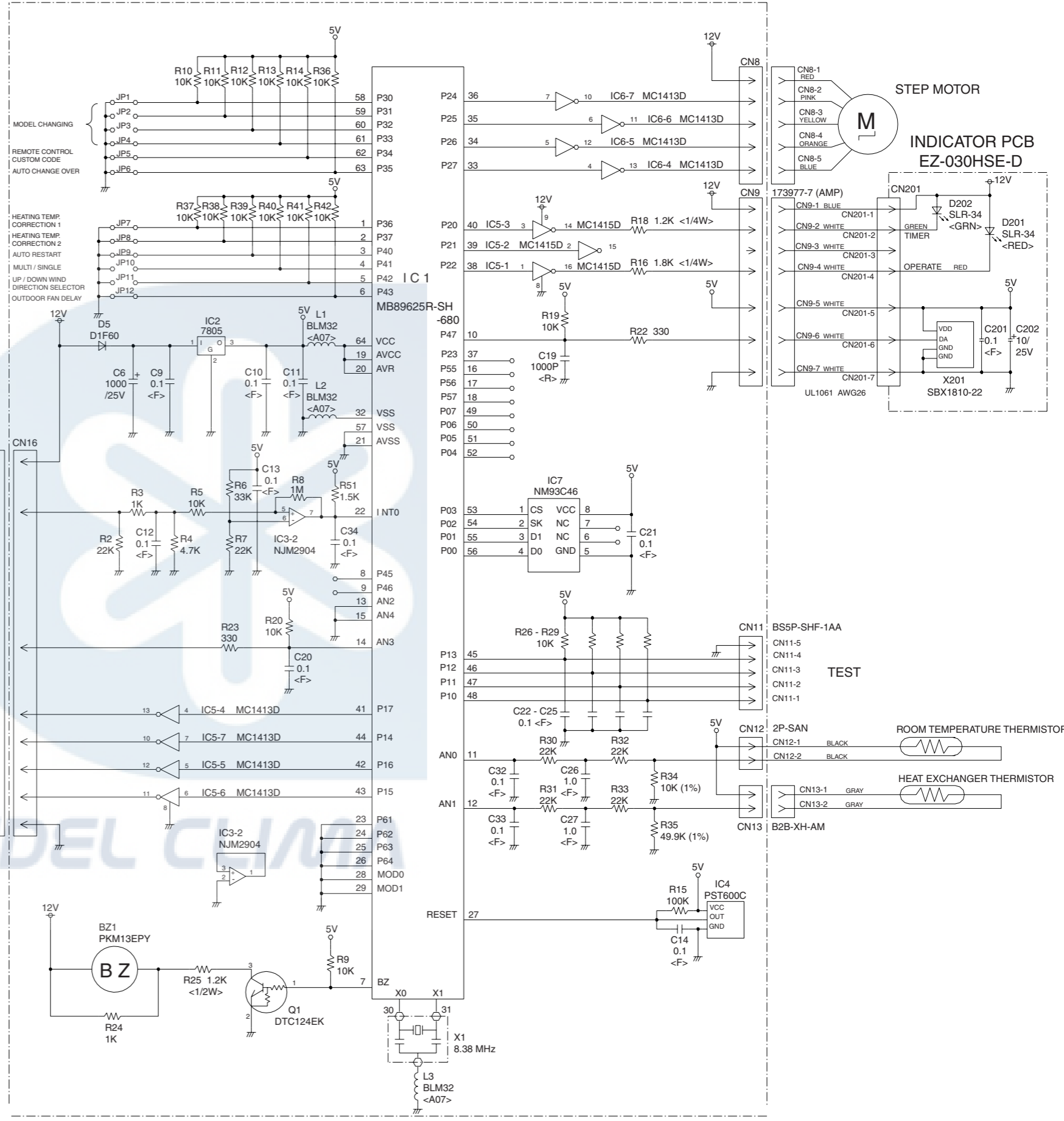
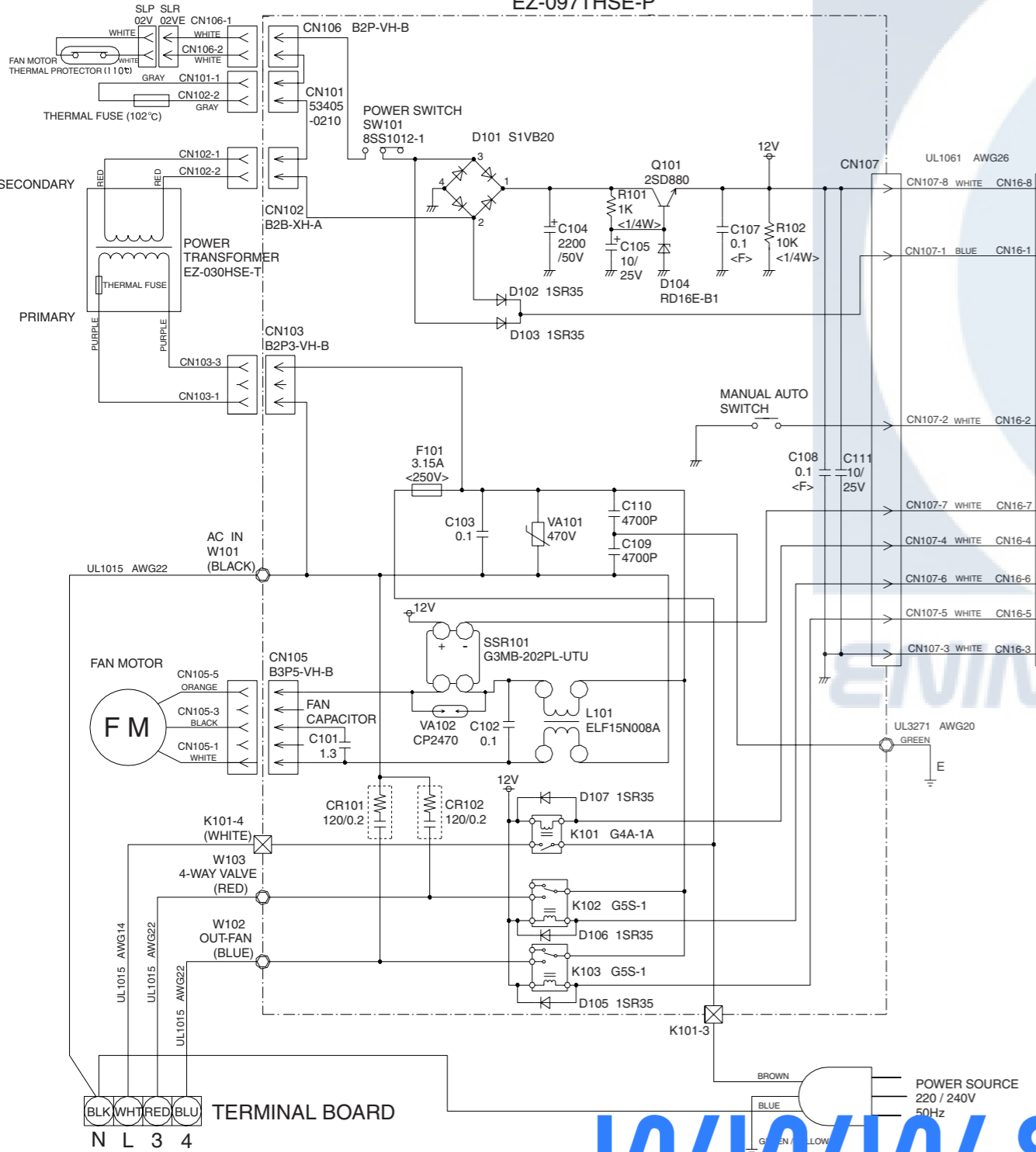



# DISASSEMBLY ILLUSTRATION

Models : ASG17FSBQ  
ASG17USBQ  
ASG17FSCQ  
ASG17USCQ

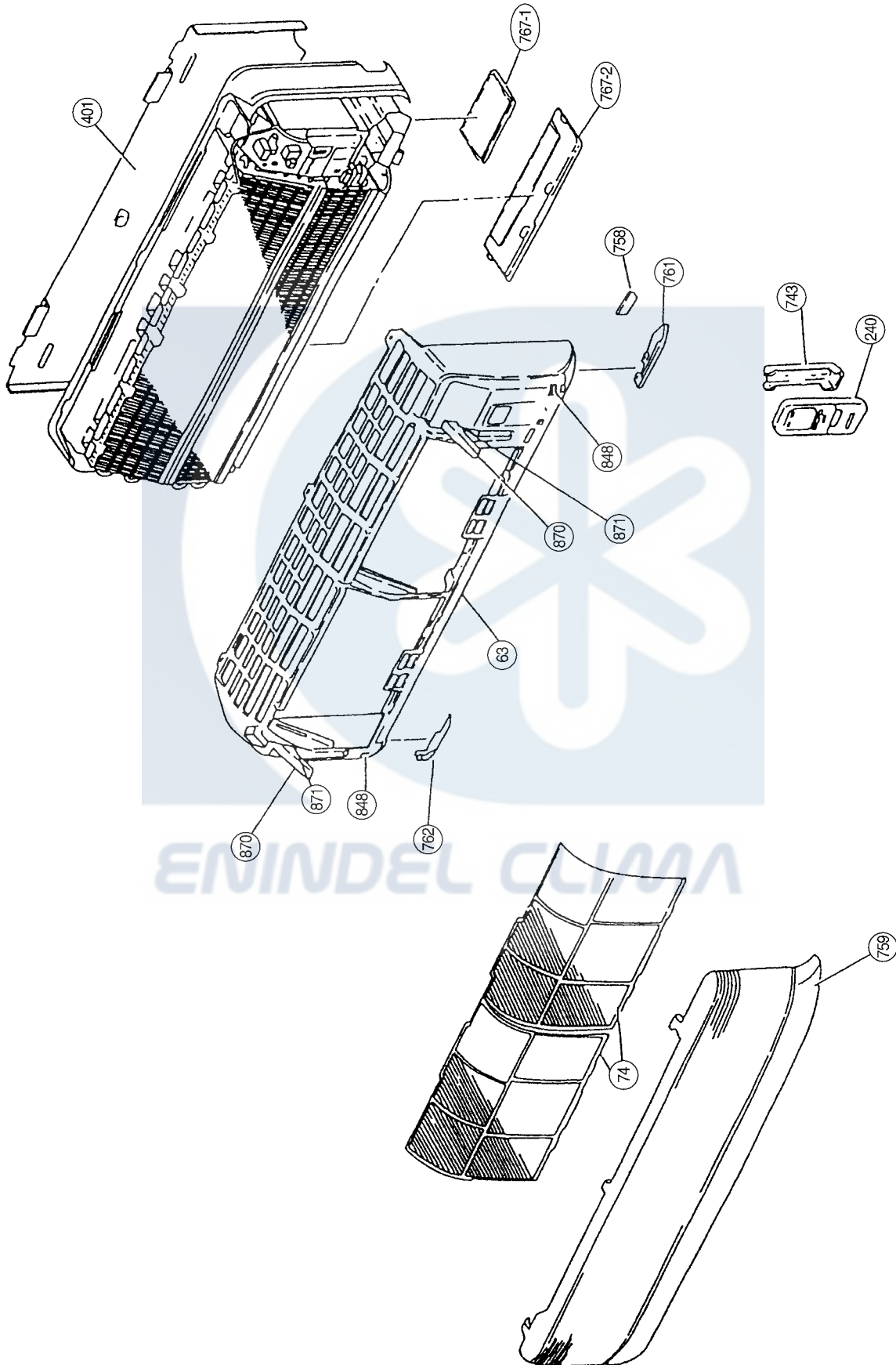

Models : ASG17FSBQ  
ASG17USBQ  
ASG17FSCQ  
ASG17USCQ

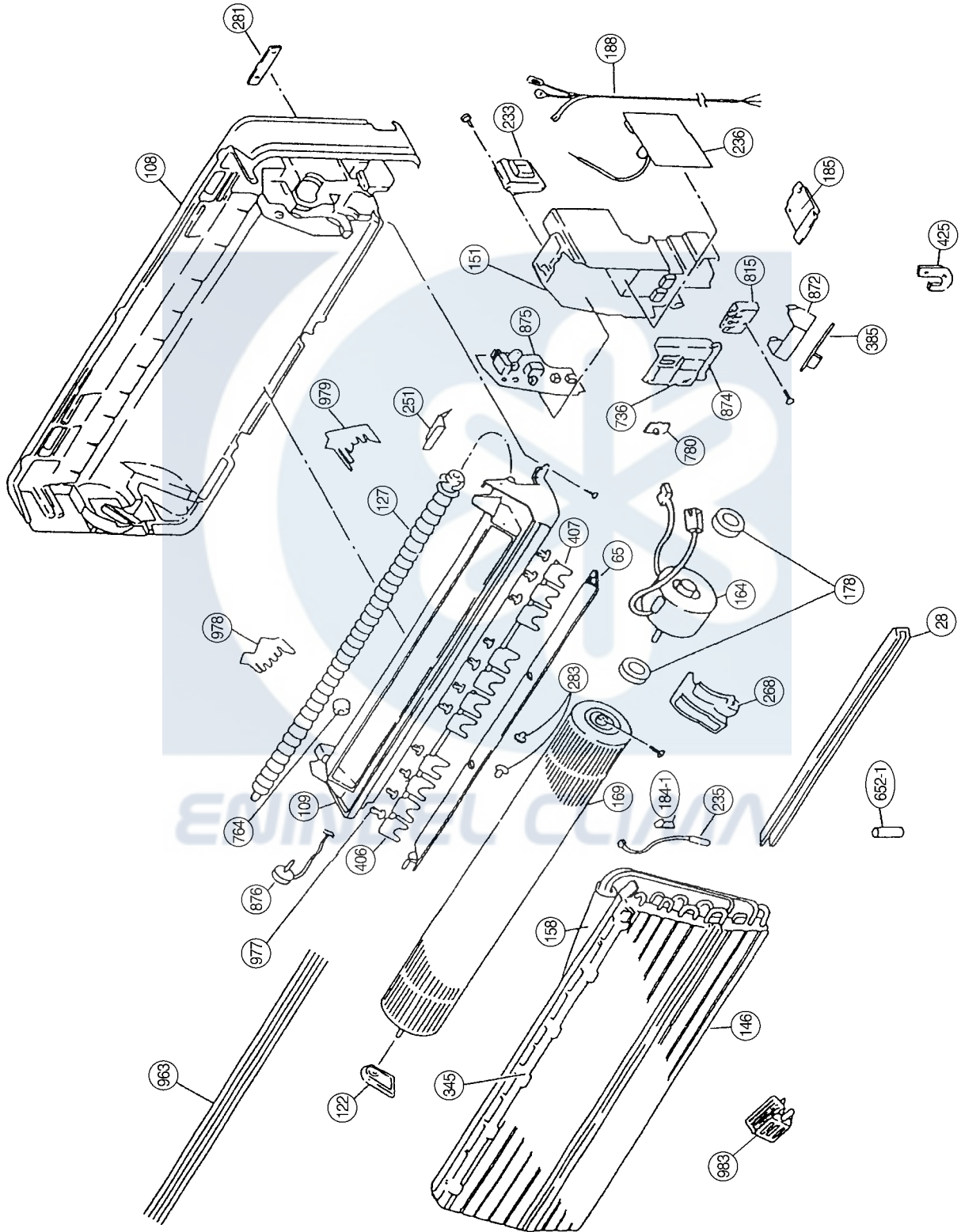

Models : AOG17FNBK  
AOG17UNBK  
AOG17FNBN  
AOG17UNBN

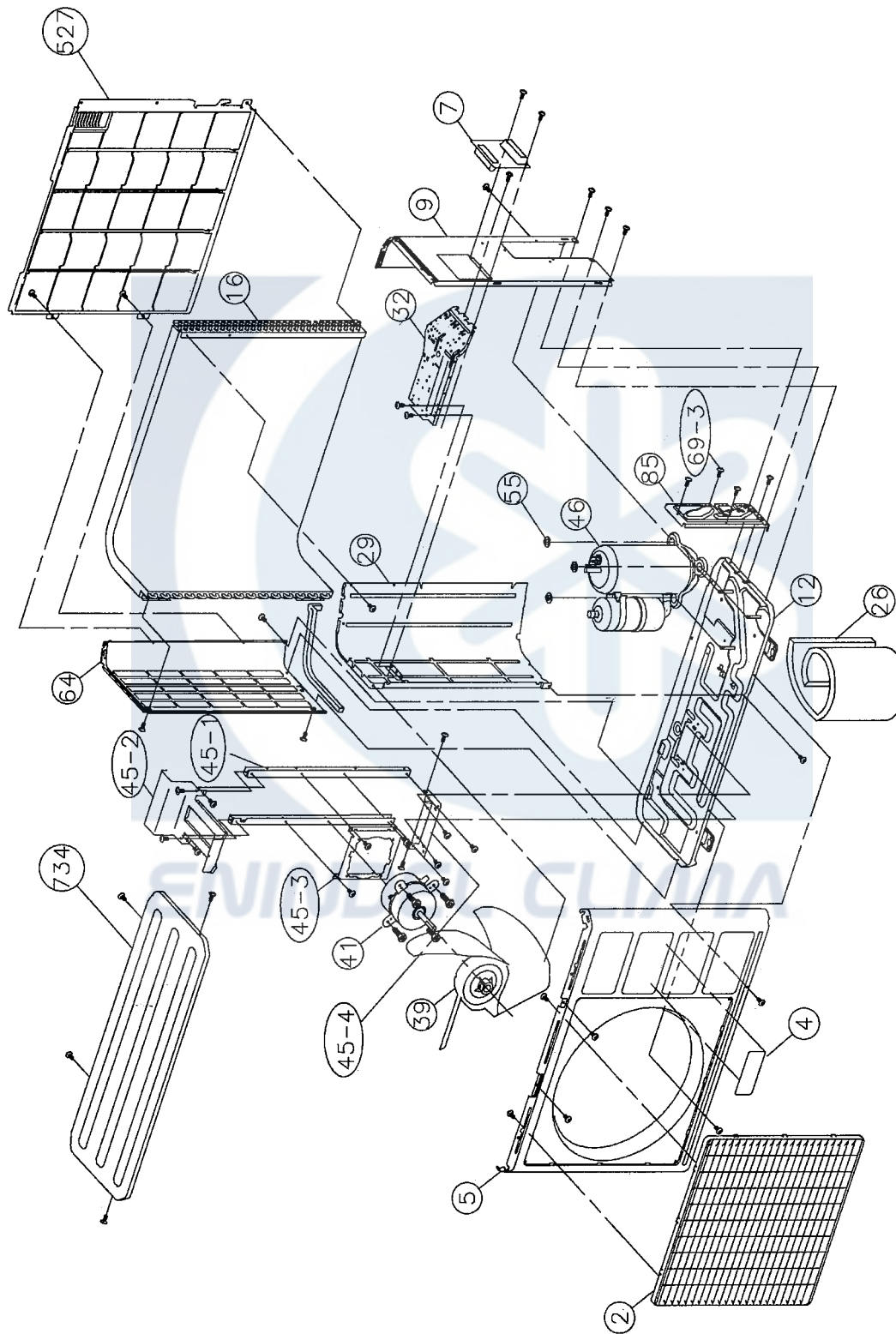

Models : AOG17FNBK  
AOG17UNBK  
AOG17FNBN  
AOG17UNBN

---

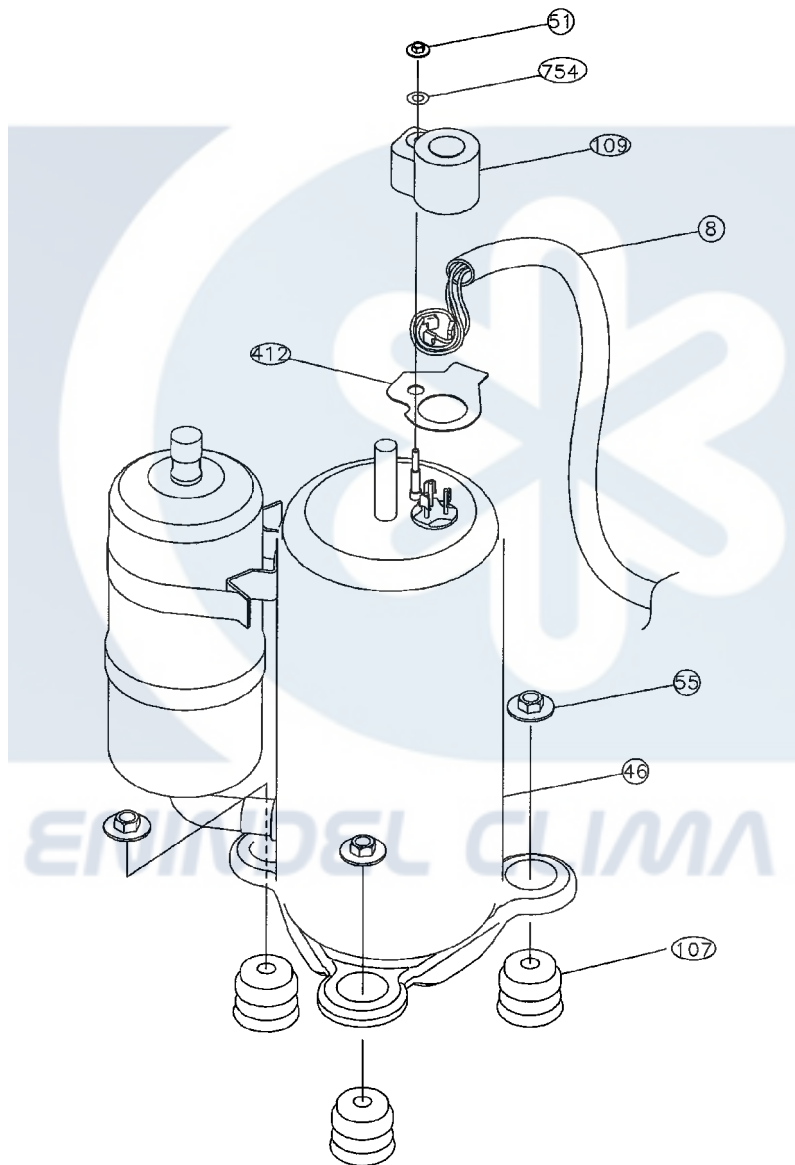

Models : AOG17FNBK  
AOG17FNBN

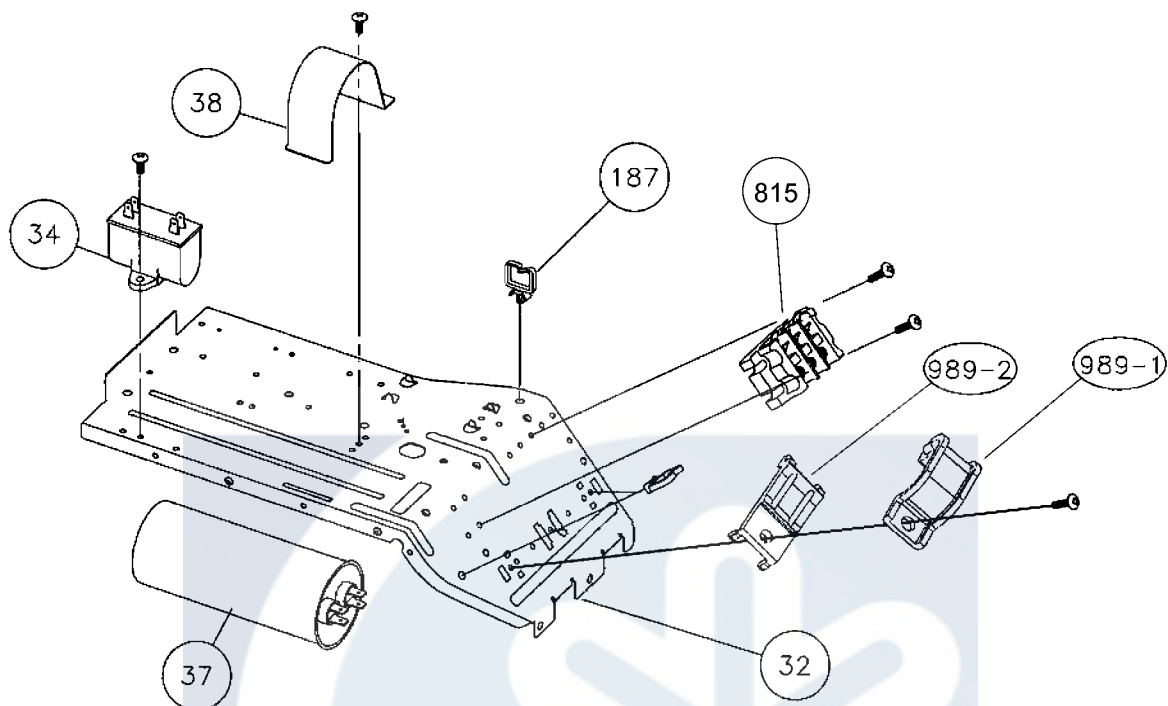

Model : AOG17UNBK  
AOG17UNBN

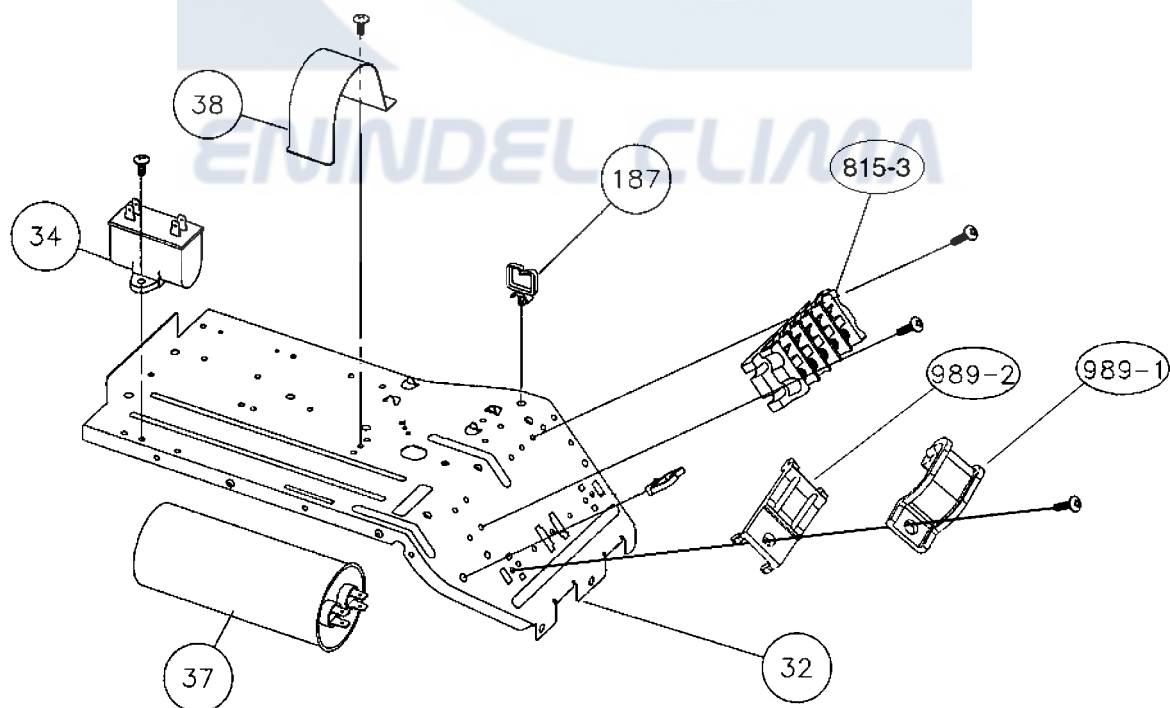

Model : AOG17FNBK  
AOG17FNBN

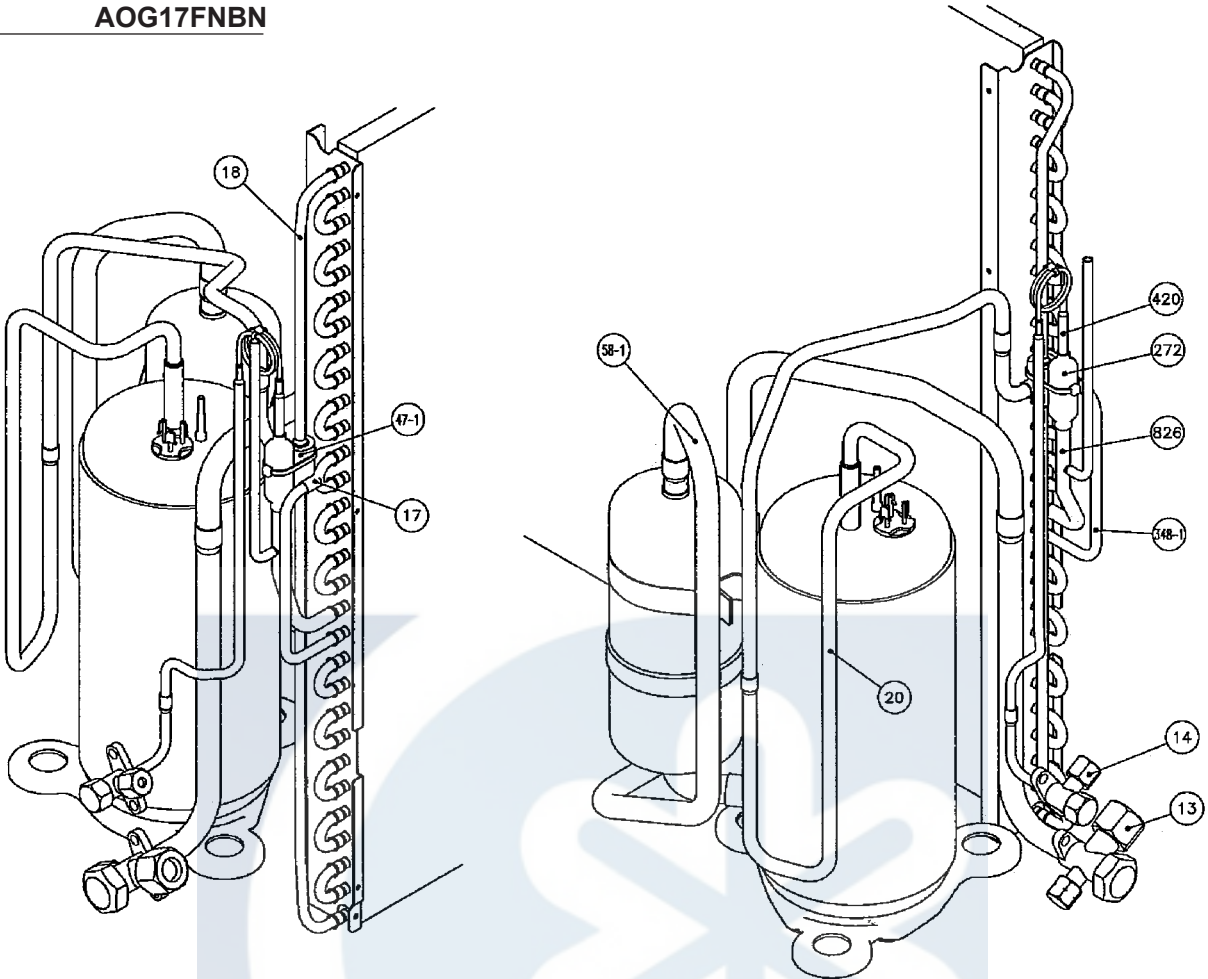

Model : AOG17UNBK  
AOG17UNBN

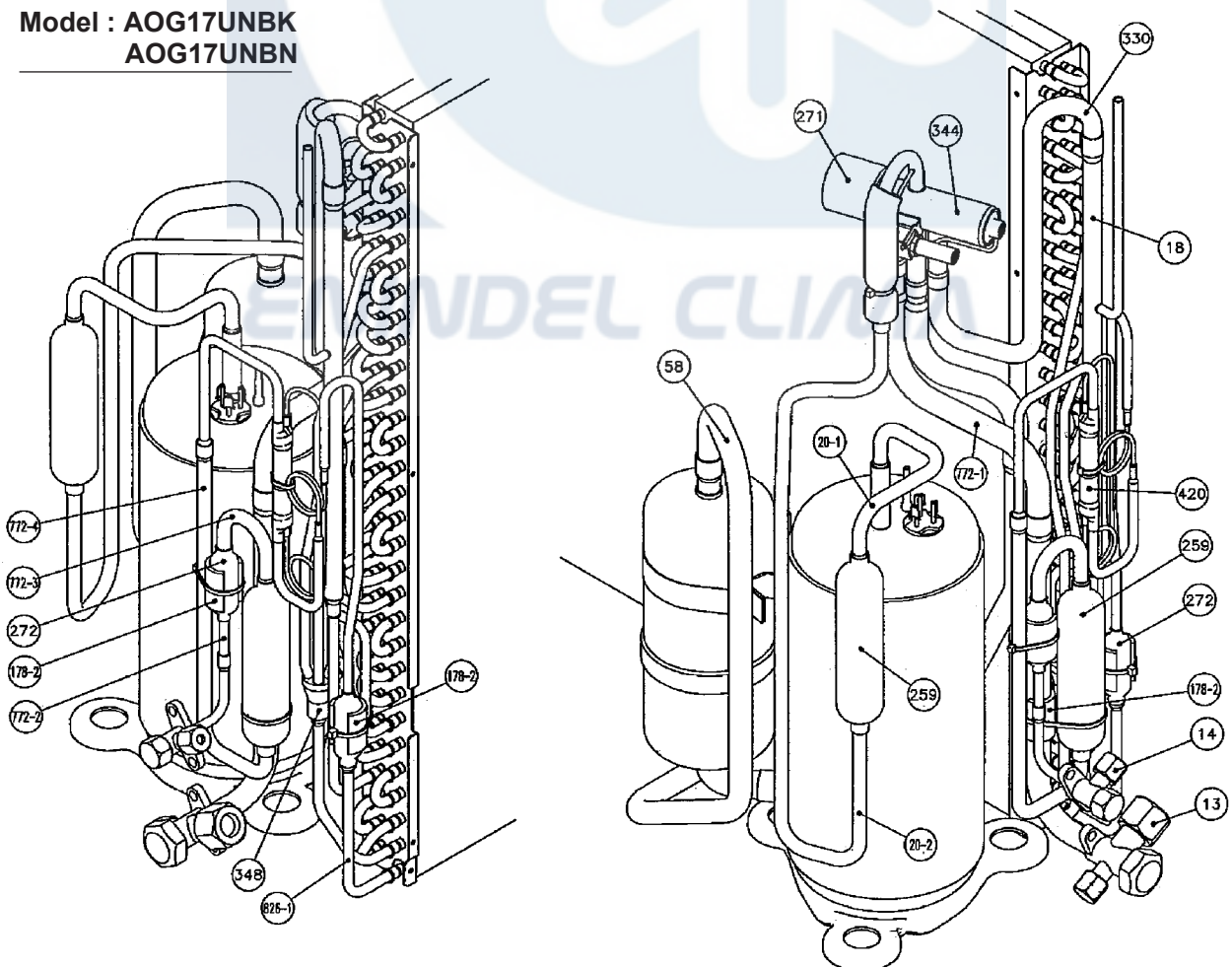

# PARTS LIST

## INDOOR UNIT

Ref. No.	Description	Part No.		Ord. Q'ty
		ASG17FSBQ ASG17FSCQ	ASG17USBQ ASG17USCQ	
28	Air Seal	9304111016	9304111016	
63	Front Panel Assy	9354645196	9354645196	
65	Louver Assy	9354646056	9354646056	
74	Filter	9304097013	9304097013	
108	Base	9304107033	9304107033	
109	Casing	9304108016	9304108016	
122	Bearing-B Assy	9304470007	9304470007	
127	Drain Hose Assy	9368754013	9368754013	
146	Evaporator Assy	9363335002	9363335002	
151	Control Box	9304092001	9304092001	
158	Connecting Pipe Assy	9363632002	9363632002	
164	Fan Motor	9600432013	9600432013	
169	Cross-flow Fan Assy	9306327002	9306327002	
178	Motor Cushion-G	9304669005	9304669005	
184-1	Thermostat Spring-A	313728262708	313728262708	
185	Wire Clamp	9356959000	9356959000	
188	Power Cord Assy	9906072018	9906072018	
233	Power Transformer	9701803026	9701803026	
235	Thermistor Assy-Pipe	9702325015	9702325015	
236	Controller PCB Assy	9704341044	9704341204	
240	Remote Control Unit	9356602029	9356602036	
251	Hose Clamp	9304077008	9304077008	
268	Motor Cover-B	9304231004	9304231004	
281	Clamp Metal (Pipe)	9304242000	9304242000	
283	Bushing-A	9303529010	9303529010	
345	Filter Guide	9304110019	9304110019	
385	Indicator PCB Assy	9701119219	9701119219	
401	Wall Hook Bracket	9304093008	9304093008	
406	Louver-L Assy	9354644014	9354644014	
407	Louver-R Assy	9354643017	9354643017	
425	Earth Terminal	9357852003	9357852003	
652-1	Thermistor Holder Pipe	313714262805	313714262805	
736	Operation Panel	9354230002	9354230002	
743	Remote Control Unit Holder Case	9305642014	9305642014	
758	Decoration Plate-A	9354223011	9354223011	
759	Intake Grille-B (GENERAL)	9357856025	9357856025	
761	Side Cover-R	9303518069	9303518069	
762	Side Cover-L	9303520123	9303520123	
764	Drain Cap Assy	9304150008	9304150008	
767-1	Bottom Cover-A	9303536056	9303536056	
767-2	Bottom Cover-B	9303537053	9303537053	
780	Key Top (Slide Switch)	9303526002	9303526002	
815	Terminal-2P	9701955022	-----	
815-3	Terminal-4P	-----	9701955039	
848	Catcher	9306545000	9306545000	
870	Arm	9303525005	9303525005	
871	Arm Spring	9304377009	9304377009	
872	Indicator Case	9303631003	9303631003	
874	Control Box Cover	9304094005	9304094005	
875	Power Supply PCB Assy	9702451073	9702451066	
876	Step Motor	9304535003	9304535003	
963	Fan Guard	9356881011	9356881011	
977	Louver Clip, Plastic	9356880014	9356880014	
978	Wire Bracket-L	9356878011	9356878011	
979	Wire Bracket-R	9356877014	9356877014	
983	Thermostat Protective Cover	9356882001	9356882001	

## OUTDOOR UNIT









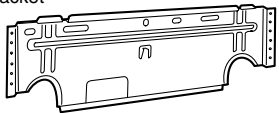
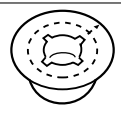

Ref. No.	Description	Part No.	Ord. Q'ty
		AOG17FNBK AOG17FNBN	
2	Fan Guard	9371187013	
4	Emblem-Rear	9372171011	
5	Front Panel Ptd	9371924014	
7	Connector Cover (Cabinet)	9366398004	
8	Wire Assy (Comp)	9372334010	
9	Side Panel R Ptd	9371927015	
12	Base Assy, Ptd	9371920054	
13-1	3-Way Valve Assy	9372205112	
13-2	2-Way Valve Assy	9372204016	
16	Condenser Assy	9372181041	
26	Compressor Cover	9372327012	
29	Separate Wall	9371933016	
32	Control Box	9371935010	
34	Capacitor, Plastic	9900130022	
37	Running Capacitor	9703107122	
38	Capacitor Clamp Metal	9351770013	
39	Propeller Fan Assy	9366378013	
41	Motor Induct	9601671022	
45-1	Motor Bracket	9371929019	
45-2	Motor Bracket-Top	9371931012	
45-3	Motor Bracket Center	9371930015	
45-4	Motor Bracket Bottom	9371932019	
46	Compressor Assy	9372558027	
47-1	Rubber (Discharge Pipe)	313194159807	
51	Special Nut M5	9300301015	
55	Special Nut M8	9355091008	
64	Side Panel L Ptd	9371926018	
69-3	Bolt, Hex. Socket	301210060360	
85	Valve Plate Ptd	9371928012	
107	Rubber Seat-A	9351049010	
109	Terminal Cover (Comp)	9371511016	
187	Clip (Cable)	9352715006	
272	Strainer	9369287008	
412	Cover Gasket (Comp.)	9371512013	
527	Protectiive Net	9371934013	
734	Top Plate	9371925011	
735-3	Capillary Assy	9372197066	
754	Terminal Gask. Washer	9351053017	
815	Terminal-3P	9900203016	
982-1	Cord Clamp	9356857009	
982-2	Cord Clamp-C	9359677000	

Ref. No.	Description	Part No.	Ord. Q'ty
		AOG17UNBK AOG17UNBN	
2	Fan Guard	9371187013	
4	Emblem-Rear	9372171011	
5	Front Panel Ptd	9371924014	
7	Connector Cover (Cabinet)	9366398004	
8	Wire Assy (Comp)	9372334010	
9	Side Panel R Ptd	9371927015	
12	Base Assy, Ptd	9371920054	
13-1	3-Way Valve Assy	9372205112	
13-2	2-Way Valve Assy	9372204016	
16	Condenser Assy	9372181034	
26	Compressor Cover A	9372327012	
29	Separate Wall	9371933016	
32	Control Box	9371935010	
34	Capacitor, Plastic	9900130022	
37	Running Capacitor	9703107122	
38	Capacitor Clamp Metal	9351770013	
39	Propeller Fan Assy	9366378013	
41	Motor Induct	9601671022	
45-1	Motor Bracket	9371929019	
45-2	Motor Bracket-Top	9371931012	
45-3	Motor Bracket Ctr	9371930015	
45-4	Motor Bracket Bottom	9371932019	
46	Compressor Assy	9372558027	
51	Special Nut M5	9300301015	
55	Special Nut M8	9355091008	
64	Side Panel L Ptd	9371926018	
69-3	Bolt, Hex. Socket	301210060360	
85	Valve Plate Ptd	9371928012	
107	Rubber Seat-A	9351049010	
109	Terminal Cover (Comp)	9371511016	
187	Clip (Cable)	9352715006	
199	Br Sheet	9363708059	
259	Muffler	9372369012	
271	4-Way Valve Rubber	313728251908	
272	Strainer	9369287008	
343	Solenoid	9900165017	
344	4-Way Valve	9970036019	
412	Cover Gasket (Comp.)	9371512013	
527	Protectiive Net	9371934013	
734	Top Panel	9371925011	
735-3	Capillary Assy	9372197042	
754	Terminal Gask. Washer	9351053017	
815-3	Terminal-5P	9900203023	
982-1	Cord Clamp	9356857009	
982-2	Cord Clamp-C	9359677000	



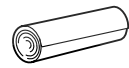

# STANDARD ACCESSORIES

## INDOOR UNIT ACCESSORIES

Name and Shape	Part No.	
	ASG17FSBQ ASG17FSCQ	ASG17USBQ ASG17USCQ
Wall hook bracket 	9304093008	9304093008
Wall cap 	313714296205	313714296205
Remote control unit 	9356602029 (AR-AB9)	9356602036 (AR-AB10)
Battery (penlight) 	0600185534	0600185534
Cable mark 	----	9301385007
Tapping screw (Big) ( $\phi 4 \times 20$ ) 	301141164200	301141164200
Tapping screw (Small) ( $\phi 3 \times 12$ ) 	0700019036	0700019036
Flange screw ( $\phi 4 \times 10$ ) 	9305114009	9305114009
Remote control unit holder case 	9305642014	9305642014
Cloth tape 	9308117007	9308117007
Seal-A 	9304536000	9304536000

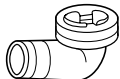
## OUTDOOR UNIT ACCESSORIES

Name and Shape	Part No.	
	AOG17FNBK AOG17FNBN	AOG17UNBK AOG17UNBN
Drain pipe (Including drain packing) 	----	9303029015
Drain cap 	----	313166024302



0401G2513

[WWW.ENINDEL.COM](http://WWW.ENINDEL.COM)