



SPLIT TYPE
AIR CONDITIONER
DUCT TYPE (50Hz)

SERVICE MANUAL

Indoor unit	Outdoor unit
ARHG45LHTA	AOHG45LATT
ARHG54LHTA	AOHG54LATT



ENINDEL CONTENTS

SPECIFICATIONS	1
DIMENSIONS.....	2
REFRIGERANT SYSTEM DIAGRAM... 4	4
CIRCUIT DIAGRAM.....	5
INDOOR PCB CIRCUIT DIAGRAM.....	6
OUTDOOR PCB CIRCUIT DIAGRAM... 7	7
ERROR DETECTION.....	14
PARTS (INDOOR UNIT).....	18
PARTS (OUTDOOR UNIT).....	20
ACCESSORIES.....	23

SPECIFICATIONS

ELECTRICAL DATA

TYPE		Cooling & Heating	
INDOOR UNIT		ARHG45LHTA	ARHG54LHTA
OUTDOOR UNIT		AOHG45LATT	AOHG54LATT
COOLING CAPACITY		12.5 kW	14.0 kW
HEATING CAPACITY		14.0 kW	16.0 kW
POWER SOURCE		400 V, 50 Hz, 3 phase, 4 W	
RUNNING CURRENT	Cooling	6.1 A	6.9 A
	Heating	5.5 A	6.5 A
INPUT WATTS	Cooling	4.06 kW	4.65 kW
	Heating	3.67 kW	4.37 kW
E.E.R.	Cooling	3.08 kW/kW	3.01 kW/kW
C.O.P.	Heating	3.81 kW/kW	3.66 kW/kW
MOISTURE REMOVAL		1.5 L/hr	2.5 L/hr
AIRCIRCULATION INDOOR		3,350 m3/h	3,350 m3/h
AIRCIRCULATION OUTDOOR	Cooling	6,750 m3/h	6,900 m3/h
	Heating	6,200 m3/h	6,900 m3/h
MAXIMUM CURRENT		11.0 A	12.0 A

FAN MOTOR

INDOOR UNIT, Discrimination		MFA-60TTFS	
INDOOR UNIT	High	1,300 r.p.m.	
	Medium	1,150 r.p.m.	
	Low	1,000 r.p.m.	
OUTDOOR UNIT, Discrimination		MFE-54VVT	
OUTDOOR UNIT Cooling	Upper fan	850 r.p.m.	900 r.p.m.
	Lower fan	800 r.p.m.	800 r.p.m.
OUTDOOR UNIT Heating	Upper fan	780 r.p.m.	870 r.p.m.
	Lower fan	750 r.p.m.	840 r.p.m.

NOISE LEVEL

INDOOR UNIT	High	47 dB	
	Medium	43 dB	
	Low	40 dB	
OUTDOOR UNIT	Cooling	54 dB	55 dB
	Heating	54 dB	56 dB

COMPRESSOR AND REFRIGERANT

TYPE		Hermetic type, Inverter, 4 poles, 3 phase, DC motor, Twin Rotary	
DISCRIMINATION		DA422A3F-29ZAD	
WEIGHT (with oil)		23.0 kg	
REFRIGERANT TYPE		R410A	
PRECHARGED REFRIGERANT		3,450 g	
MAX PIPE HEIGHT		30 m	
FULL CHARGE	Pipe length	30 m	3,450 g
		45 m	4,200 g
		60 m	4,950 g
		75 m	5,700 g
ADDITIONAL CHARGE		50 g/m	

DIMENSIONS

INDOOR UNIT	H x W x D	400 x 1,050 x 500 mm
OUTDOOR UNIT	H x W x D	1,290 x 900 x 330 mm

WEIGHT

INDOOR UNIT	Shipping / Net	51 kg / 46 kg
OUTDOOR UNIT	Shipping / Net	113 kg / 104 kg

DIMENSIONS

INDOOR UNIT

(Unit : mm)

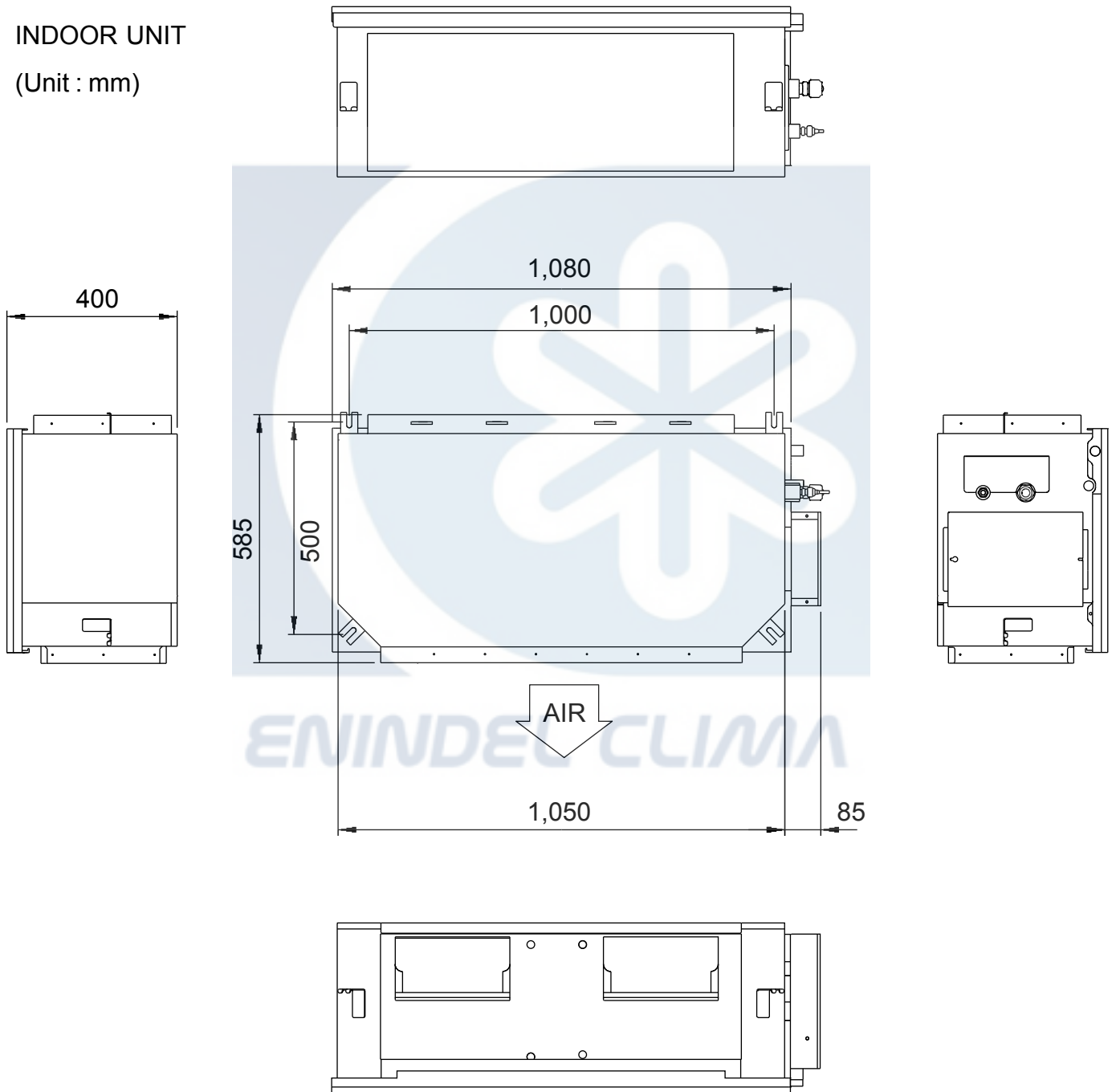

OUTDOOR UNIT
(unit : mm)

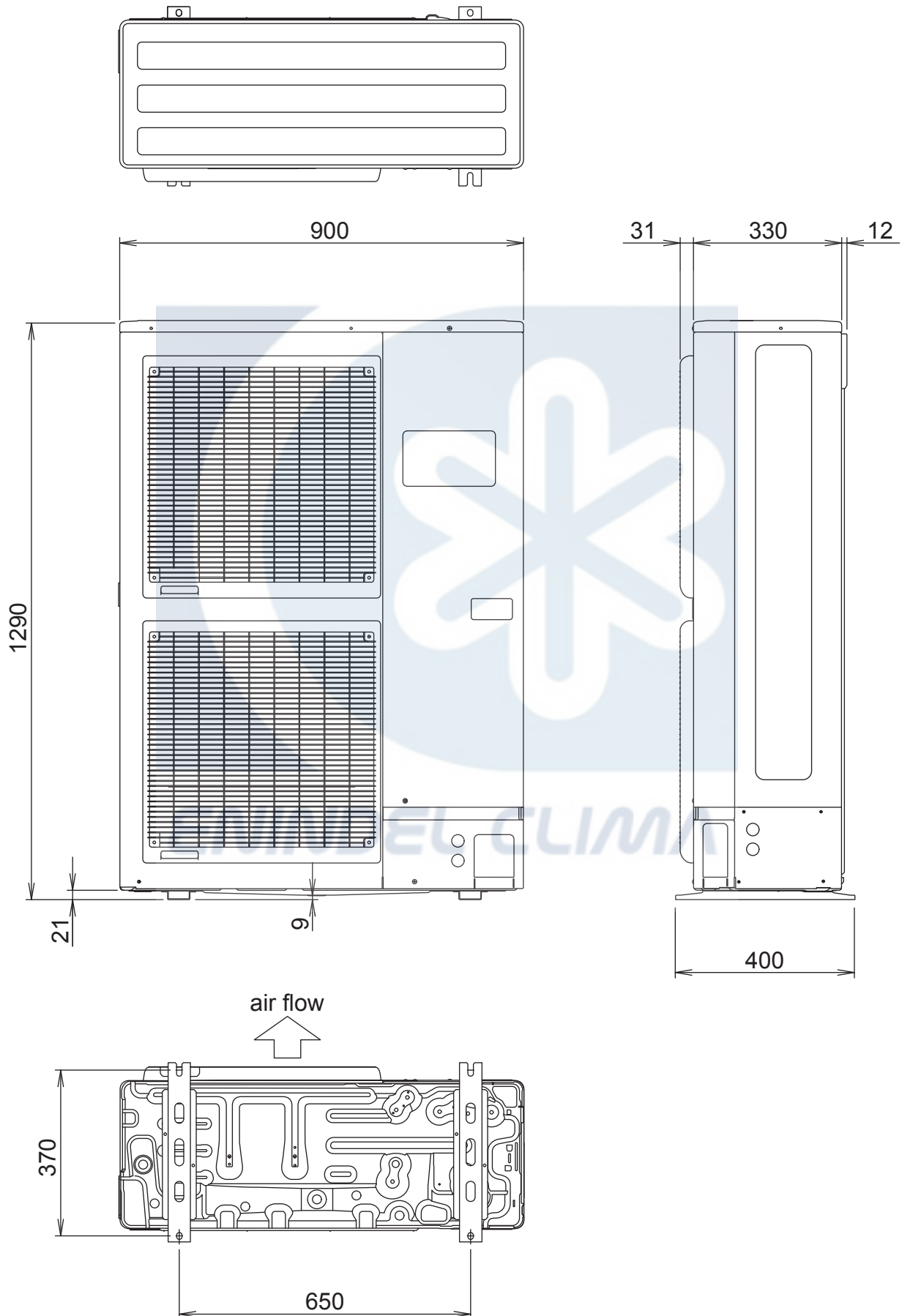

REFRIGERANT SYSTEM DIAGRAM

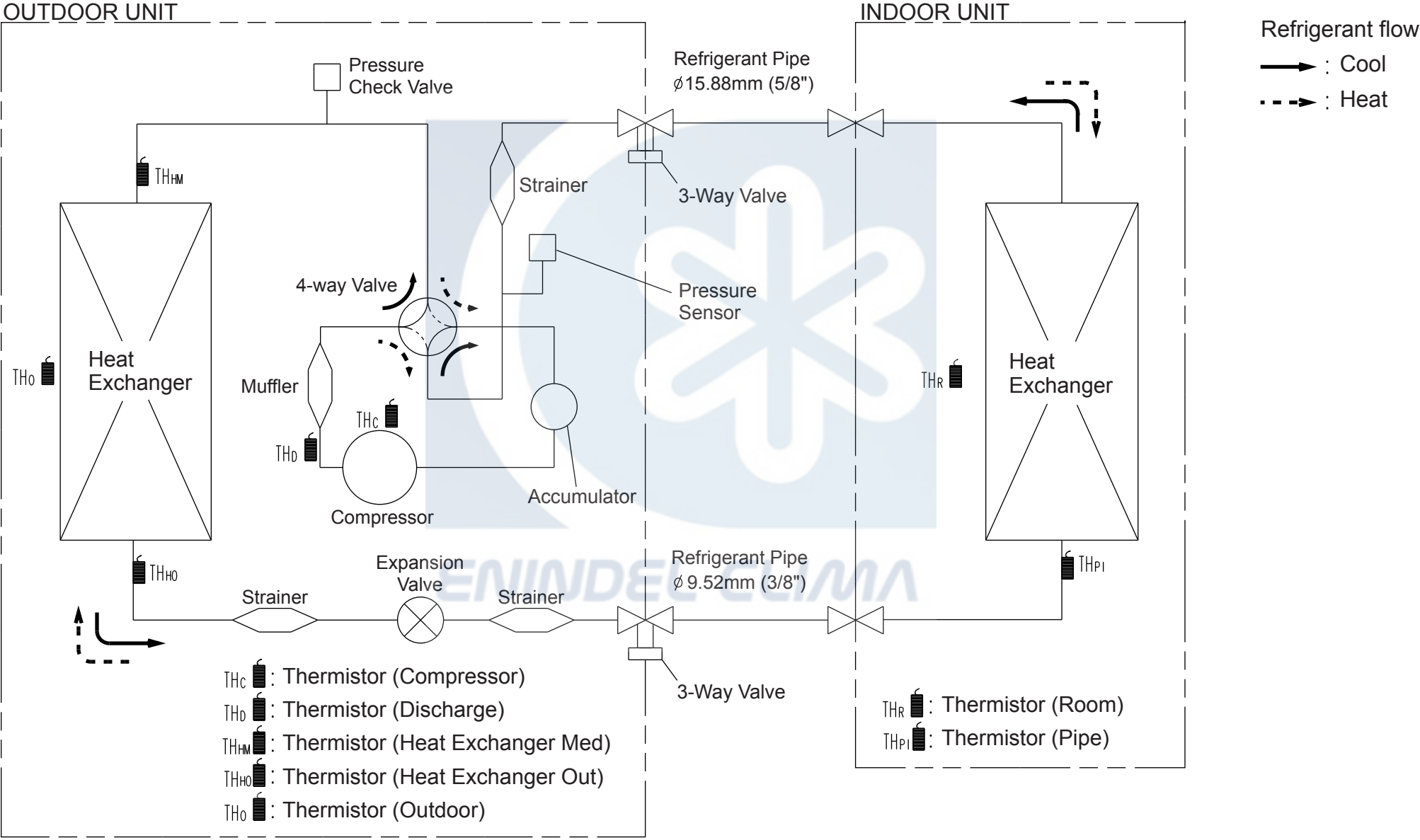

CIRCUIT DIAGRAM

INDOOR UNIT

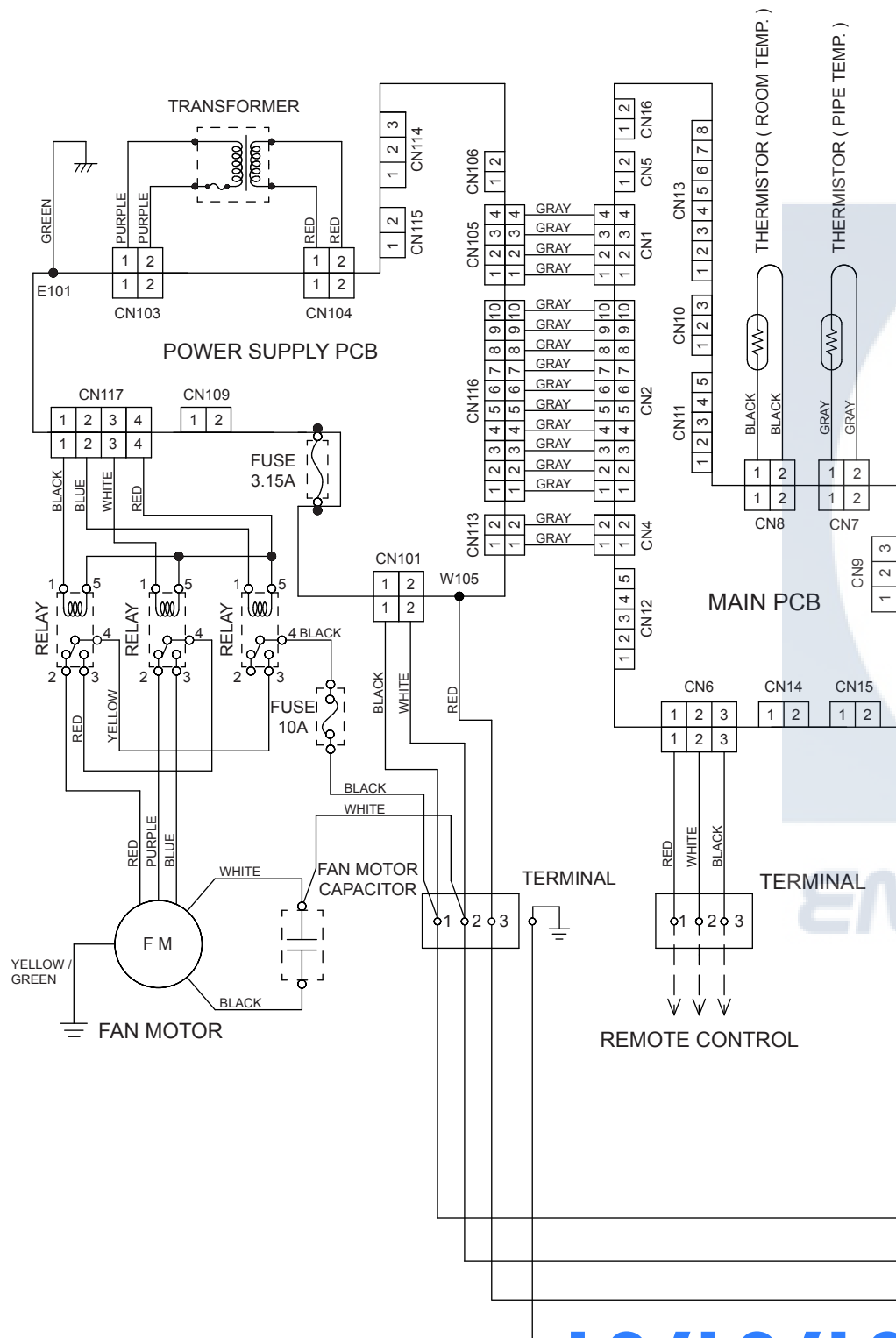

OUTDOOR UNIT

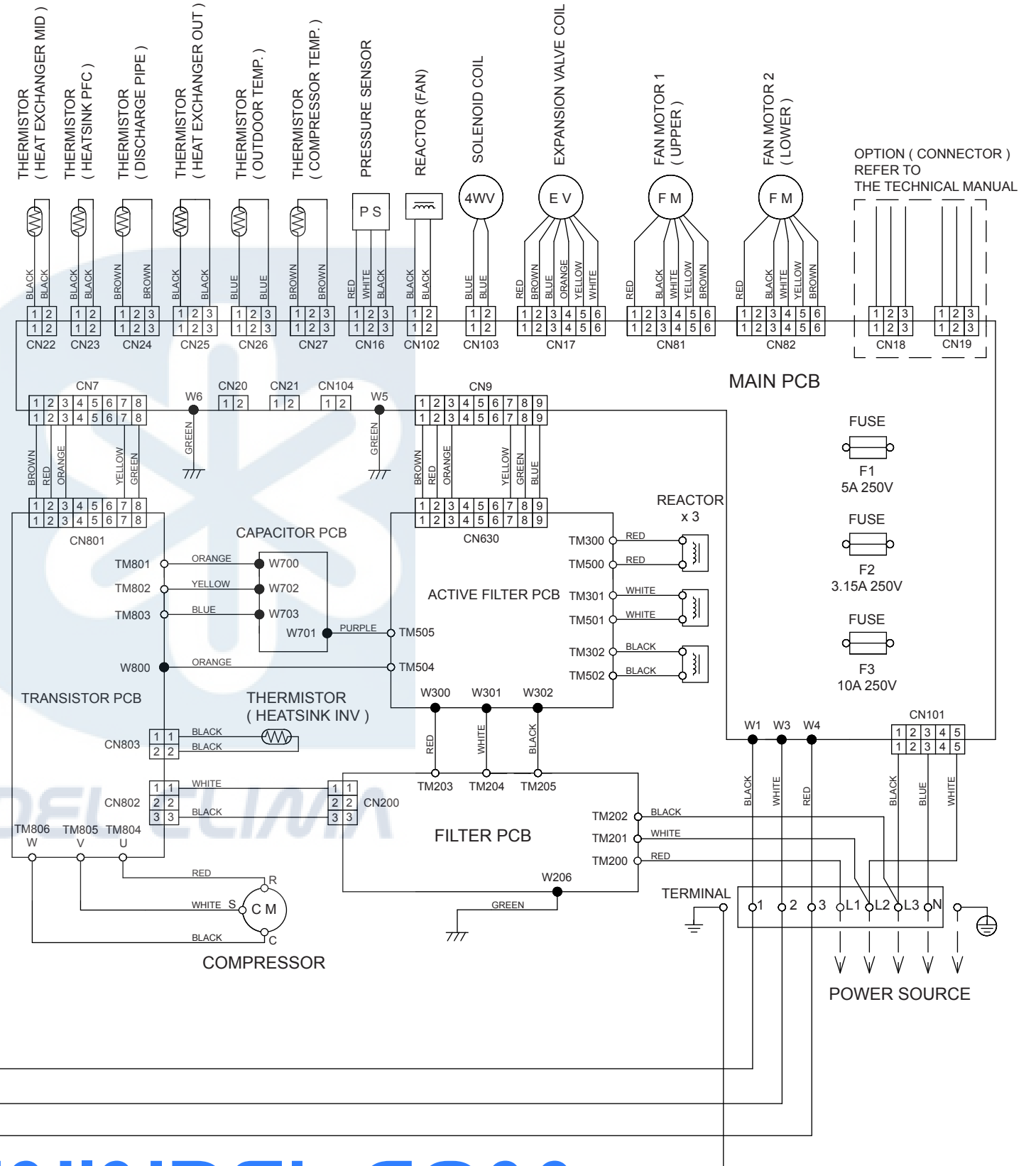

**POWER SUPPLY PCB
K04CW-1100HSE-P0**

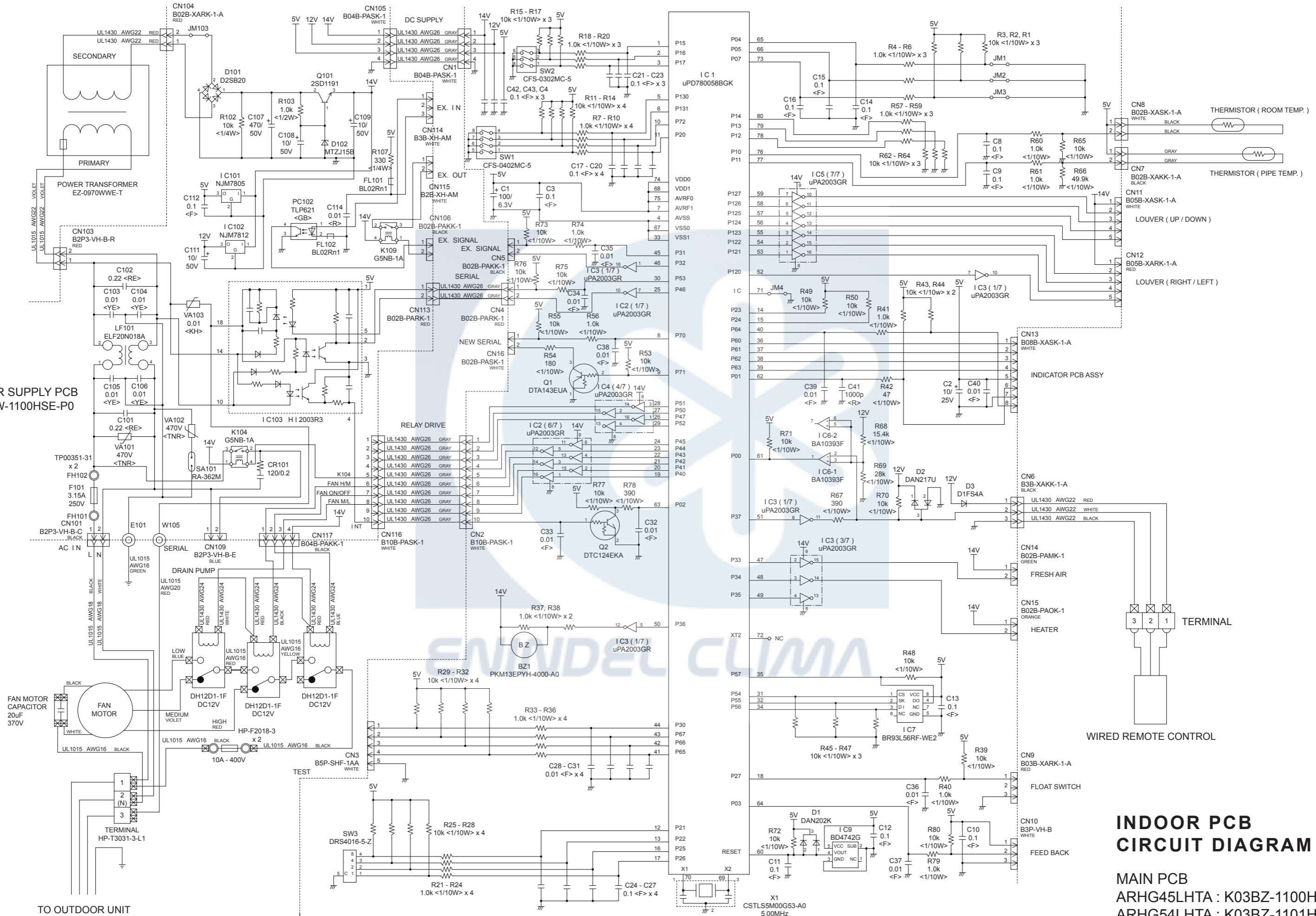

**INDOOR PCB
CIRCUIT DIAGRAM**

MAIN PCB
 ARHG45LHTA : K03BZ-1100HSE-C1
 ARHG54LHTA : K03BZ-1101HSE-C1

OUTDOOR PCB CIRCUIT DIAGRAM

INVERTER ASSEMBLY
AOHG45LATT : EZ-0111WHUE
AOHG54LATT : EZ-0111YHUE

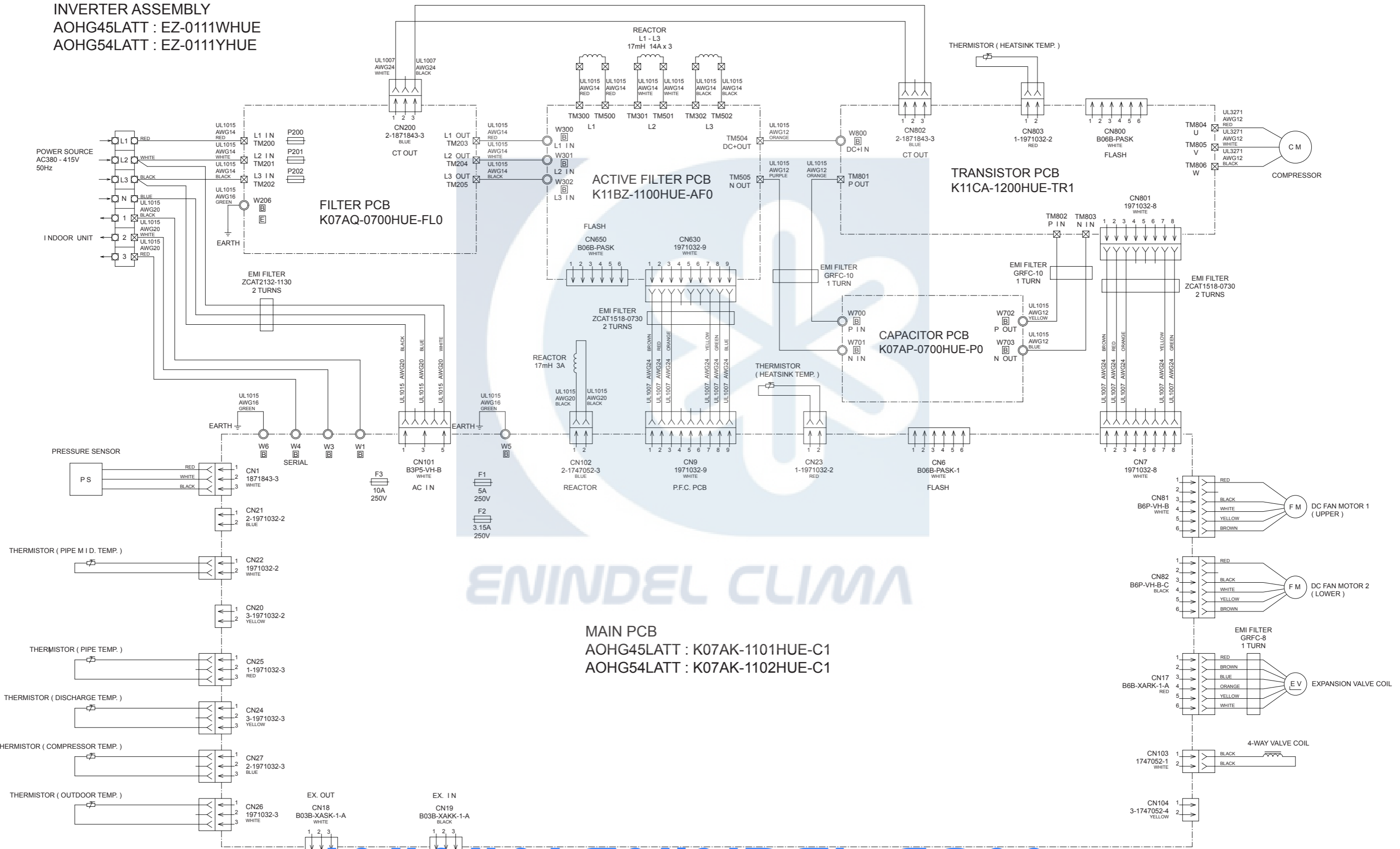

MAIN PCB
AOHG45LATT : K07AK-1101HUE-C1
AOHG54LATT : K07AK-1102HUE-C1

**OUTDOOR UNIT
MAIN PCB**
 AOHG45LATT : K07AK-1101HUE-C1
 AOHG54LATT : K07AK-1102HUE-C1

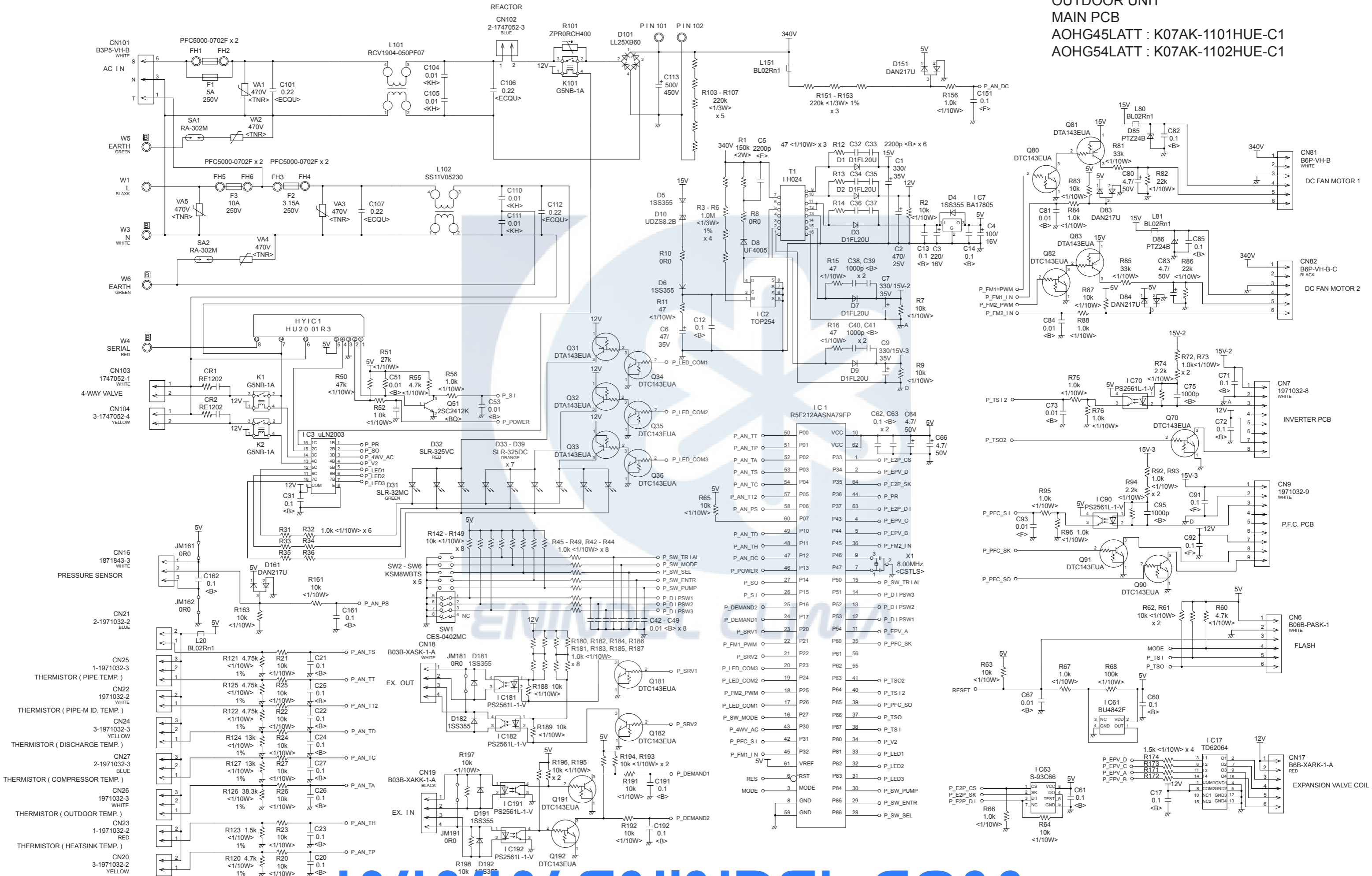

OUTDOOR UNIT
TRANSISTOR PCB
K11CA-1200HUE-TR1

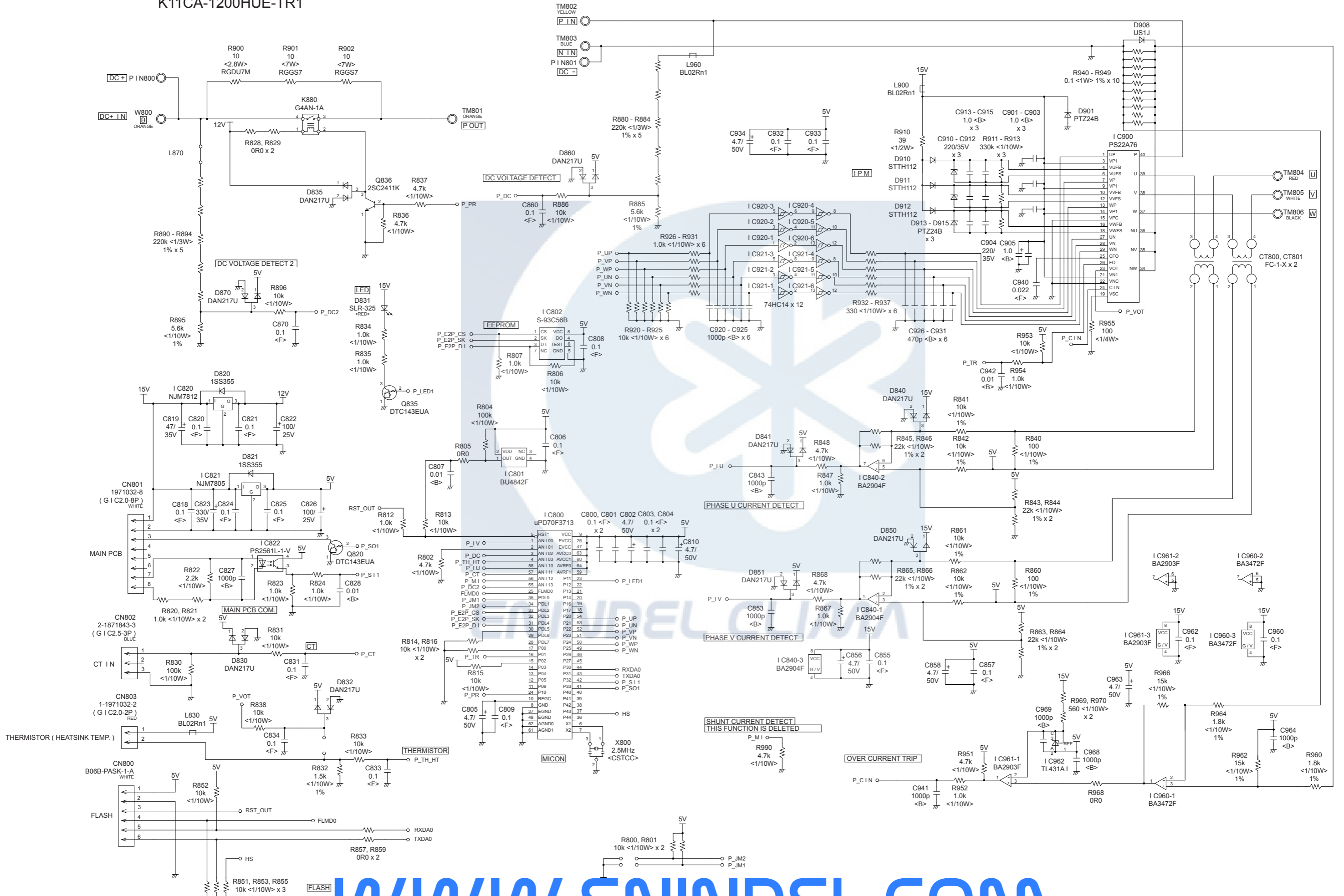

OUTDOOR UNIT
ACTIVE FILTER PCB - 1
K-11BZ-1100HUE-AF0

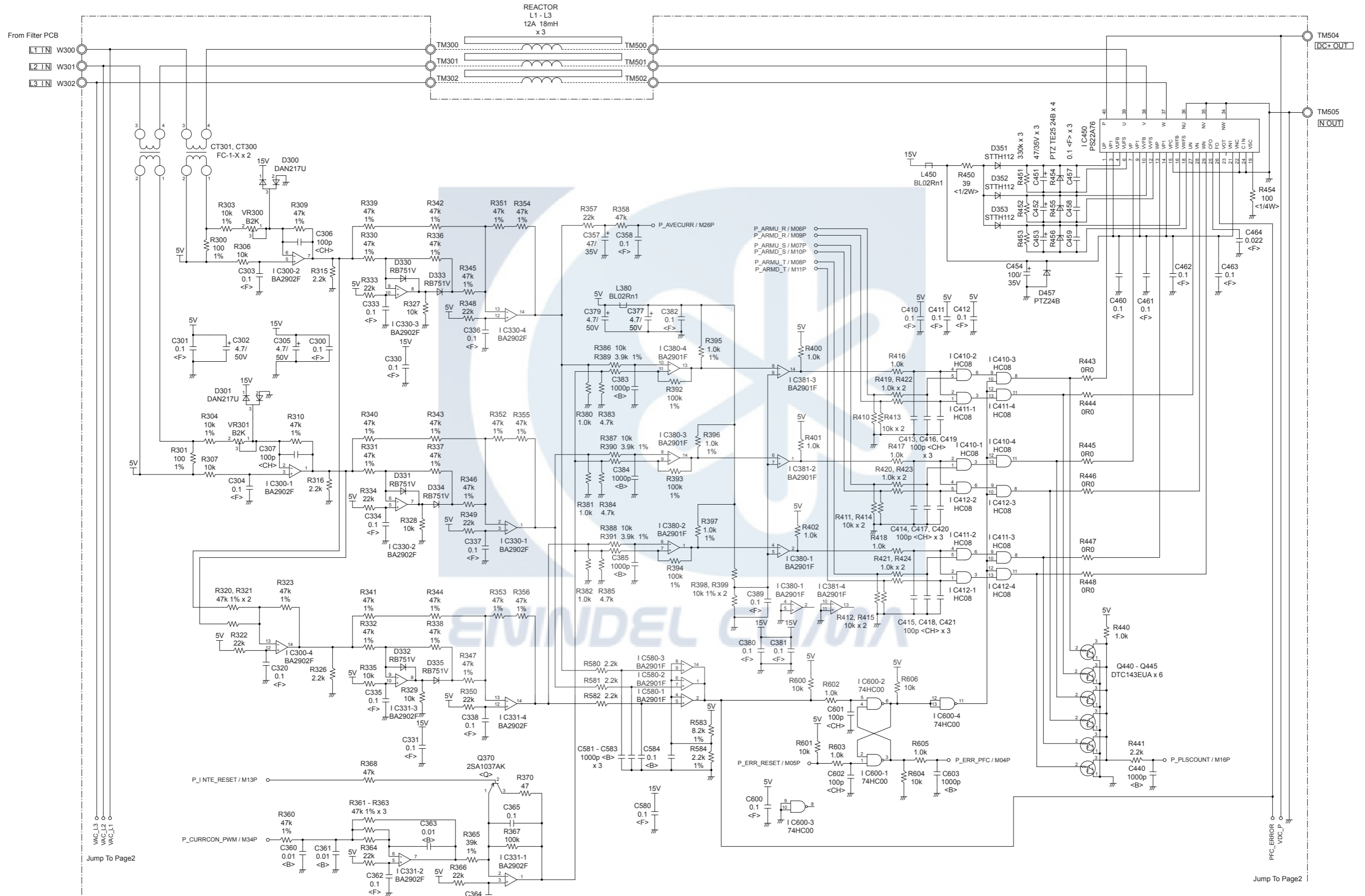

Jump To Page2

Jump To Page2

OUTDOOR UNIT
ACTIVE FILTER PCB - 2
K11BZ-1100HUE-AF0

Jump To Page1

Jump To Page1

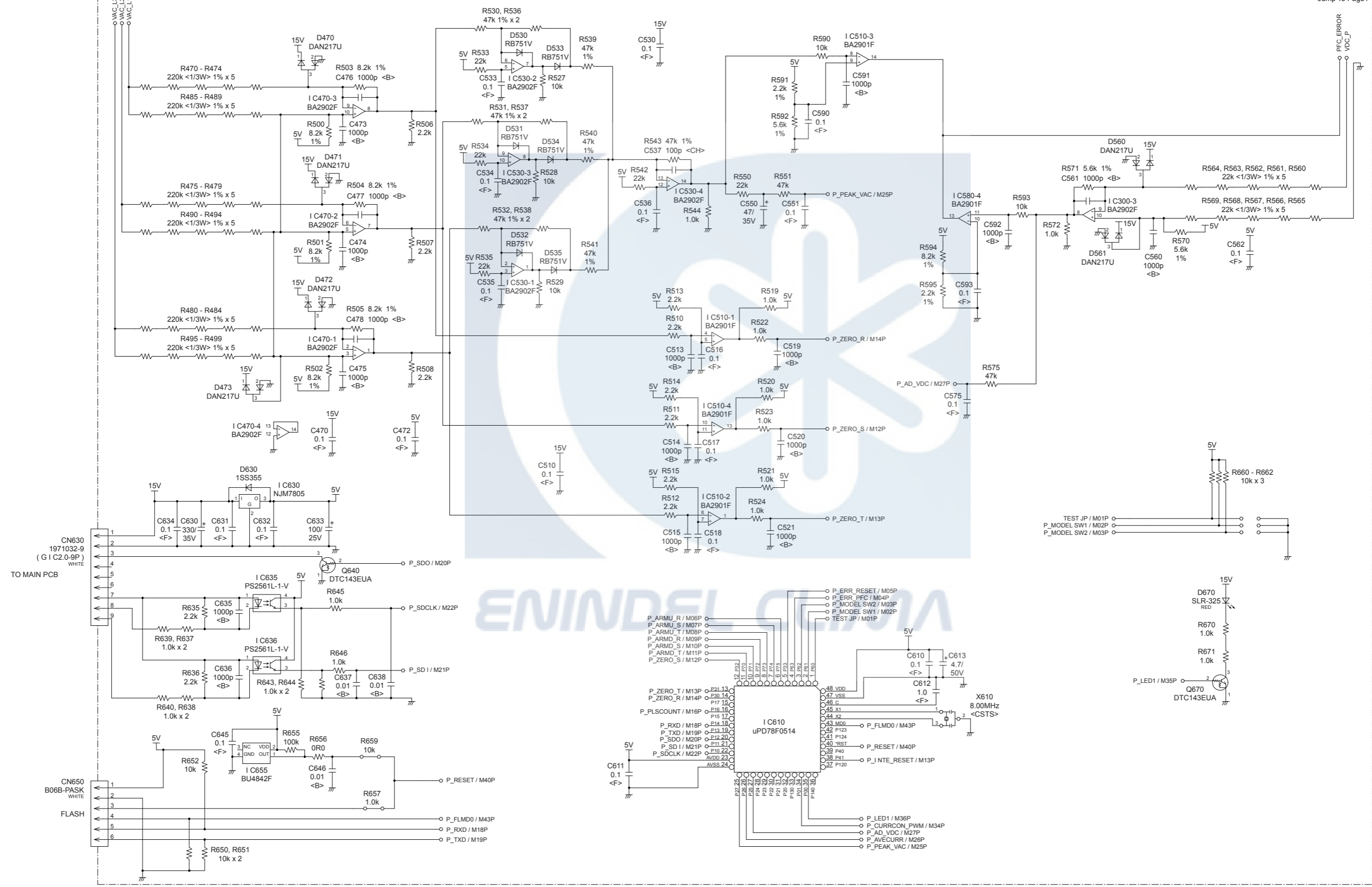

OUTDOOR UNIT FILTER PCB K07AQ-0700HUE-FL0

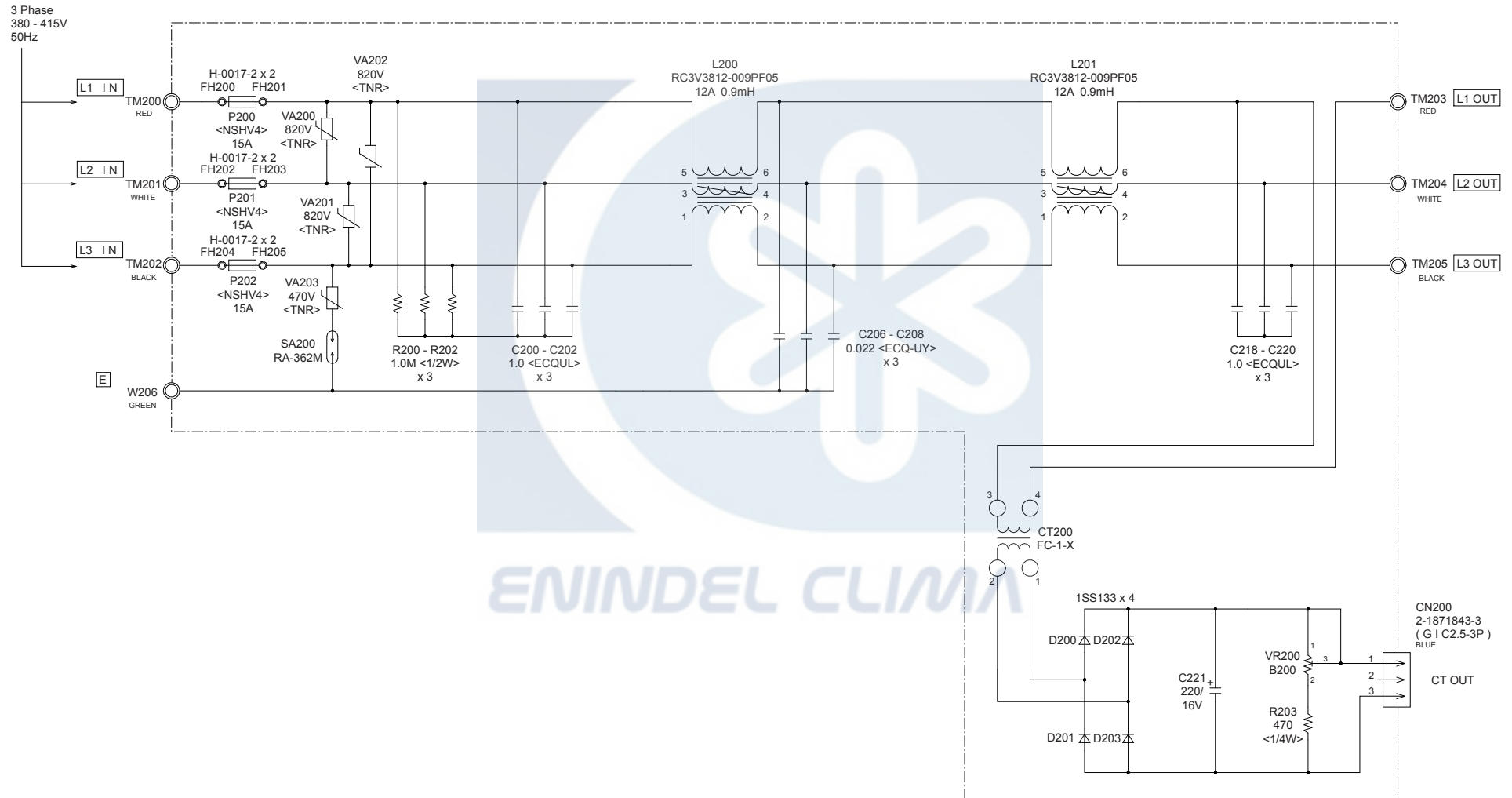

OUTDOOR UNIT
CAPACITOR PCB
K07AP-0700HUE-P0

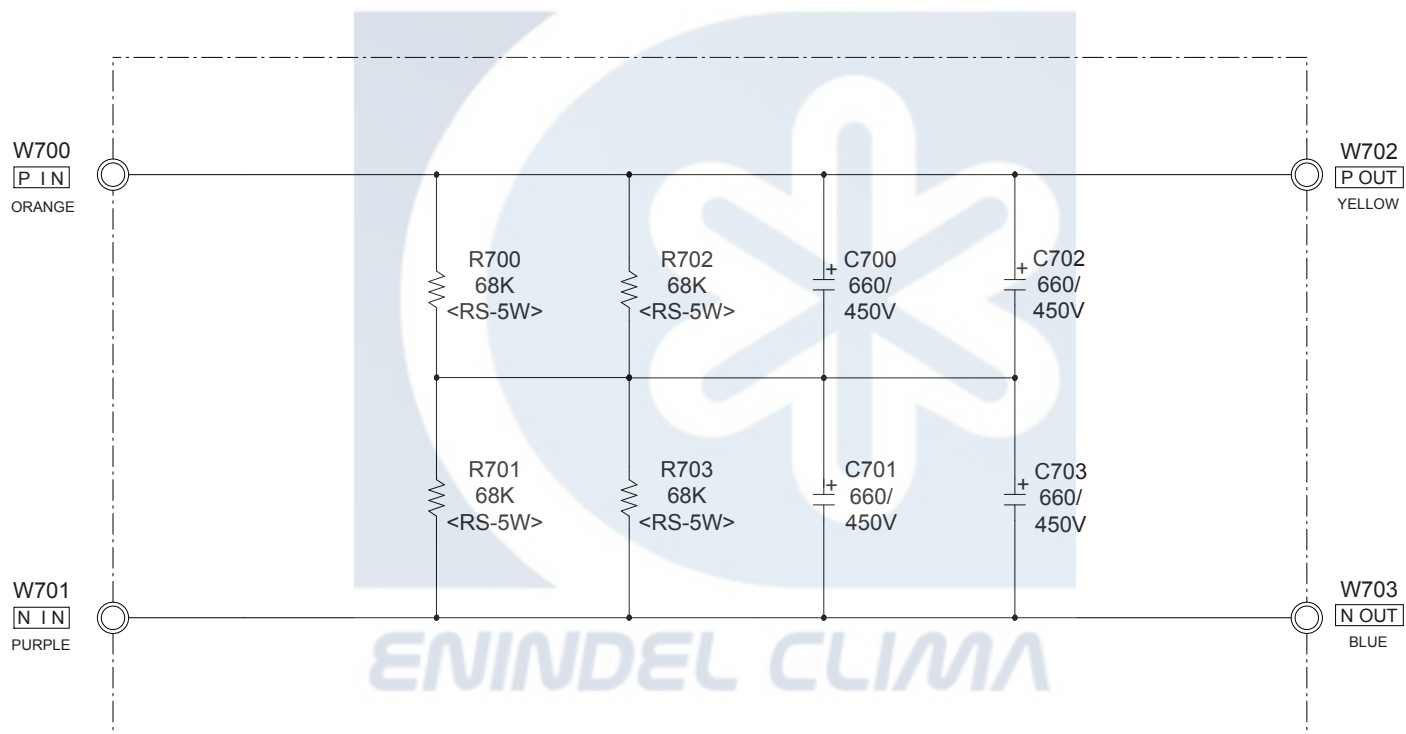

PARTS

INDOOR UNIT

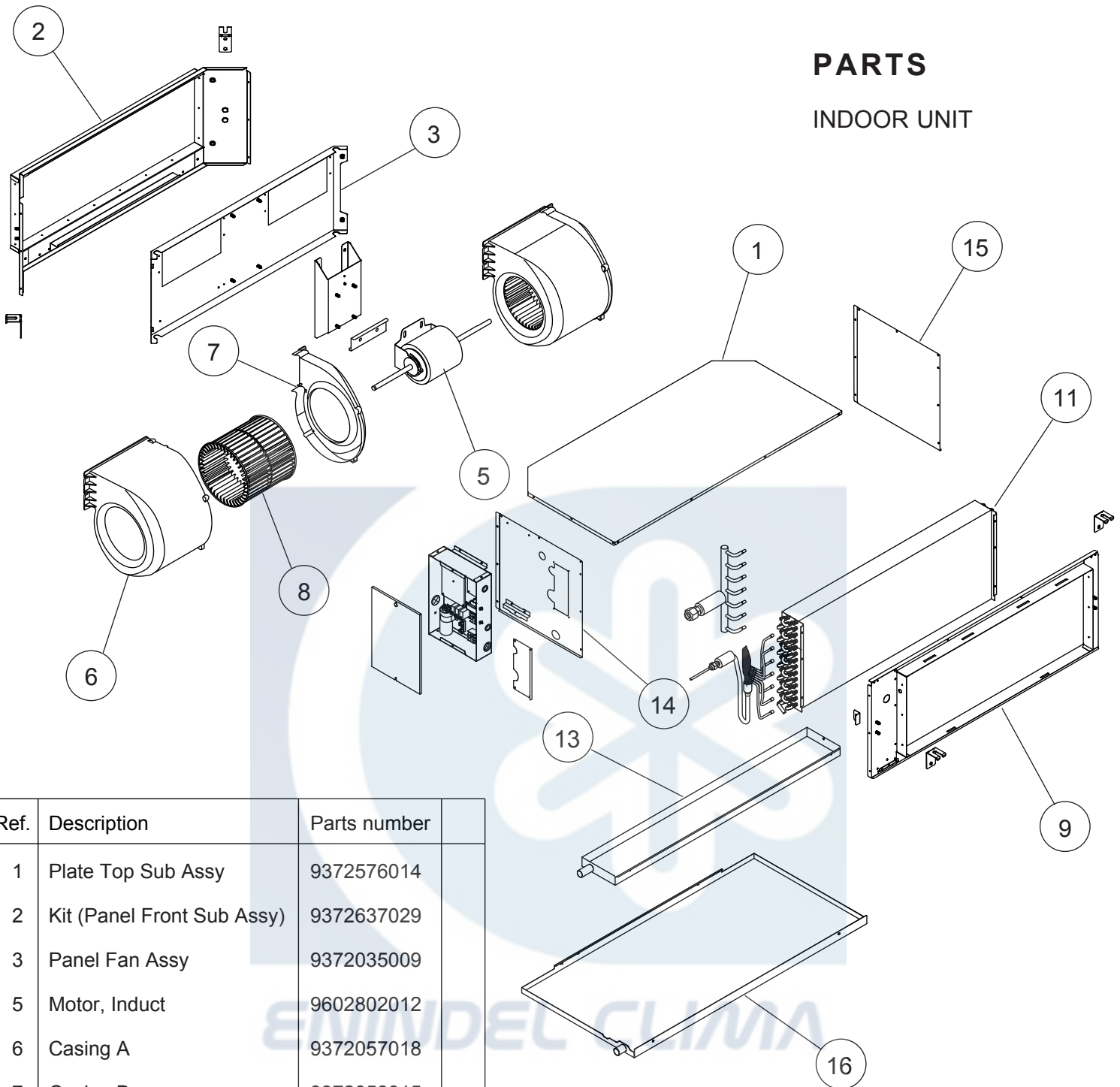

Ref.	Description	Parts number
1	Plate Top Sub Assy	9372576014
2	Kit (Panel Front Sub Assy)	9372637029
3	Panel Fan Assy	9372035009
5	Motor, Induct	9602802012
6	Casing A	9372057018
7	Casing B	9372058015
8	Sirocco Fan	9372059029
9	Kit (Panel Rear Sub Assy)	9372636022
10	Room Thermistor	9703299216
11	Evaporator Sub Assy	9372584057
12	Pipe Thermistor	9703297113
13	Drain Pan Assy	9372579015
14	Kit (Panel Right Sub Assy)	9372916025
15	Kit (Panel Left Sub Assy)	9372581018
16	Drain Pan S Sub Assy	9372582015

(Connector : white) (Connector : black)

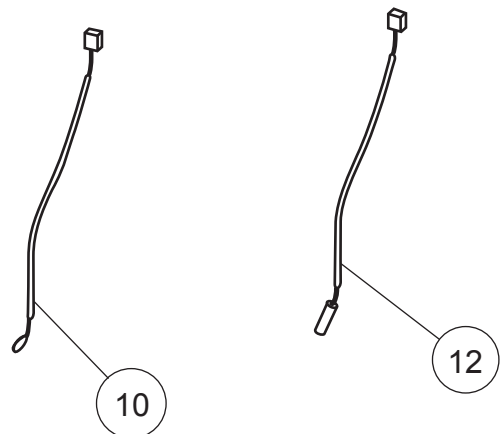

INDOOR UNIT

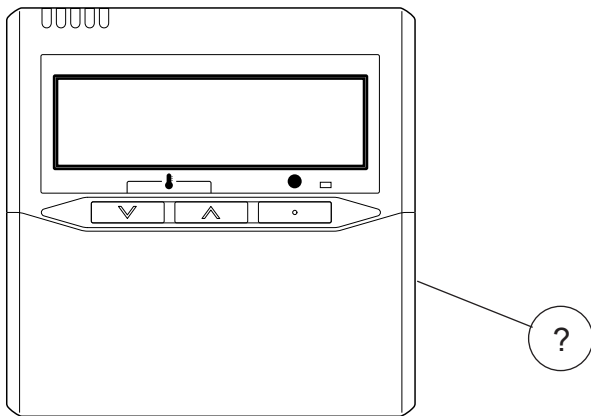
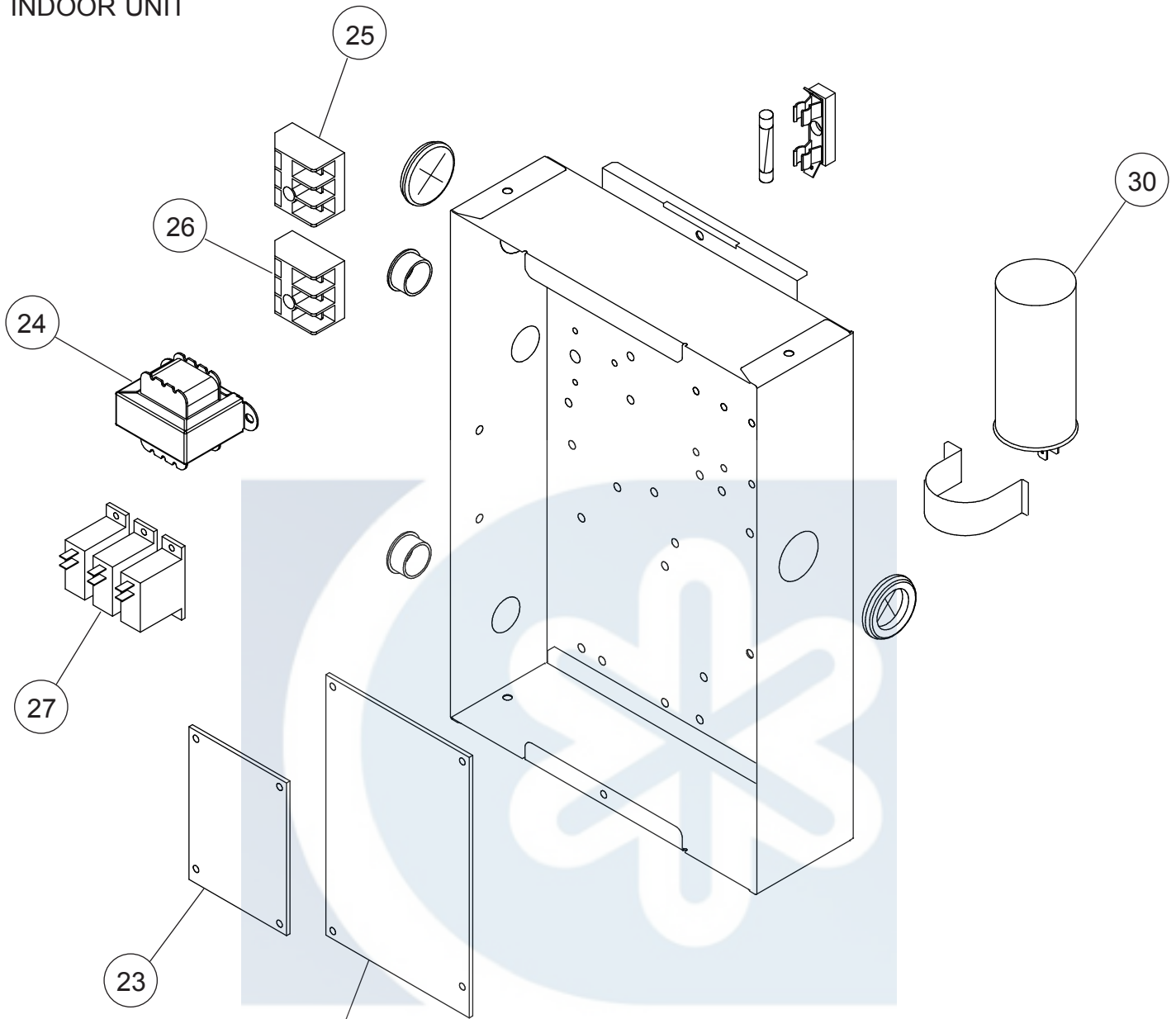

Ref.	Description	Parts number
22	Power Supply PCB	9705668119
23	Main PCB (45)	9705246287
23	Main PCB (54)	9705246294
24	Transformer (Power)	9704129017
25	Terminal 3P	9703345012
26	Terminal 3P	9306489045
27	Relay	9900294014
30	Capacitor, Plastic	9900269111
?	Remote Control	9318593013

PARTS

OUTDOOR UNIT

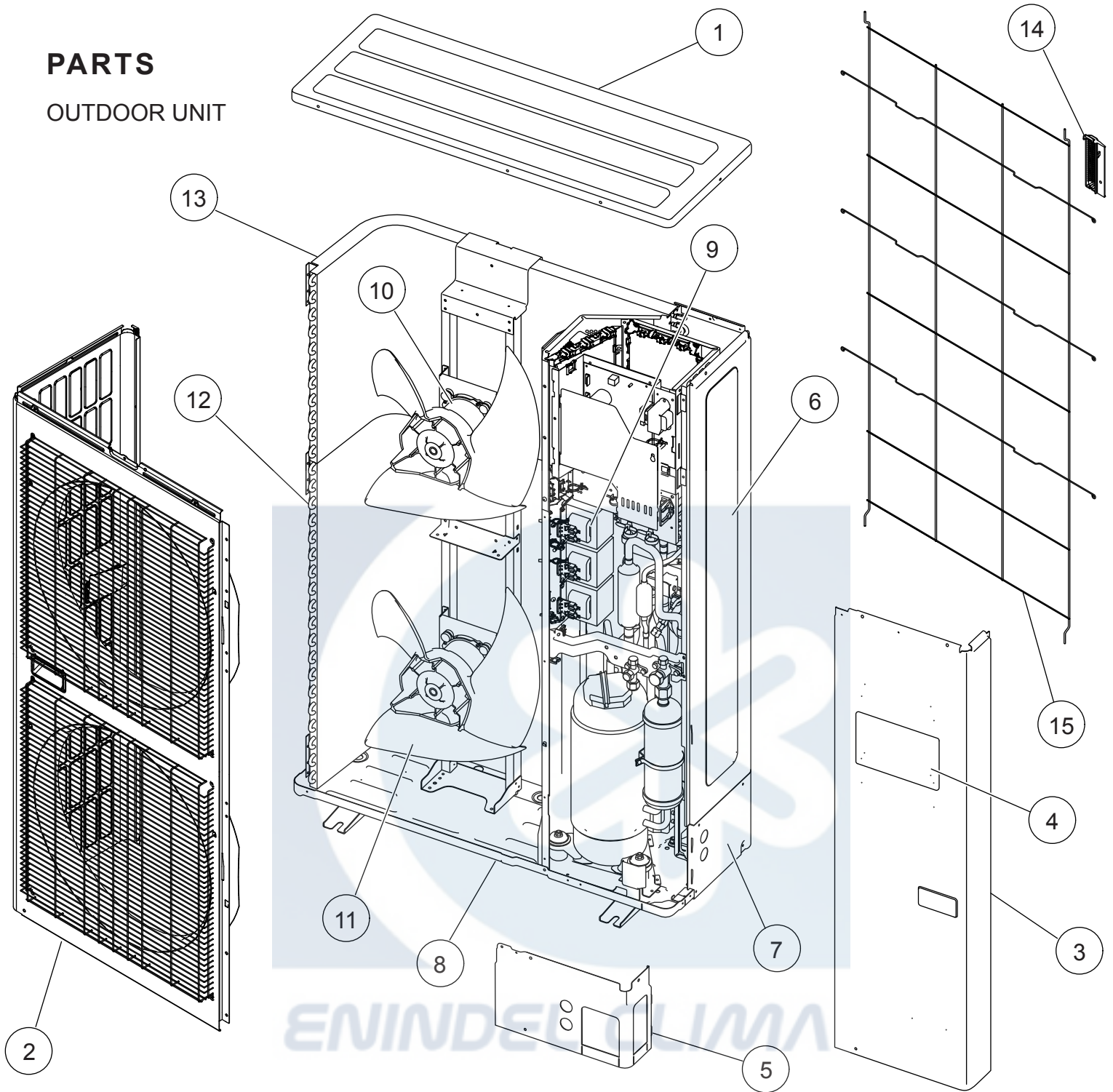

Ref.	Description	Parts number
1	Top Panel Sub Assy	9374417032
2	Front Panel Sub Assy	9374414130
3	Service Panel Sub Assy	9374415076
4	Emblem Rear	9372171059
5	Pipe Cover Front	9378861015
6	Right Panel	9378863019
7	Pipe Cover Rear	9378862012
8	Base Assy	9374166220

Ref.	Description	Parts number
9	Reactor Assy	9900641016
10	Motor, DC Brushless	9602843046
11	Propeller Fan Assy	9366378020
12	Condenser A Sub Assy	9374420261
13	Condenser B Sub Assy	9374422081
14	Thermo Holder	9375211011
15	Protective Net	9375381042

OUTDOOR UNIT

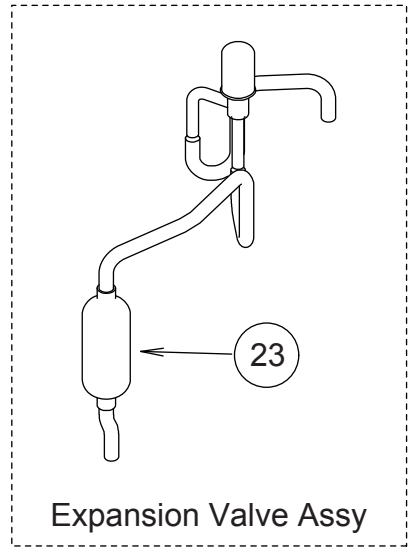
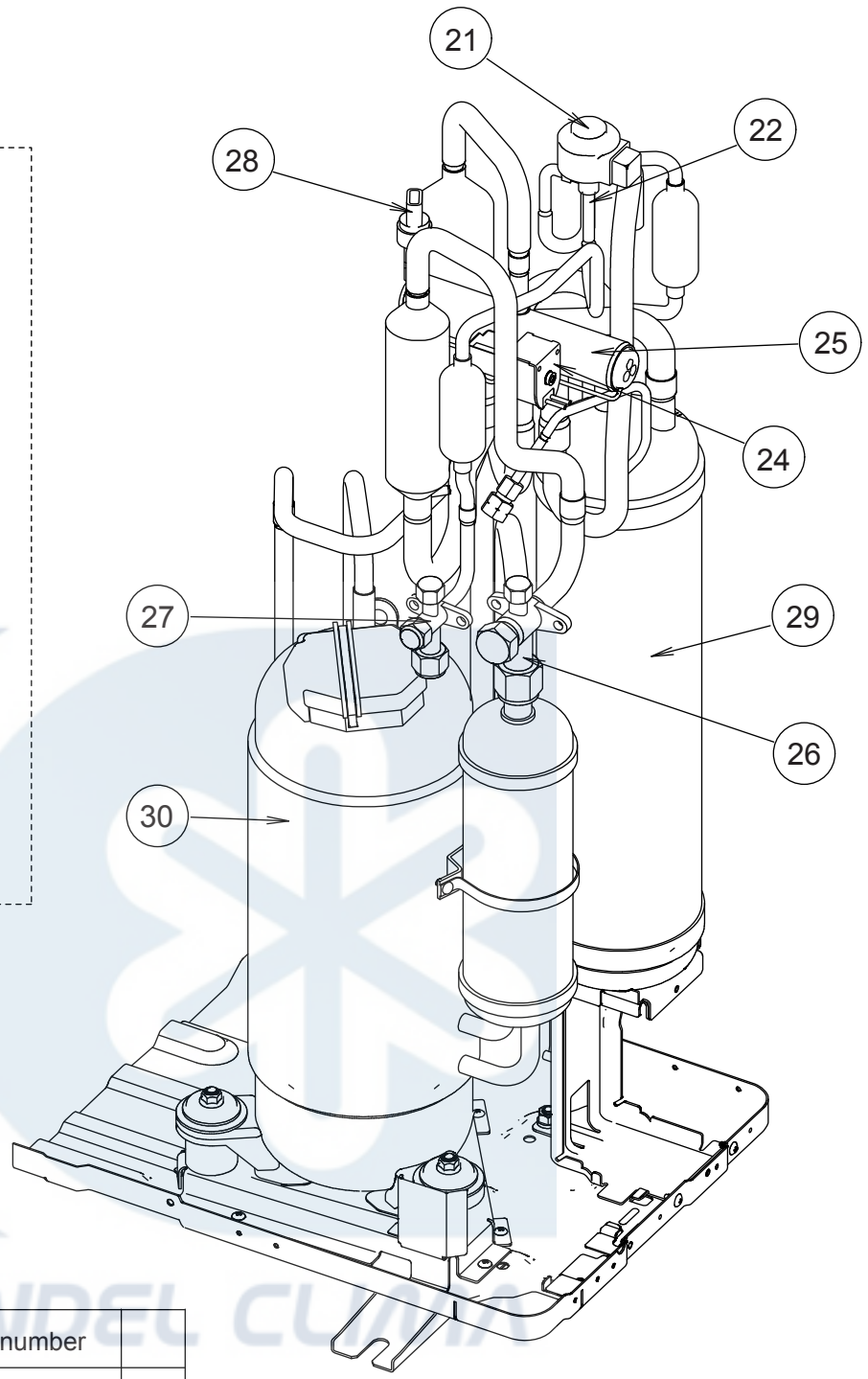
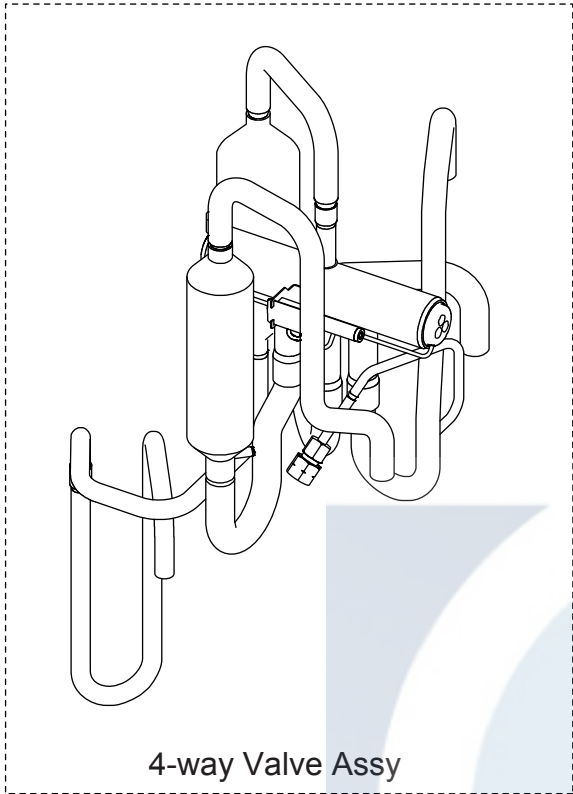

Ref.	Description	Parts number
21	Expansion Valve Coil	9900190057
22	Expansion Valve Assy	9370947182
23	Strainer Assy	9372524039
24	Solenoid	9970113024
25	4-way Valve Assy	9374425273
26	3-way Valve Assy	9379079006
27	3-way Valve Assy	9379077002
28	Sensor	9900505011
29	Accumulator Assy	9375250096
30	Compressor Sub Assy	9374423286



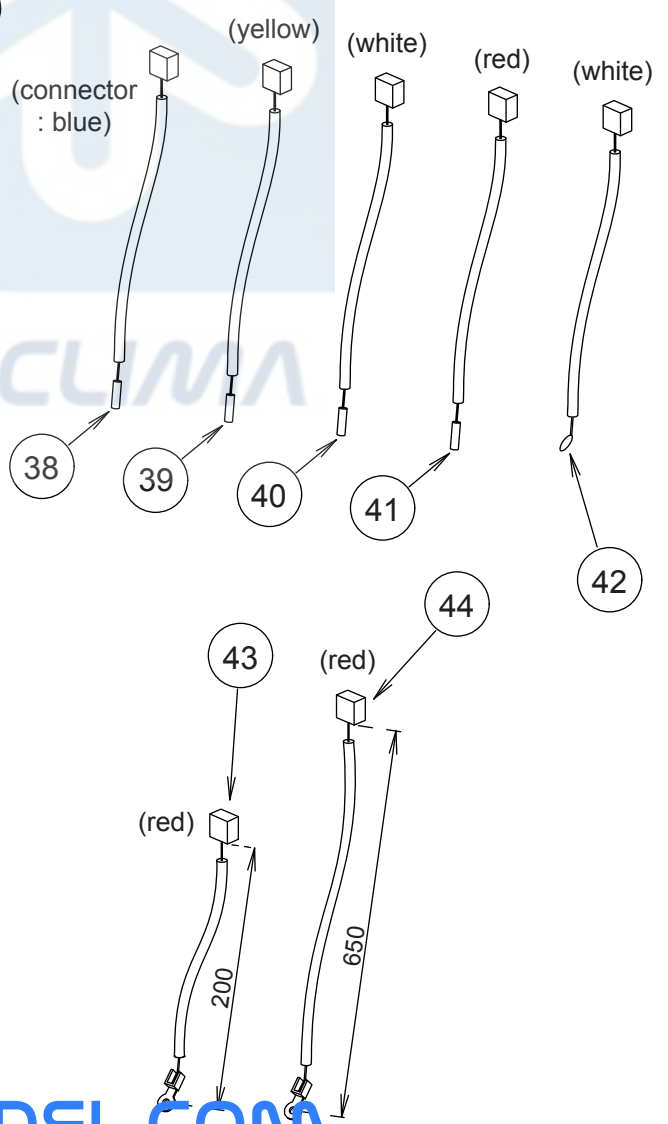
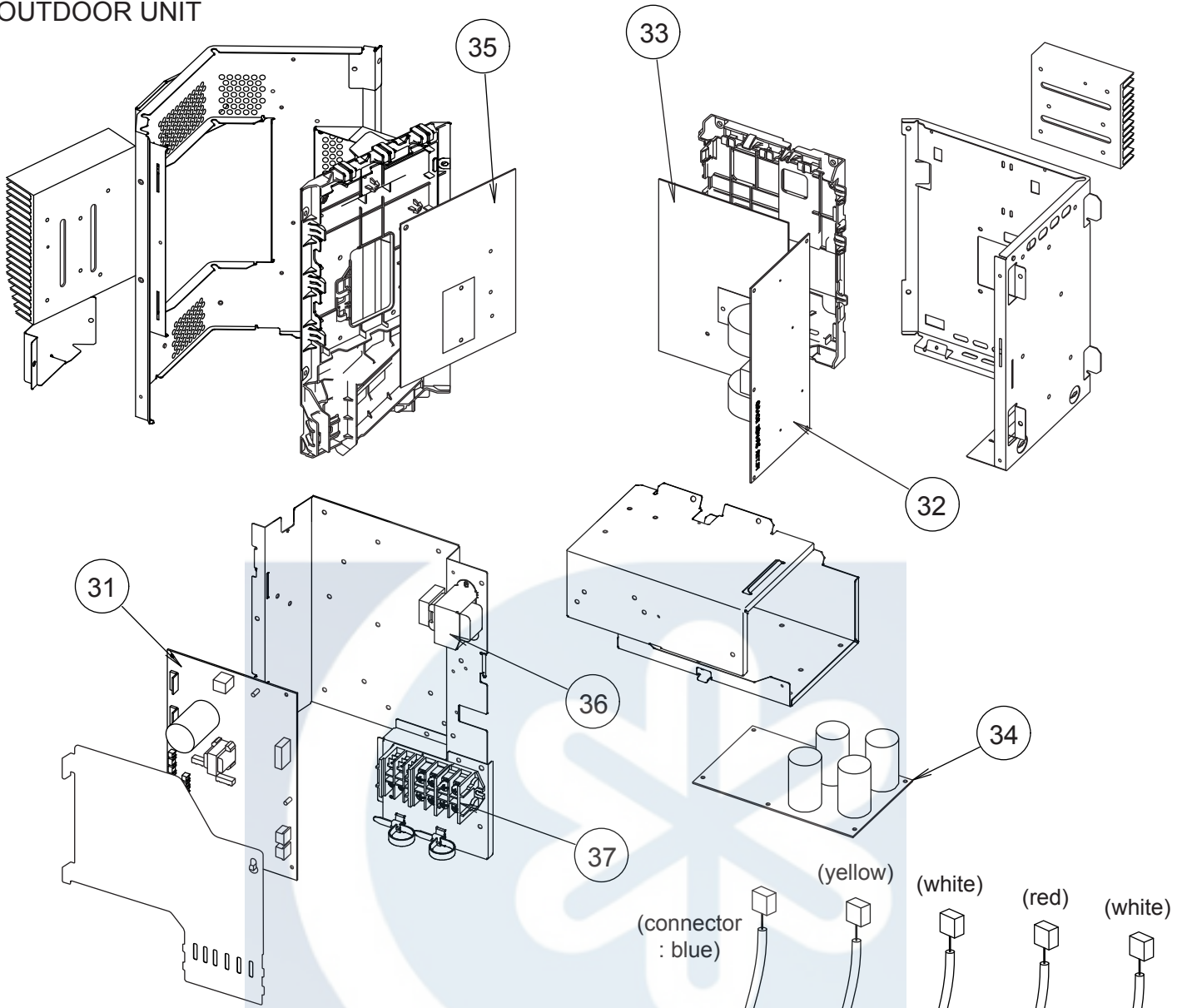



OUTDOOR UNIT



Ref.	Description	Parts number
31	Main PCB (45)	9707627077
31	Main PCB (54)	9707627084
32	Filter PCB	9707609011
33	Active Filter PCB	9709008010
34	Capacitor PCB	9707608014
35	Transistor PCB	9709010020
36	Reactor Assy	9900481018
37	Terminal	9900428082
38	Compressor Thermistor	9900516000
39	Discharge Thermistor	9900515003
40	Thermistor (Heat Exchanger Mid)	9900513009
41	Thermistor (Heat Exchanger Out)	9900514006
42	Outdoor Thermistor	9900517007
43	Heatsink Thermistor (Inverter)	9900518011
44	Heatsink Thermistor (PFC)	9900518028

ACCESSORIES

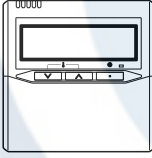
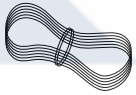
INDOOR UNIT

Name and Shape	Q'ty	Application	Part number
Special nut A (large flange) 	4	For suspending the indoor unit from ceiling	313005446653
Special nut B (small flange) 	4		313005446759
Coupler heat insulation (large) 	1	For indoor side pipe joint (large pipe)	9378173569
Coupler heat insulation (small) 	1	For indoor side pipe joint (small pipe)	9378173521
Cable tie 	1	Fixing the remote cord	313361275805
Remote control 	1	For air conditioner operation	9372266199
Remote control cord 	1	For connecting the remote control	9372714010
Tapping screw (ø4 × 16) 	2	For installing the remote control	0700181108

OUTDOOR UNIT

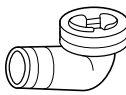
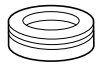
Name and Shape	Q'ty	Application	Part number
Drain pipe 	1	For drain piping work	9303029015
Drain cap 	2		313166024302
One-touch bush	2	For power supply cable and connection cable installation	9378779013

OPTIONAL PARTS

Parts name	Model No.	Application
Simple remote control	UTY-RSN*M	For air conditioner operation
Wired remote control	UTY-RNN*M	For air conditioner operation
Remote sensor unit	UTY-XSZX	Room temperature sensor
External connect kit	UTD-ECS5A	For control input/output port
Long life filter	UTD-LK60KA	

ENINDEL CLIMA



1204G4046

WWW.ENINDEL.COM