



**INVERTER MULTI
AIR CONDITIONER
DUCT type**

**SERVICE
MANUAL**

Refrigerant
R410A

Models

Indoor unit

Outdoor unit

ARH9LUAB

AOH30LMAW4

ENINDEL CLIMA

CONTENTS

SPECIFICATIONS	1
OUTLINE AND DIMENSIONS	3
REFRIGERANT SYSTEM DIAGRAM	5
CIRCUIT DIAGRAM	6
INDOOR PCB CIRCUIT DIAGRAM	8
OUTDOOR PCB CIRCUIT DIAGRAM	9
ERROR CONTENTS	12
DISASSEMBLY ILLUSTRATION	14
PARTS LIST	22

SPECIFICATIONS

INDOOR UNIT

TYPE	Cool and Heat
MODEL NAME	ARH9LUAB

ELECTRICAL DATA

POWER SOURCE	(V)	230
FREQUENCY	(Hz)	50
AIR CIRCULATION-Hi	(m ³ /hr)	450

FAN MOTOR

DISCRIMINATION	MFA-9NTAT	
POWER SOURCE	(V)	230
HI-SPEED	(r.p.m.)	955
MED-SPEED	(r.p.m.)	870
LO-SPEED	(r.p.m.)	800

DIMENSIONS	H x W x D	(mm)	217 x 663 x 595
WEIGHT	GROSS / NET	(kg)	22 / 18

OUTDOOR UNIT

TYPE	Cooling & Heating	
MODEL NAME	AOH30LMAW4	
COOLING CAPACITY	(kW)	8.0
HEATING CAPACITY	(kW)	9.6

ELECTRICAL SPECIFICATIONS

POWER SUPPLY	(V)	(220) - 230 - (240)	
FREQUENCY	(Hz)	50	
RUNNING CURRENT	(A)	COOLING	9.7
		HEATING	10.5
INPUT	(kW)	COOLING	2.22
		HEATING	2.40
EER	(kW/kW)	COOLING	3.60
		HEATING	4.00
AIR CIRCULATION - Hi	(m ³ /hr)	3,300	

COMPRESSOR

TYPE	Hermetic type, Inverter, 4 poles, 3-phase, DC motor, Twin Rotary		
DISCRIMINATION	TNB220FPBM9		
REFRIGERANT	R410	(g)	3,300

FAN MOTOR

DISCRIMINATION	MFE-60PO		
HI-SPEED (COOL/HEAT)	(r.p.m.)	820 / 780	

DIMENSIONS	H x W x D	(mm)	830 x 900 x 330
WEIGHT	NET / GROSS	(kg)	68 / 78

REFRIGERANT CHARGE (R410A)

FULL CHARGE AMOUNT	Total Pipe Length	50.0 m	3,300 g
		60.0 m	3,550 g
		70.0 m	3,800 g
ADDITIONAL CHARGE			25 g / m
CHARGELESS			50 m
MAX PIPE LENGTH (each unit)			25 m
MAX PIPE LENGTH (total)			70 m
MAX ELEVATION (between indoor units)			10 m
MAX ELEVATION (between indoor and outdoor units)			10 m
MIN. PIPE LENGTH (each unit)			5 m

OUTLINE AND DIMENSIONS

(unit : mm)

INDOOR UNIT

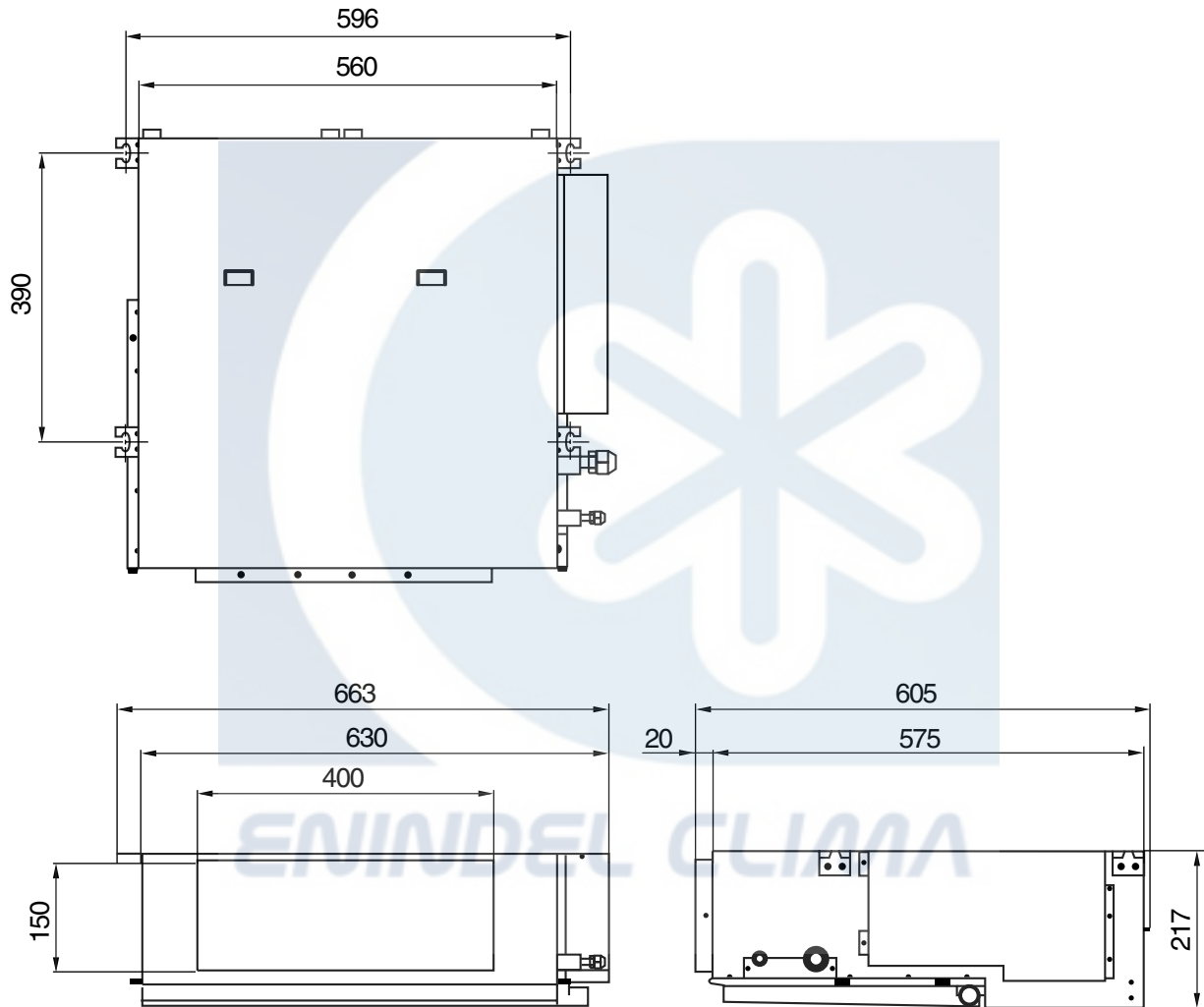

OUTDOOR UNIT (Unit : mm)

Model : AOH30LMAW4

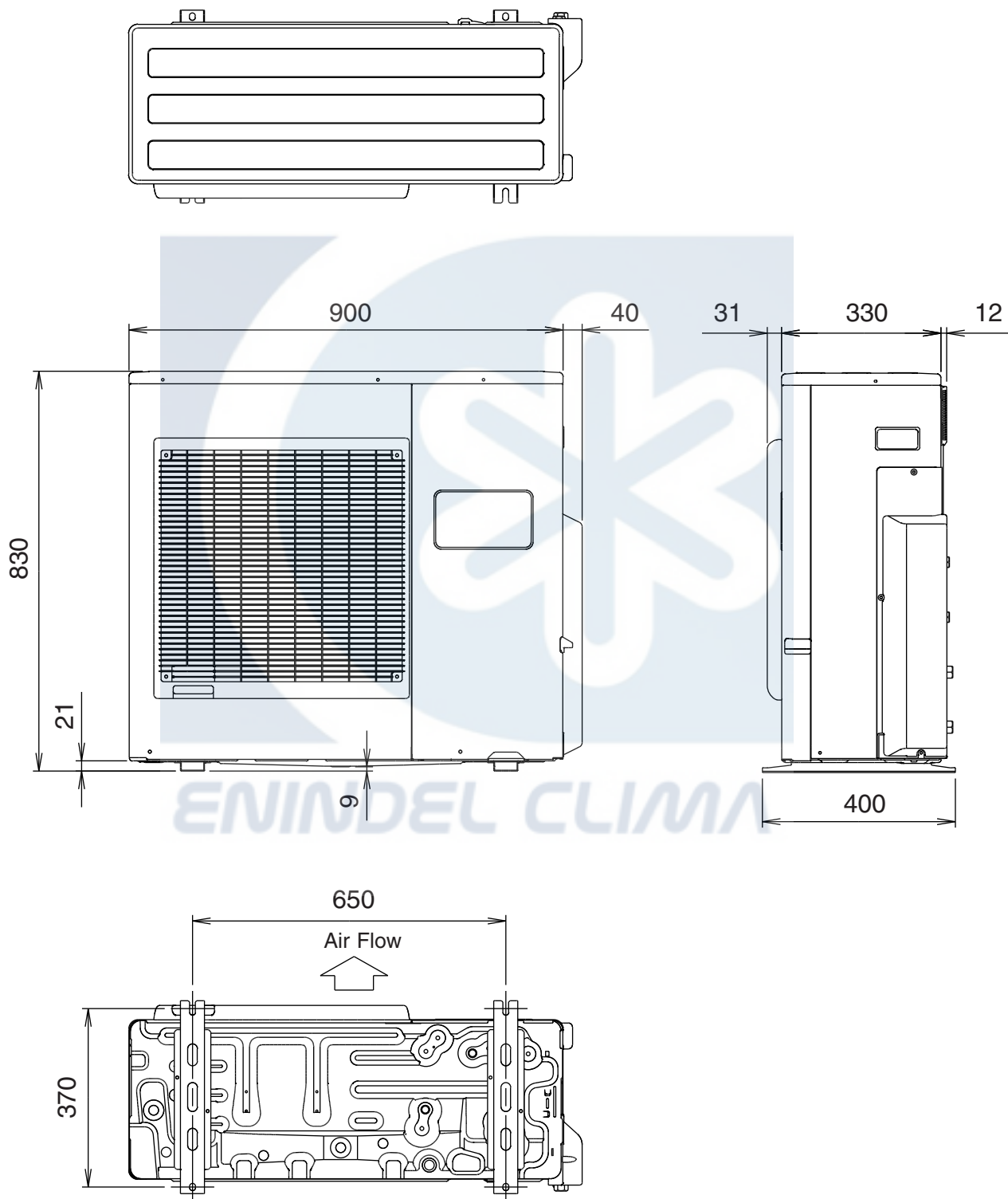

REFRIGERANT SYSTEM DIAGRAM

Outdoor unit

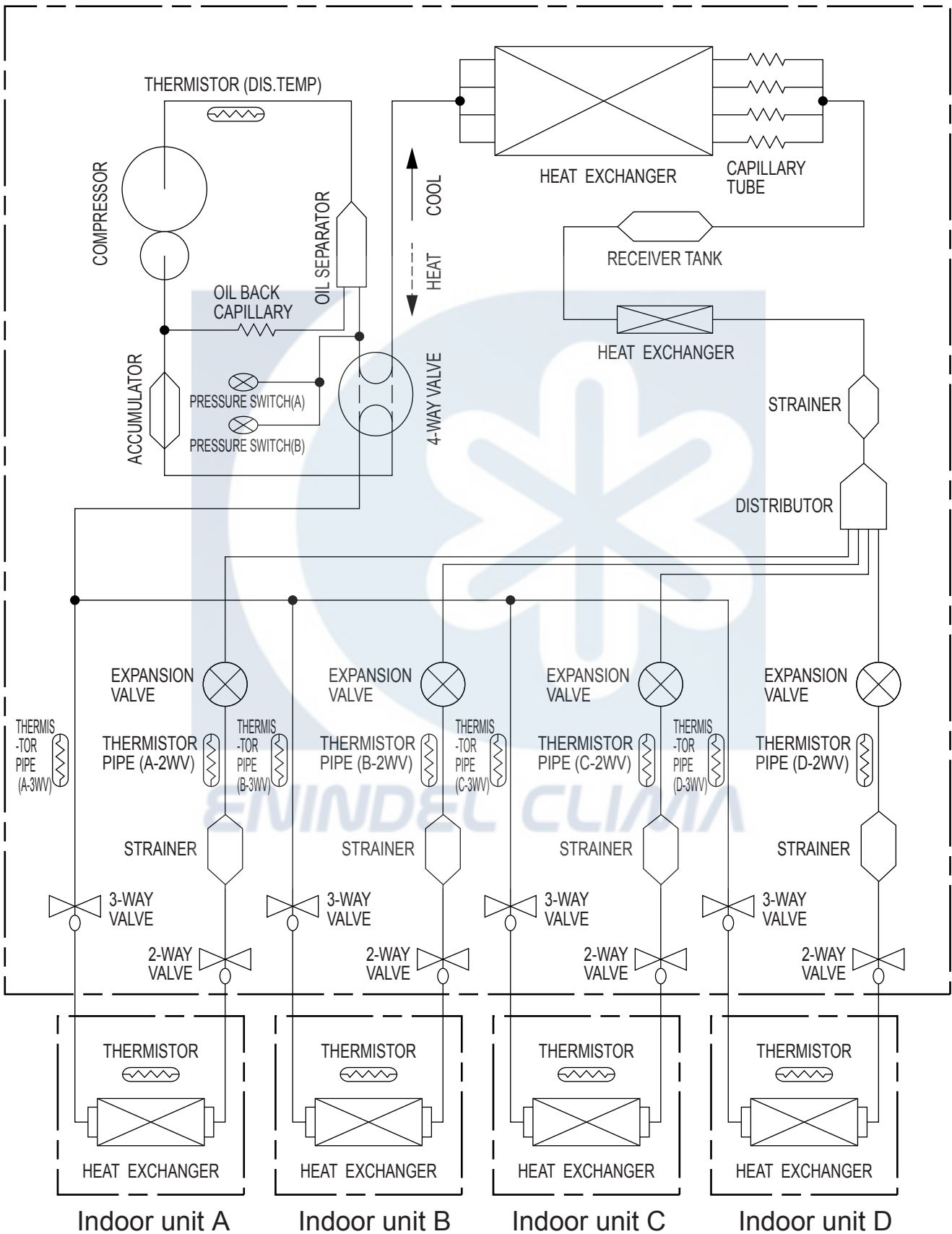

CIRCUIT DIAGRAM

Model : ARH9LUAB

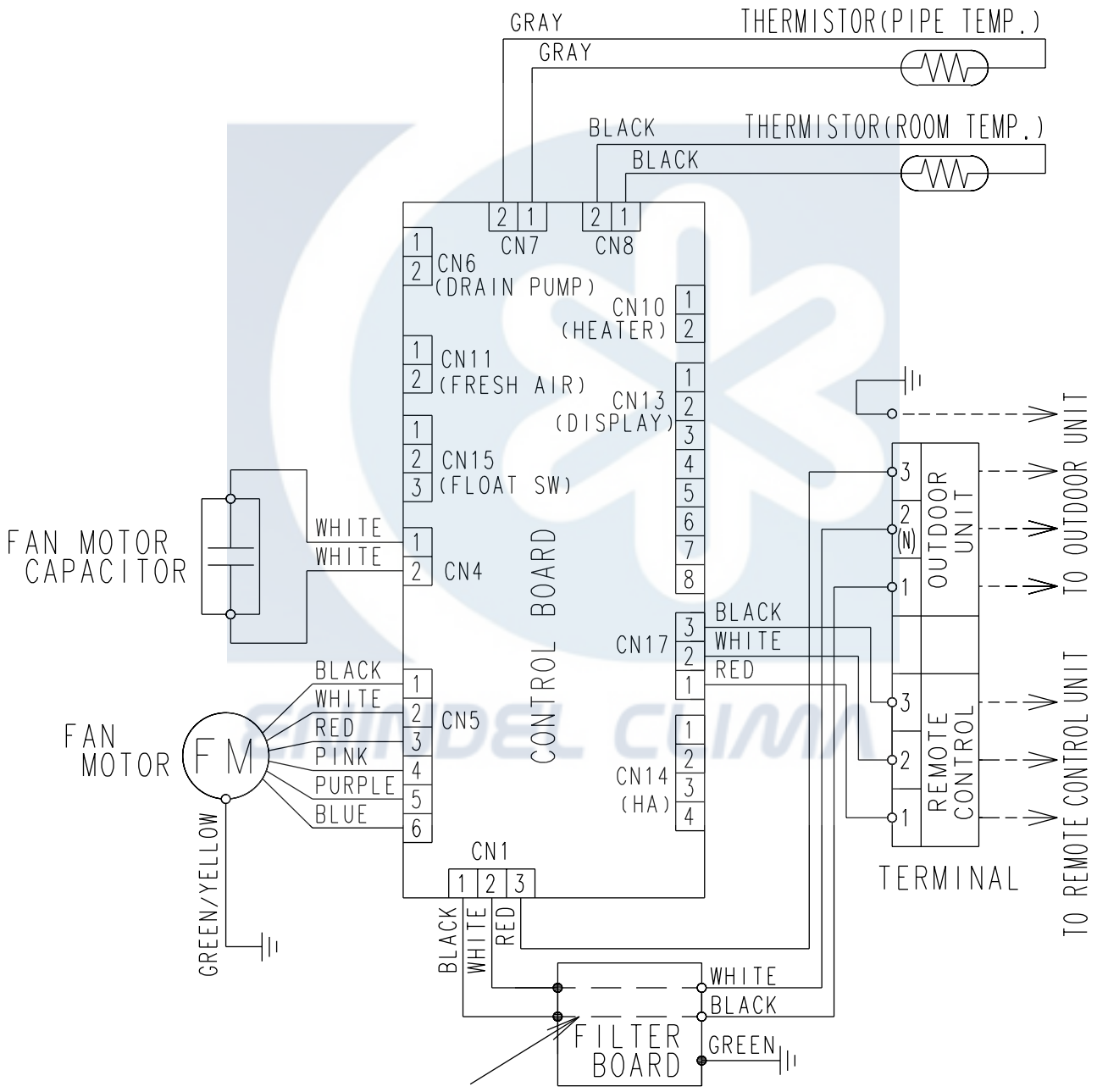

Use T 3.15A-250V
Fuse on F101

Model : AOH30LMAW4

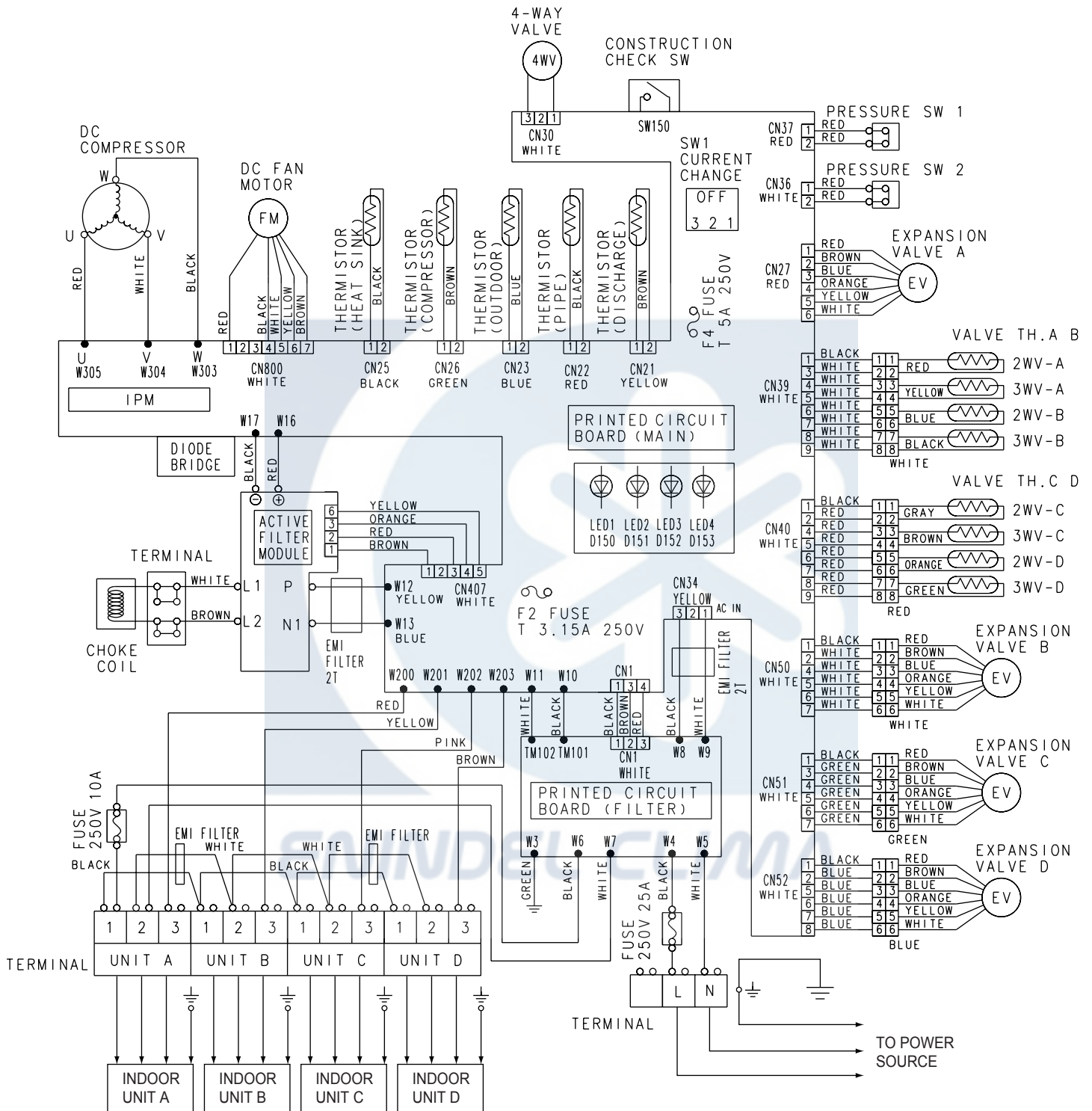

INDOOR PCB CIRCUIT DIAGRAM

Model : ARH9LUAB

CONTROLLER PCB ASSEMBLY (MAIN PCB)

K01AL-0413HSE-C1

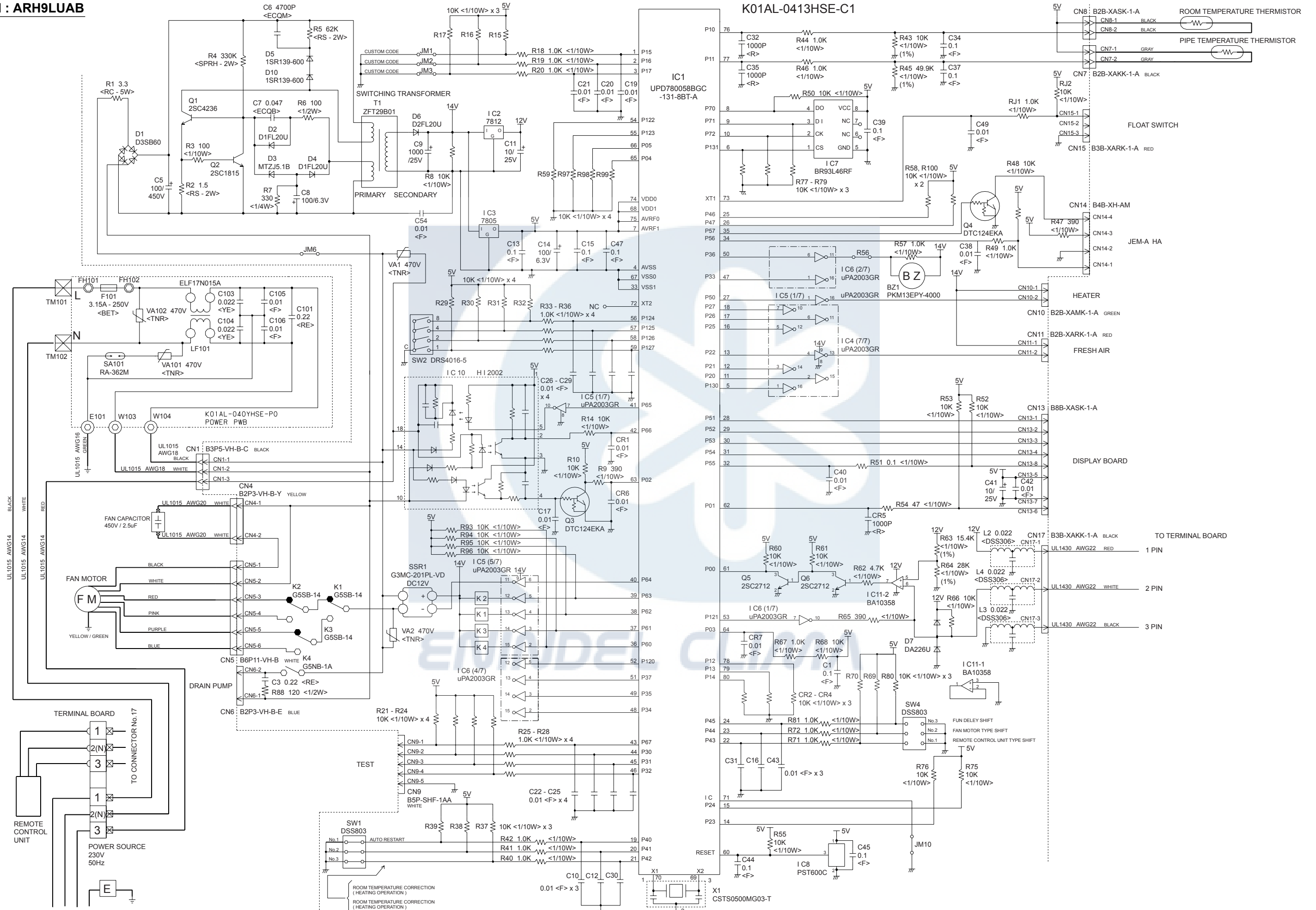

OUTDOOR PCB CIRCUIT DIAGRAM

Model : AOH30LMAW4

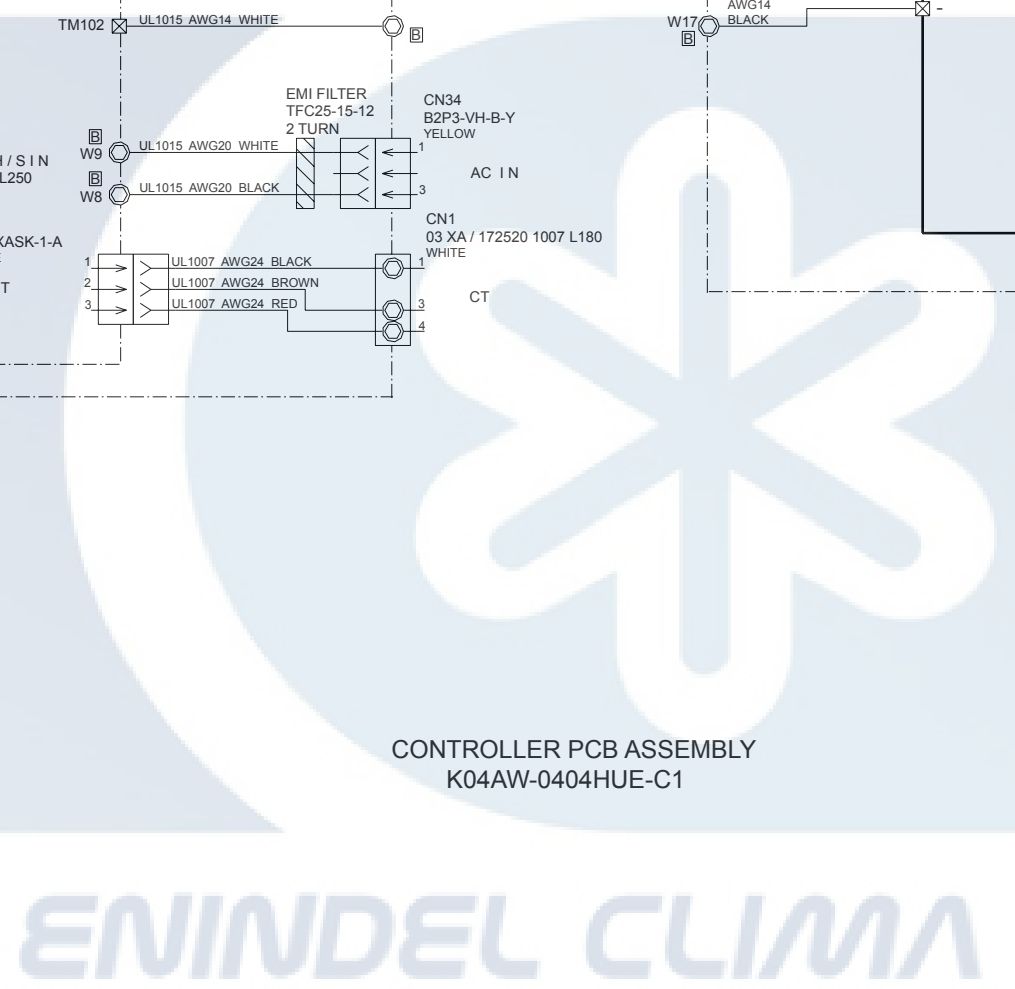
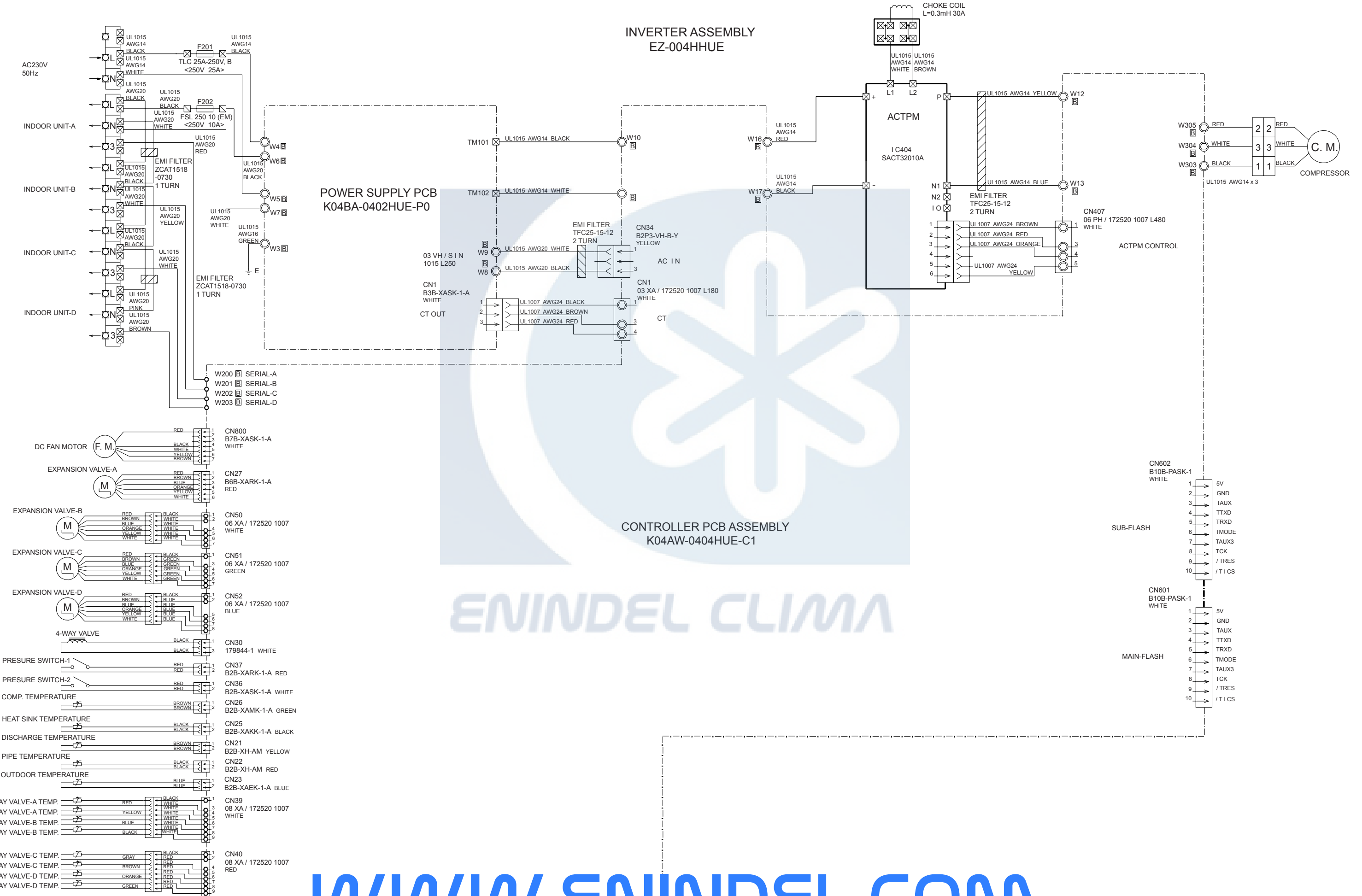

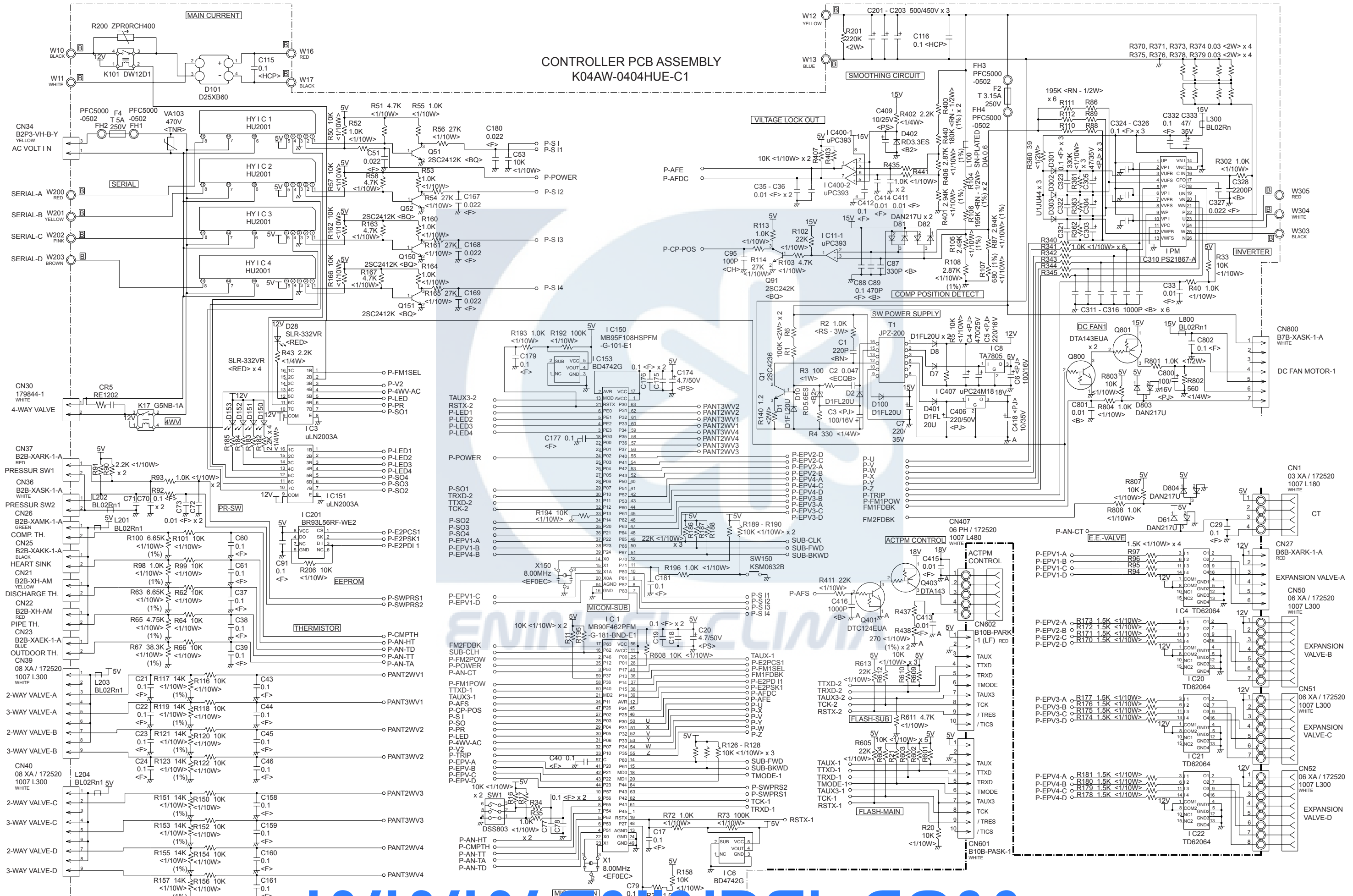

POWER SUPPLY PCB ASSEMBLY
K04BA-0400HUE-P0

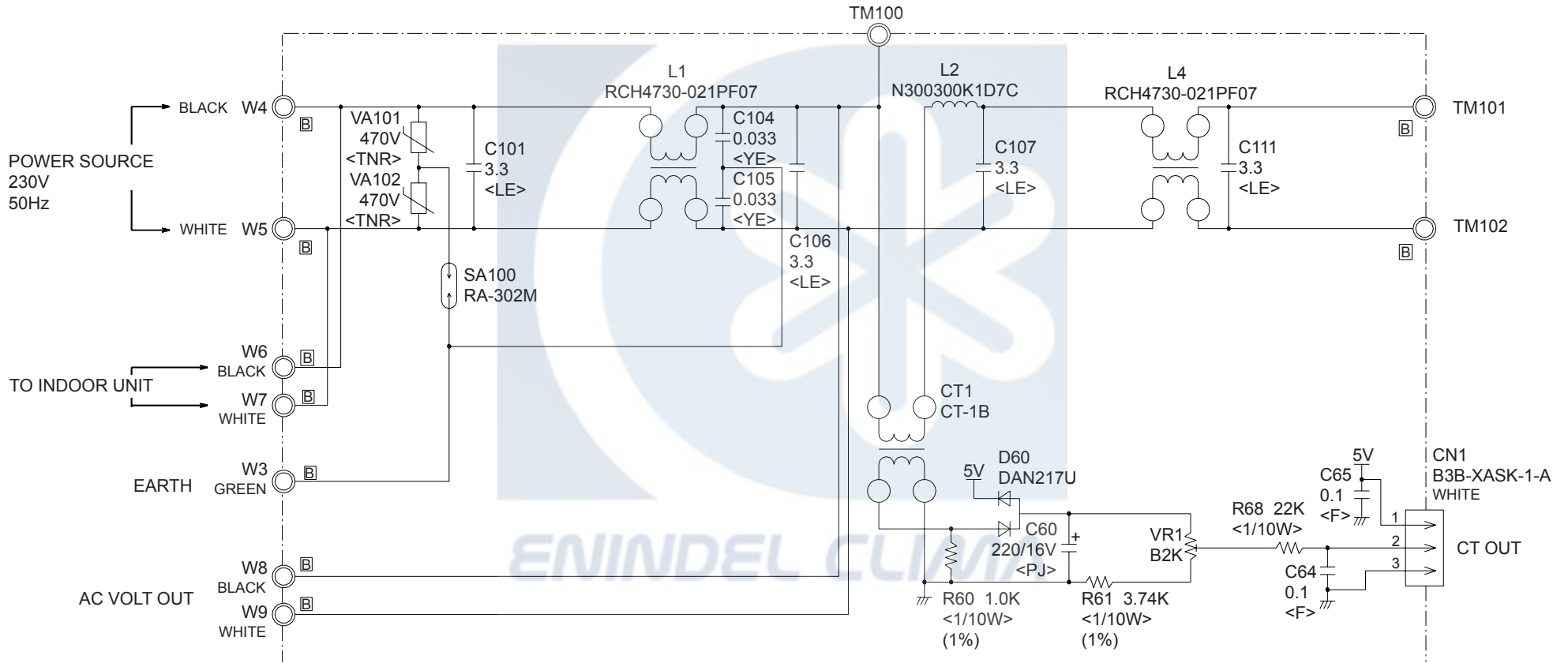

ERROR CONTENTS

- (1) Stop the air conditioner operation.
- (2) Press the master control button and the fan control button simultaneously for 2 seconds or more to start the test run.

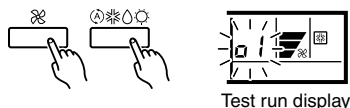

- (3) Press the start/stop button to stop the test run.

[SELF-DIAGNOSIS]

When the error indication "E:EE" is displayed, follow the following items to perform the self-diagnosis. "E:EE" indicates an error has occurred.

1. REMOTE CONTROLLER DISPLAY

- (1) Stop the air conditioner operation.
- (2) Press the set temperature buttons \wedge / \vee simultaneously for 5 seconds or more to start the self-diagnosis.
Refer to the following tables for the description of each error code.

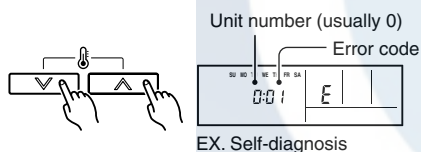

- (3) Press the set temperature buttons \wedge / \vee simultaneously for 5 seconds or more to stop the self-diagnosis.

Error code	Error contents
00	Communication error (indoor unit \leftrightarrow remote controller)
01	Communication error (outdoor unit \rightarrow indoor unit)
02	Room temperature sensor open
03	Room temperature sensor short-circuited
04	Indoor heat exchanger temperature sensor open
05	Indoor heat exchanger temperature sensor short-circuited
06	Outdoor heat exchanger temperature sensor
07	Outdoor heat exchanger temperature thermistor short-circuited
08	Power source connection error
09	Float switch operated
0A	Outdoor temperature sensor
0b	Outdoor temperature thermistor short-circuited
0C	Discharge pipe temperature sensor
0d	Outdoor discharge pipe temperature thermistor short-circuited
0E	Heat sink temperature thermistor error
11	Model abnormal
12	Indoor fan abnormal
13	Outdoor signal abnormal
14	Outdoor EEPROM abnormal
15	Compressor temperature sensor
16	Pressure switch abnormal
17	IPM error
18	CT error
19	Active Filter Module (AFM) error
1A	Compressor cannot operate
1b	Outdoor fan abnormal
1C	Main CPU-sub CPU communication error
1d	2-way valve temperature thermistor error
1E	3-way valve temperature thermistor error
1F	Connected indoor unit error

2.OUTDOOR UNIT LEDS

	LED A	LED B	LED C	LED D
Communication error (indoor unit A to outdoor unit)	● 1 time	—	—	—
Communication error (indoor unit B to outdoor unit)	—	● 1 time	—	—
Communication error (indoor unit C to outdoor unit)	—	—	● 1 time	—
Communication error (indoor unit D to outdoor unit)	—	—	—	● 1 time
Discharge pipe temperature sensor	● 2 times	—	—	—
Outdoor heat exchanger temperature sensor	● 3 times	—	—	—
Outdoor temperature sensor	● 4 times	—	—	—
Outdoor 2way valve(A) temperature sensor	● 5 times	—	—	—
Outdoor 2way valve(B) temperature sensor	—	● 5 times	—	—
Outdoor 2way valve(C) temperature sensor	—	—	● 5 times	—
Outdoor 2way valve(D) temperature sensor	—	—	—	● 5 times
Outdoor 3way valve(A) temperature sensor	● 6 times	—	—	—
Outdoor 3way valve(B) temperature sensor	—	● 6 times	—	—
Outdoor 3way valve(C) temperature sensor	—	—	● 6 times	—
Outdoor 3way valve(D) temperature sensor	—	—	—	● 6 times
Compressor temperature sensor	● 7 times	—	—	—
Heatsink temperature sensor	● 8 times	—	—	—
Pressure switch A abnormal	● 9 times	—	—	—
Pressure switch B abnormal	● 10 times	—	—	—
Indoor unit connection capacity error	● 11 times	—	—	—
IPM error	● 12 times	—	—	—
Compressor later location error	● 13 times	—	—	—
Compressor can not start to operate	● 14 times	—	—	—
Outdoor fan (upper) motor error	● 15 times	—	—	—
Outdoor fan (lower) motor error	● 16 times	—	—	—
Microcomputer error	● 17 times	—	—	—

● : Slow flashing — : Off

DISASSEMBLY ILLUSTRATION

INDOOR UNIT

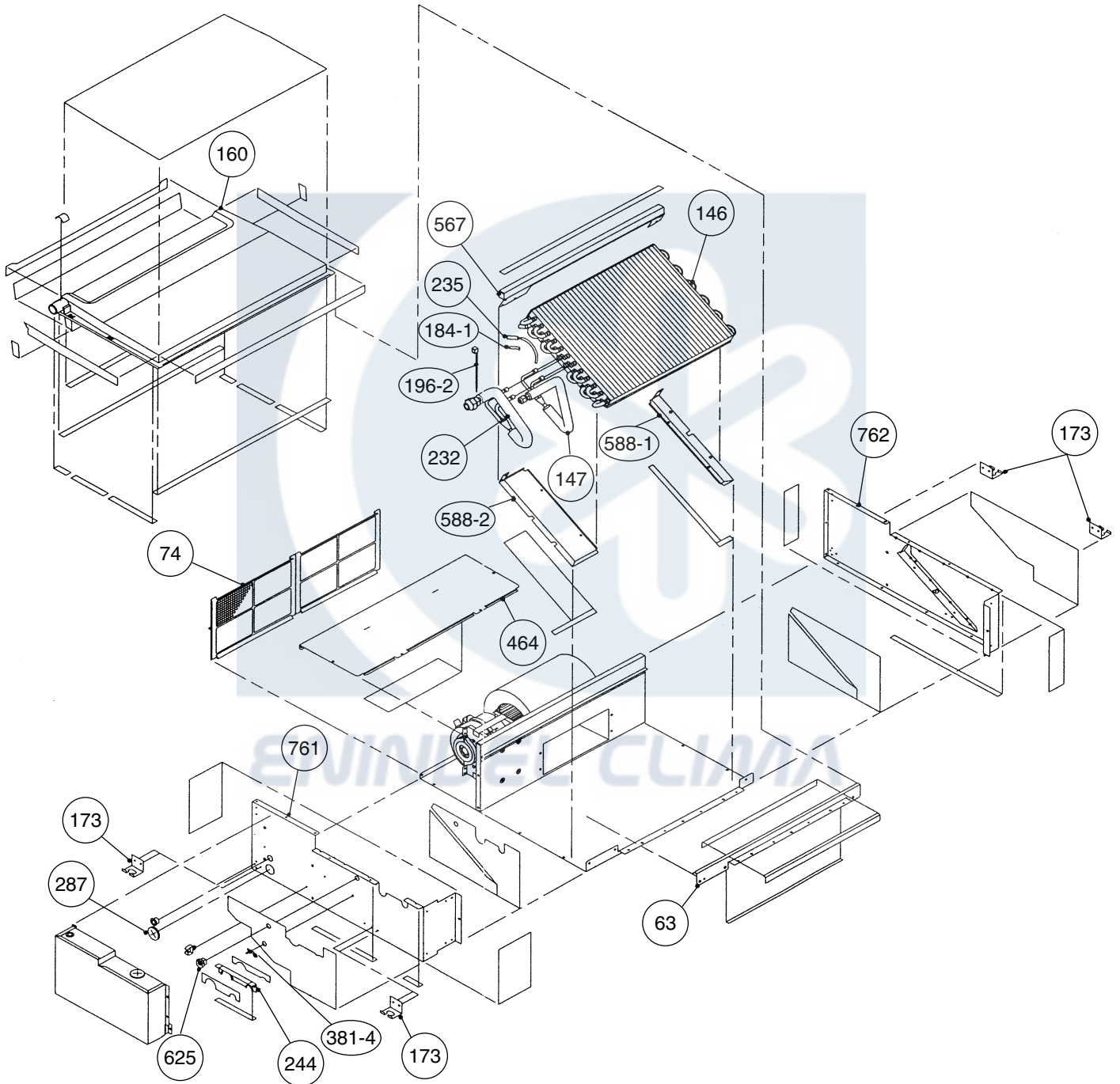

INDOOR UNIT

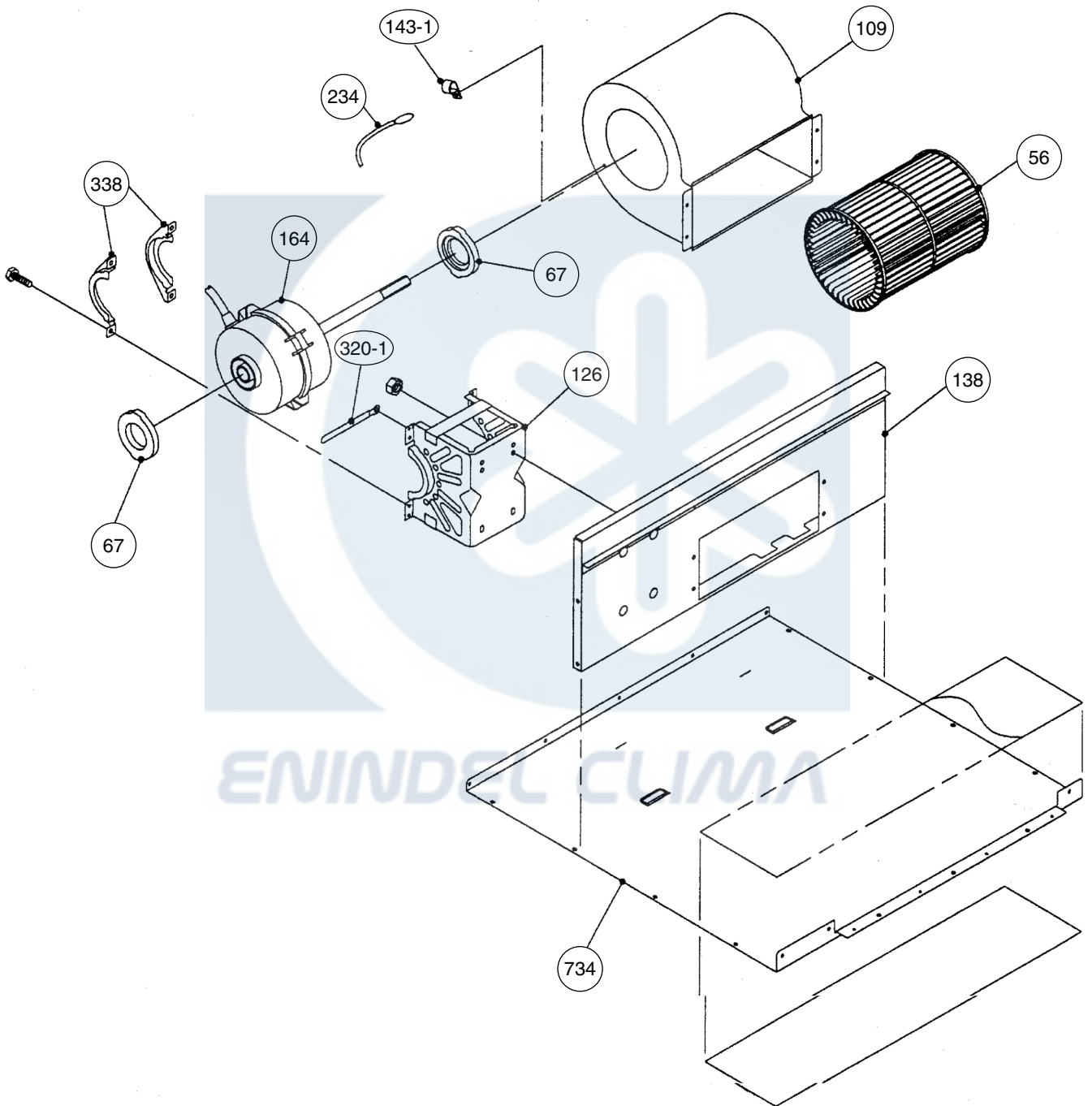

INDOOR UNIT

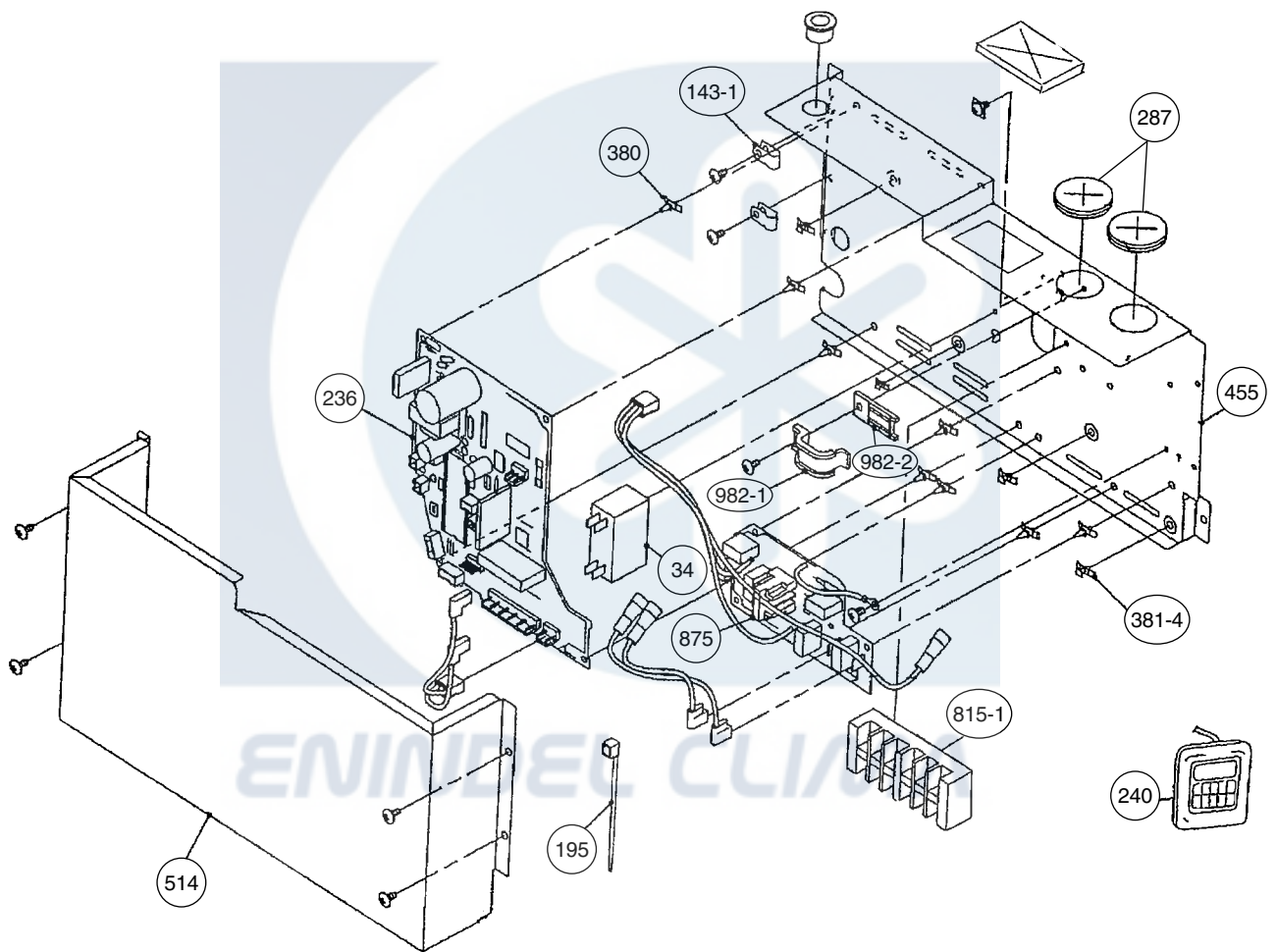

OUTDOOR UNIT

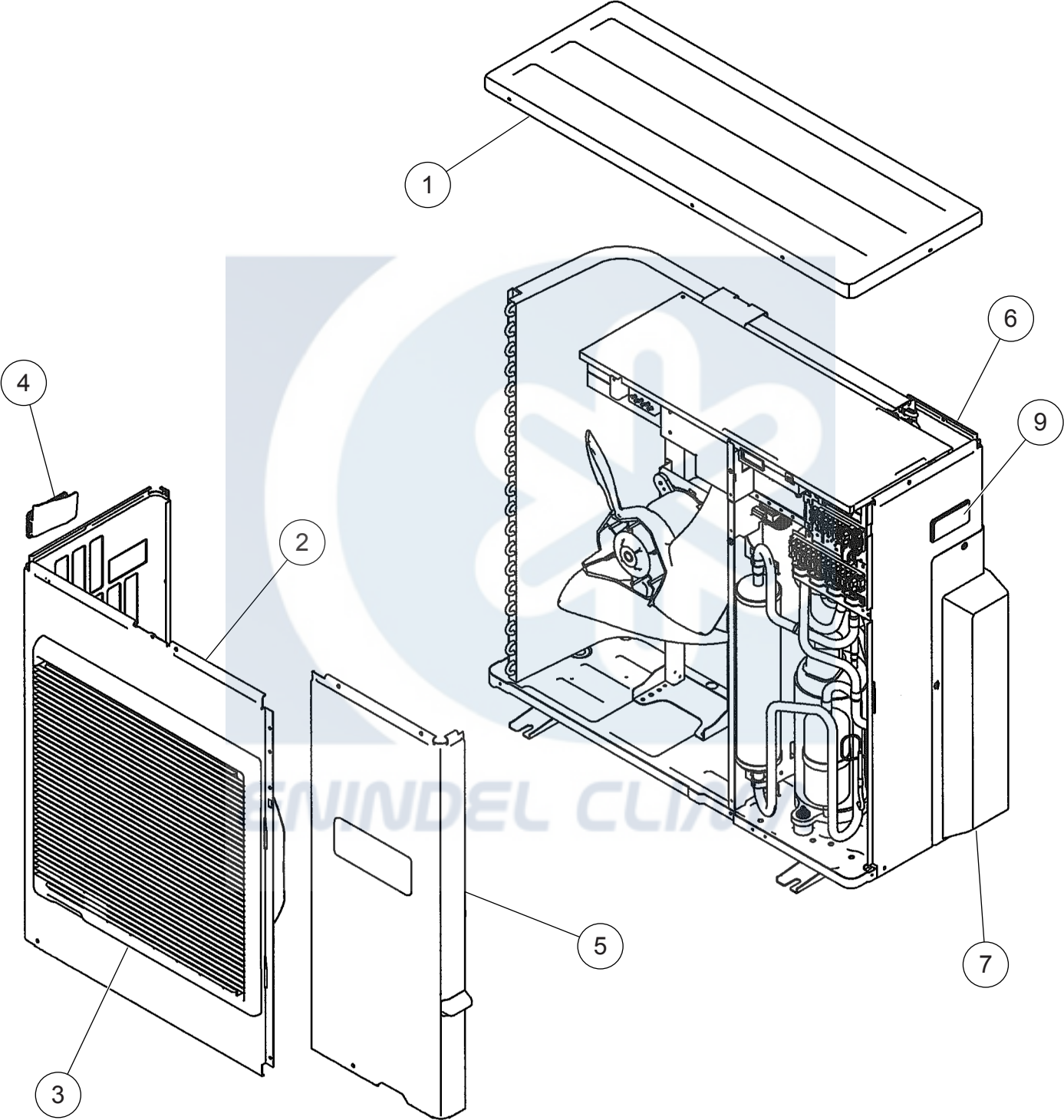

OUTDOOR UNIT

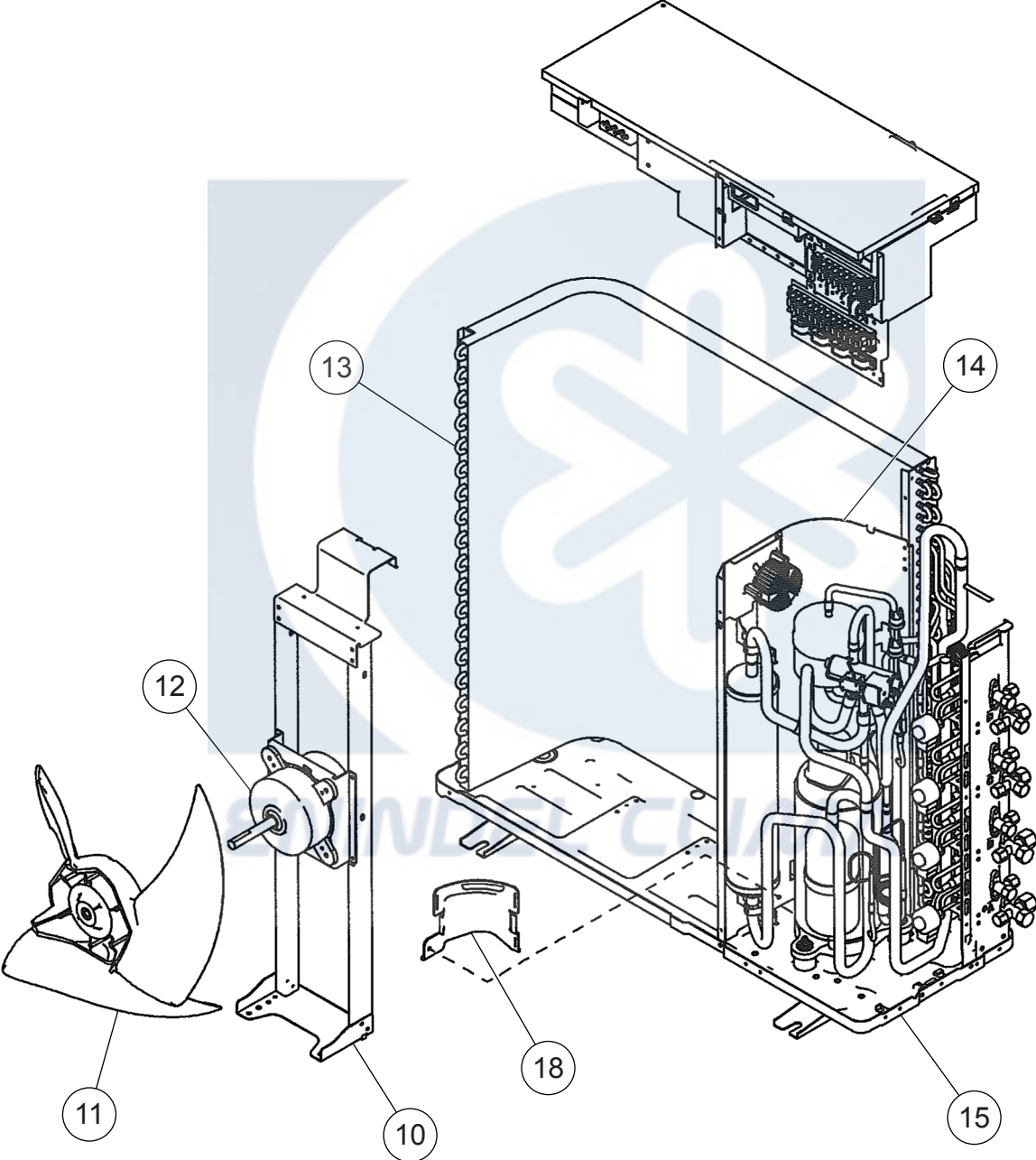

OUTDOOR UNIT

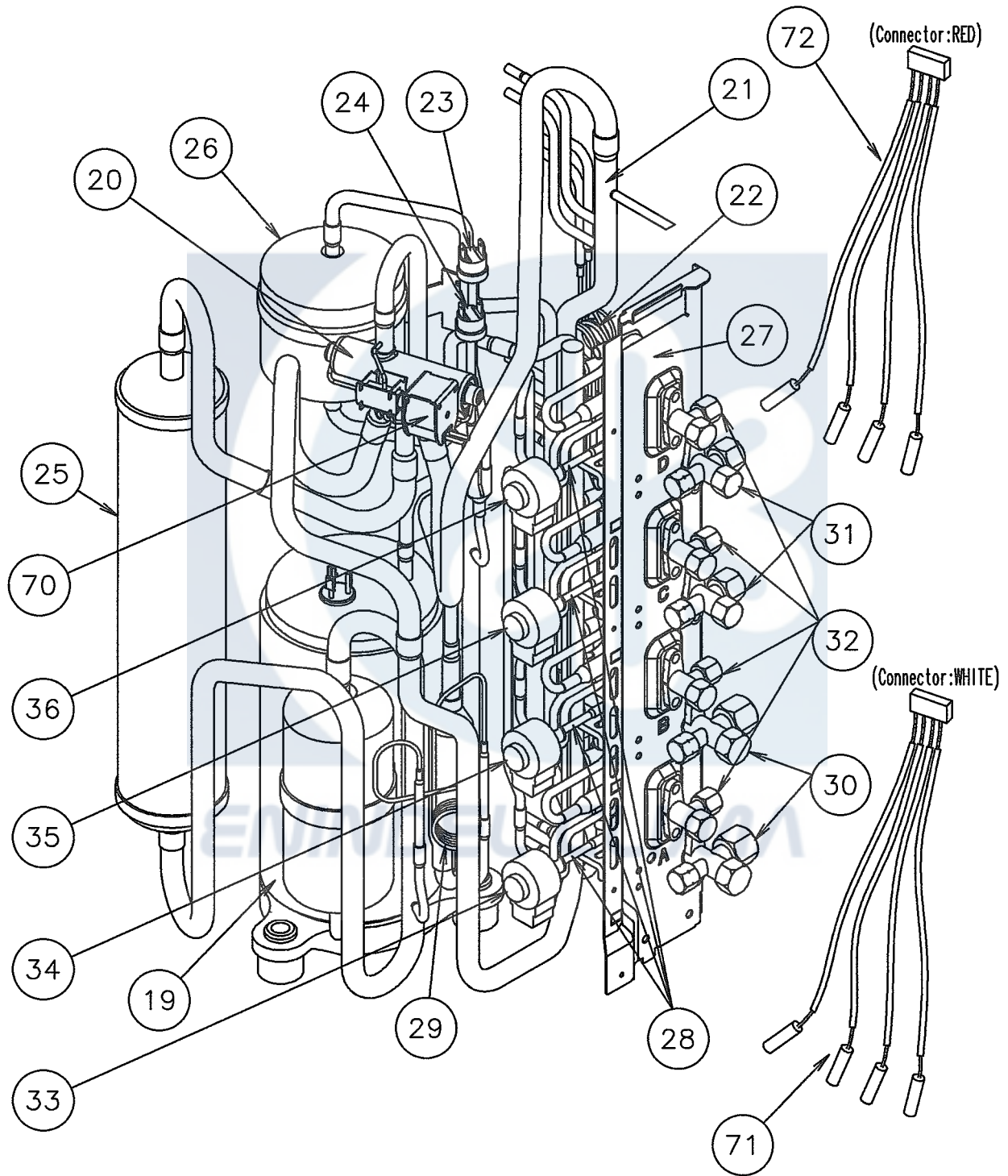

OUTDOOR UNIT
Compressor

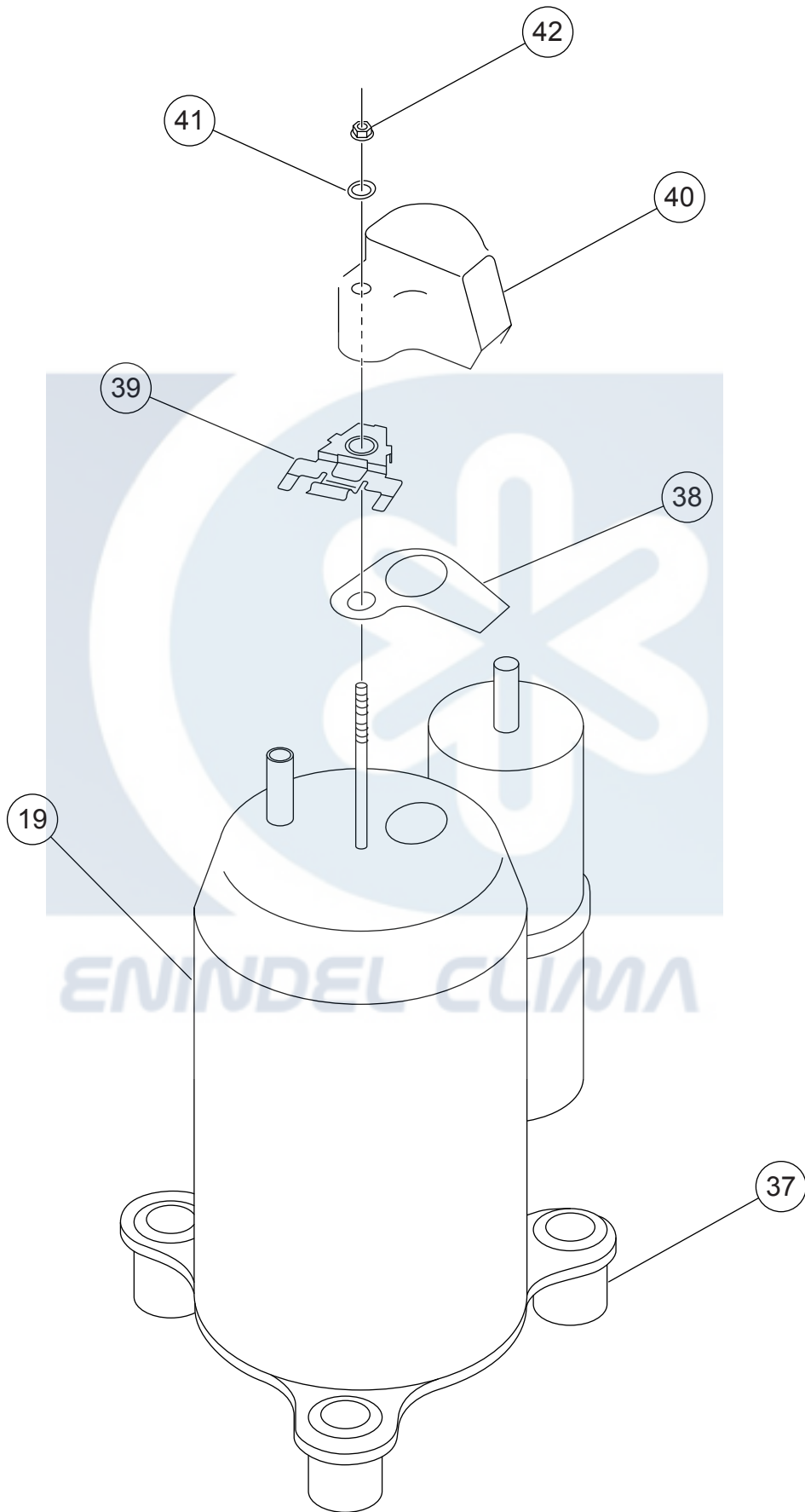

OUTDOOR UNIT
Inverter assy

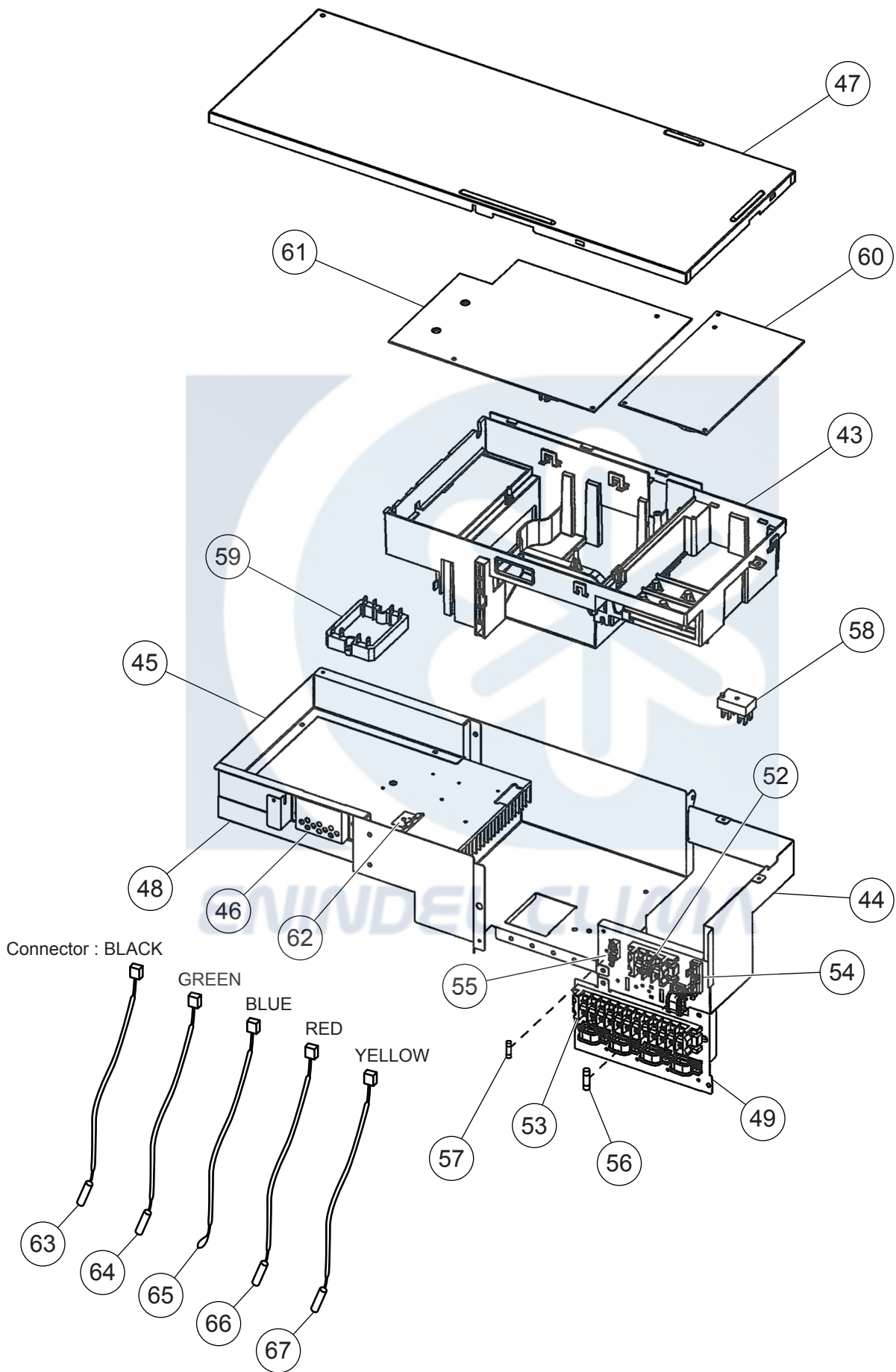

PARTS LIST

INDOOR UNIT











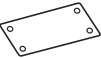

Ref. No.	Description	Part No.	Ord. Q'ty
		ARH9LUAB	
34	Fan Capacitor	9900270186	
56	Sirocco Fan Assy	9358621004	
63	Panel Assy Front	9363722000	
67	Rubber (Vibration-proof)	313659068604	
74	Air Filter	9366833017	
109	Casing Assy	9363322002	
126	Bracket (Motor) Assy	9358591000	
138	Panel Assy (Motor)	9363193008	
143-1	Clamp NK-3N	313361274700	
146	Evaporator Assy	9373255031	
147	Distributor Assy	9373034070	
160	Drain Pan Sub Assy	9364502014	
164	Motor, Induction	9600778203	
173	Hook Metal	9363195002	
184-1	Thermostat Spring-A	313728262708	
195	Binder-C (SKB-100)	313361275805	
196-2	Binder-M (SKB-150)	313035356905	
232	Coupling Pipe Assy	9373038078	
234	Thermistor (Room)	9703299063	
235	Pipe Thermistor	9703297090	
236	Controller PCB Assy	9704557995 (K01AL-0413HSE-C1)	
240	Remote Control Unit	9372266014	
244	Cover (Piping)	9363330007	
287	Cap (Power)	9352173011	
320-1	Wire Clamp Metal	313483219905	
338	Bracket (Motor)	9358594001	
380	Locking Spacer KGLS-6S	313209391403	
381-4	Spacer KGPS-6S	0600118075	
455	Control Box	9366299004	
464	Cabinet Cover Sub Assy	9364503011	
514	Control Box Cover	9363201000	
567	Support Plate (Eva.)	9363323009	
588-1	Bracket Eva. R	9363199000	
588-2	Bracket Eva. L	9363198003	
625	Cord Bush	9359240006	
734	Top Panel Sub Assy	9364507019	
761	Side Panel Right Sub Assy	9364505015	
762	Side Panel Left Sub Assy	9364506012	
815-1	Terminal 7P	9703403019	
875	Filter PCB Assy	9704561251	
982-1	Clamp (Cord)	9356857009	
982-2	Clamp (Cord)-B	9356858006	

OUTDOOR UNIT

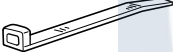





Ref. No.	Description	Part No.	Ord. Q'ty	Ref. No.	Description	Part No.	Ord. Q'ty
		AOH30LMAW4				AOH30LMAW4	
1	Top Panel Sub Assy	9374417025		38	Terminal Packing	9377948014	
2	Front Panel	9374094066		39	Holder	9377952011	
3	Fan Guard	9374330010		40	Terminal Cover (Comp)	9377947017	
4	Grip Side	9374173013		41	Washer (Rubber)	9377949011	
5	Service Panel Assy	9374415038		42	Frange Nut	9377950017	
6	Right Panel M	9374599028		43	Inverter Box A	9374603015	
7	Valve Cover Sub Assy	9374827015		44	Inverter Box B Assy	9374625017	
9	Grip	9374172016		45	Inverter Box C	9374605019	
10	Motor Bracket Sub Assy	9374418053		46	Inverter Box Duct	9374609017	
11	Propeller Fan Assy	9366378020		47	Inverter Box Cover	9374608010	
12	Motor. DC Brushless	9601882015		48	Heat Sink A	9374607013	
13	Condenser A Assy	9374433056		49	Inverter Box D	9374606016	
14	Separate Wall Assy S	9374629022		52	Terminal (3P)	9900203016	
15	Base Assy	9374166084		53	Terminal (12P)	9358660164	
18	Cap Foot	9374345014		54	Fuse Holder (Big)	0501454012	
19	Compressor Assy	9377946010		55	Fuse Holder (Small)	0501456016	
20	4-Way Valve Assy	9374425044		56	Fuse (Big)	0600086039	
21	Inlet Pipe (Cond) A Assy	9373461067		57	Fuse (Small)	0600376116	
22	Outlet Pipe (Cond) A Assy	9374266067		58	Terminal	9701971015	
23	Pressure Switch A Assy	9367726028		59	ACTPM	9703457012	
24	Pressure Switch B Assy	9367727025		60	Power Supply PCB Assy	9705647039	
25	Accumulator Sub Assy	9374426072		61	Controller PCB Assy	9705642058	
26	Receiver Tank Sub Assy	9373426028		62	Holder (Thermo)	9372797013	
27	Valve Plate A Assy	9374628025		63	Heat Sink Thermistor	9900311018	
28	Expansion Valve Assy	9370947106		64	Compressor Thermistor	9900156022	
29	Capillary Assy	9372197370		65	Thermistor (Outdoor Temp)	9703516078	
30	3-Way Valve Assy (1/2")	9372205051		66	Heat Exchanger Thermistor	9704220059	
31	3-Way Valve Assy (3/8")	9372205044		67	Discharge Pipe Thermistor	9704219114	
32	2-Way Valve Assy	9372204054		70	Solenoid	9900165055	
33	Coil (Expansion Valve)(A=Red)	9900057084		71	Pipe Thermistor (White)	9900322014	
34	Coil (Expansion Valve)(B=White)	9900057053		72	Pipe Thermistor (Red)	9900289010	
35	Coil (Expansion Valve)(C=Green)	9900057060		---	Strainer	9372524015	
36	Coil (Expansion Valve)(D=Blue)	9900057077		---	Strainer	9366602019	
37	Rubber Seat (For Comp)	9377951014		---	Emblem Rear	9372171011	

STANDARD ACCESSORIES

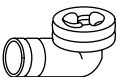
INDOOR UNIT ACCESSORIES

Name and Shape	Q'ty	Application	Parts No.
Installation template 	1	For positioning the indoor unit	9364224008
Hook metal 	4	For suspending the indoor unit from ceiling	9363195002
Tapping screw ($\phi 4 \times 10$) 	8	For installing the hanger	301171164104
Special nut A (large flange) 	4	For suspending the indoor unit from ceiling	313005446653
Special nut B (small flange) 	4		313005446759
Coupler heat insulation (large) 	1	For indoor side pipe joint (large pipe)	9350716029
Coupler heat insulation (small) 	1	For indoor side pipe joint (small pipe)	9352766015
Binder 	(Small) 1	For remote controller and remote controller cord binding	313361275805
	(Large) 4	For fixing the coupler heat insulation	312300787605
Remote control unit 	1	Heat & Cool model	9372266014
		Cool model	9372266021
Remote controller cord 	1	For connecting the remote controller	9372714010
Tapping screw ($\phi 4 \times 16$) 	2	For installing the remote controller	0700181108
Filter 	3		9366833017
Drain hose insulation 	1	Insulates the drain hose and vinyl hose connection	313806217708

OUTDOOR UNIT ACCESSORIES

Name and Shape	Q'ty	Application	Name and Shape	Q'ty	Application
Drain pipe 	1	For outdoor unit drain piping work (May not be supplied, depending on the model.)	Adapter E (1/4"→3/8") 6.35mm → 9.52mm 	1	For connecting a pipe with different diameter to the outdoor unit.
Drain cap 	2		Adapter G (1/2"→5/8") 12.7mm → 15.88mm 	1	
Putty 	1		Adapter D (1/2"→3/8") 12.7mm → 9.52mm 	2	



0504G2819

WWW.ENINDEL.COM