



SPLIT TYPE
AIR CONDITIONER (50Hz)

DUCT type

SERVICE MANUAL

Models	Indoor unit	Outdoor unit
	ARG25FUAA	AOG25FNAKL
	ARG25UUA	AOG25UNAKL

Refrigerant
R410A

preliminary

ENINDEL CLIMA

C O N T E N T S

SPECIFICATIONS	1
OUTLINE AND DIMENSIONS.....	3
CIRCUIT DIAGRAM	5
REFRIGERANT SYSTEM DIAGRAM	7
ERROR CONTENTS	8
INDOOR PRINTED CIRCUIT BOARD CIRCUIT DIAGRAM	9
OUTDOOR PRINTED CIRCUIT BOARD CIRCUIT DIAGRAM.....	11
DISASSEMBLY ILLUSTRATION	12
PARTS LIST	20
ACCESSORIES	23

S P E C I F I C A T I O N S

TYPE		COOLING	COOLING & HEATING
INDOOR UNIT		ARG25FUAA	ARG25JUAA
OUTDOOR UNIT		AOG25FNAKL	AOG25UNAKL
COOLING CAPACITY	(kW)	7.05	7.00
HEATING CAPACITY	(kW)	-----	7.70

ELECTRICAL DATA

POWER SOURCE	(V)	230		
FREQUENCY	(Hz)	50		
RUNNING CURRENT	(A)	COOLING	11.5	11.8
		HEATING	-----	10.5
INPUT WATTS	(kW)	COOLING	2.60	2.65
		HEATING	-----	2.33
E.E.R.	(kW / kW)	COOLING	2.71	2.64
		HEATING	-----	3.30
STARTING CURRENT	(A)	60		
MOISTURE REMOVAL	(ℓ/hr)	2.5		

Note : The above list shows values at the external static pressure of 98Pa (10mm Ag), setting the fan speed high notch.

COMPRESSOR

TYPE	Hermetic type, 2 pole, Single phase, Induction motor, Rotary		
DISCRIMINATION	5JS290DAA		
REFRIGERANT	R410A	(g)	1,550 2,000

FAN SPEED	INDOOR	HIGH	1,160	
		MED	1,060	
		LOW	960	
	OUTDOOR	780		
AIR FLOW	INDOOR	1,050		
	OUTDOOR	3,200		
DIMENSIONS	INDOOR	270 x 1,210 x 700		
	OUTDOOR	650 x 830 x 320		
WEIGHT	INDOOR	43 / 58		
	NET / GROSS (kg)	OUTDOOR	58 / 62	59 / 63
MAX PIPE LENGTH / HEIGHT	(m)	25 / 15		
REMOTE CONTROLLER TYPE		WIRED		

Note : The above list shows values at the external static pressure of 98Pa (10mm Ag), setting the fan speed high notch.

TYPE	COOLING	COOLING & HEATING
INDOOR UNIT	ARG25FUAA	ARG25JUAA
OUTDOOR UNIT	AOG25FNAKL	AOG25UNAKL

NOISE LEVEL

INDOOR UNIT	HI-SPEED (dB)	39
	MED-SPEED (dB)	37
	LO-SPEED (dB)	35
OUTDOOR UNIT (dB)		53
		COOL 53 / HEAT 54

Note : Static pressure : 100Pa
Duct length : Inlet 1m, Outlet 2m

REFRIGERANT CHARGE

FULL CHARGE AMOUNT	PIPE LENGTH	7.5 m (24 ft.)	1,550 g (54.7 oz)	2,000 g (70.6 oz)
		10 m (33 ft.)	1,600 g (56.4 oz)	2,100 g (74.1 oz)
		15 m (49 ft.)	1,700 g (60.0 oz)	2,300 g (81.1 oz)
		20 m (66 ft.)	1,800 g (63.5 oz)	2,500 g (88.2 oz)
		25 m (82 ft.)	1,900 g (67.0 oz)	2,700 g (95.2 oz)
Additional refrigerant			20 g / m (0.7 oz / 3.3 ft.)	40 g / m (1.4 oz / 3.3 ft.)

ENINDEL CLIMA

DIMENSIONS

INDOOR UNIT

Models : ARG25FUAA
ARG25UUAA

Unit : mm

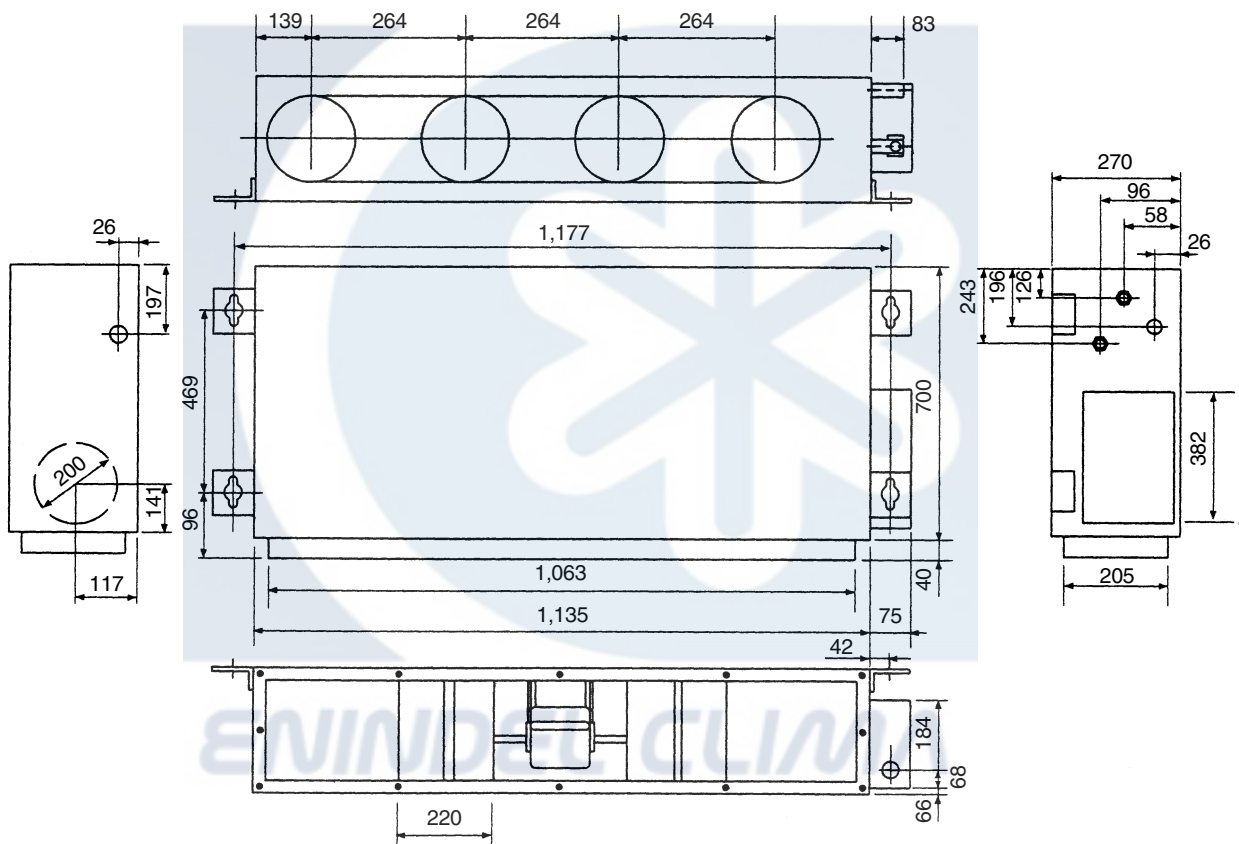

OUTDOOR UNIT

Models : AOG25FNAKL
AOG25UNAKL

Unit : (mm)

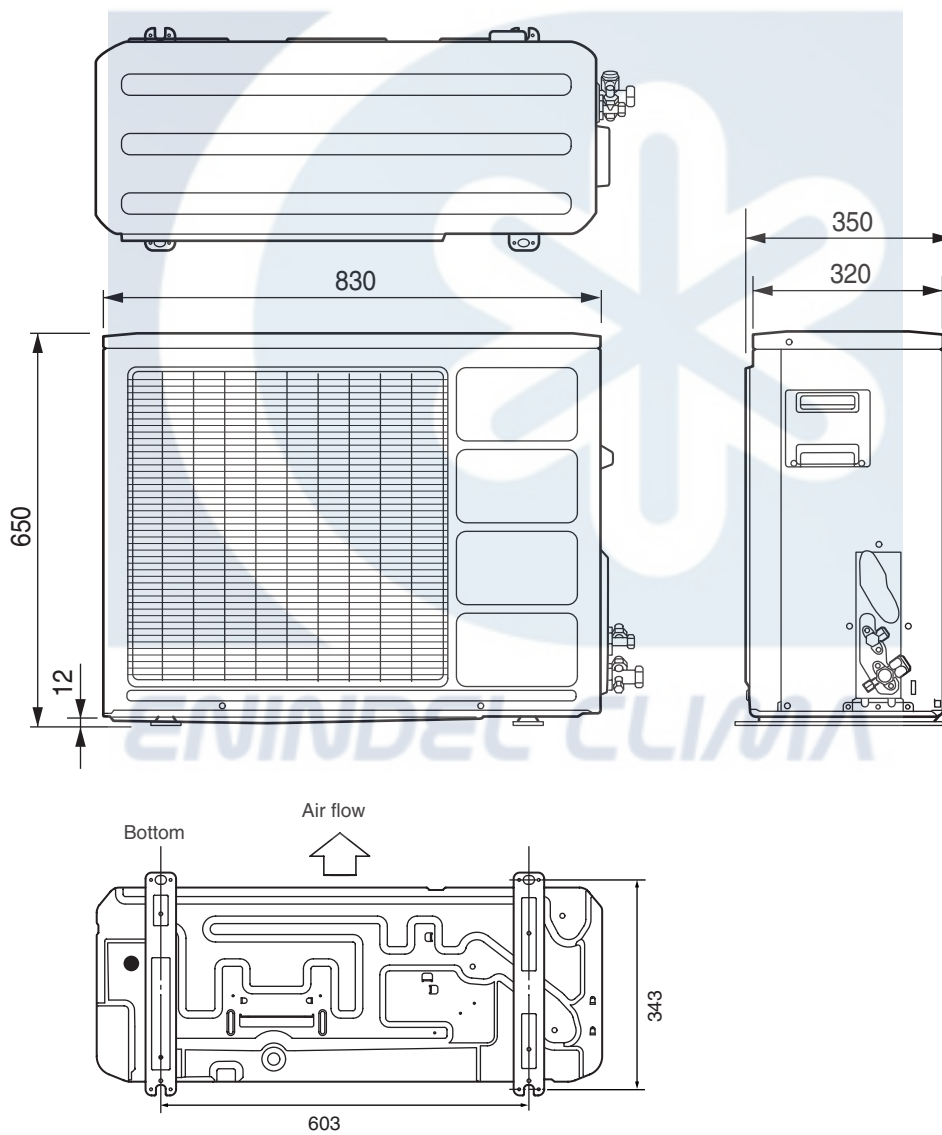

CIRCUIT DIAGRAM

Model : ARG25FUAA

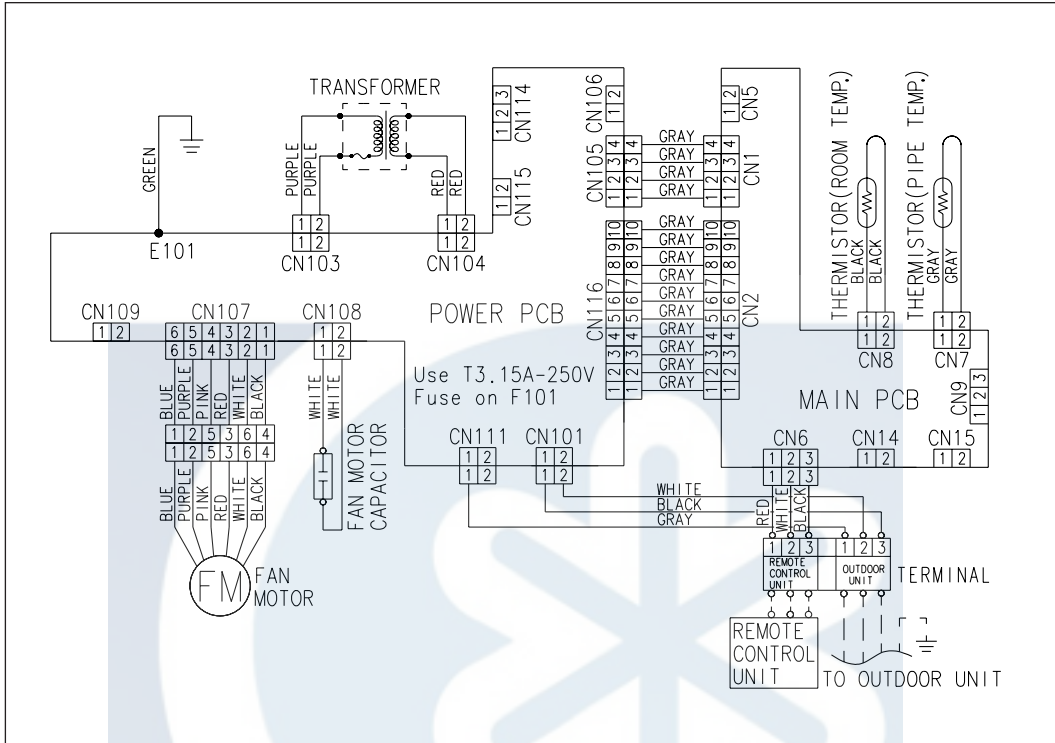

Model : AOG25FNAKL

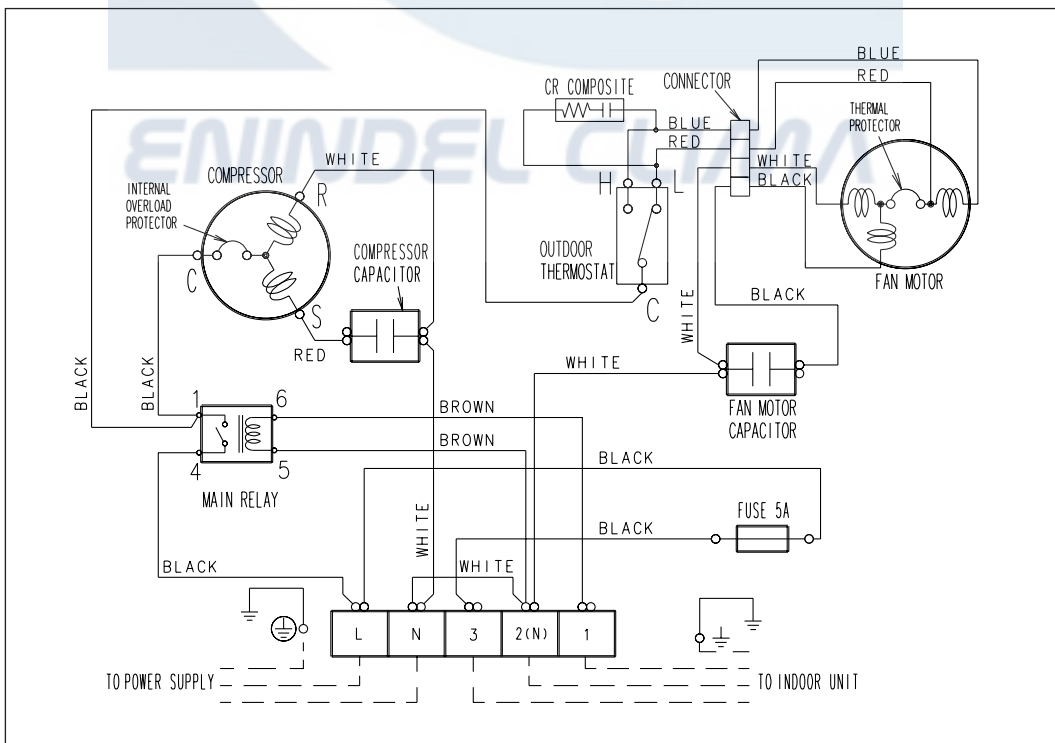

Model : ARG25UUA

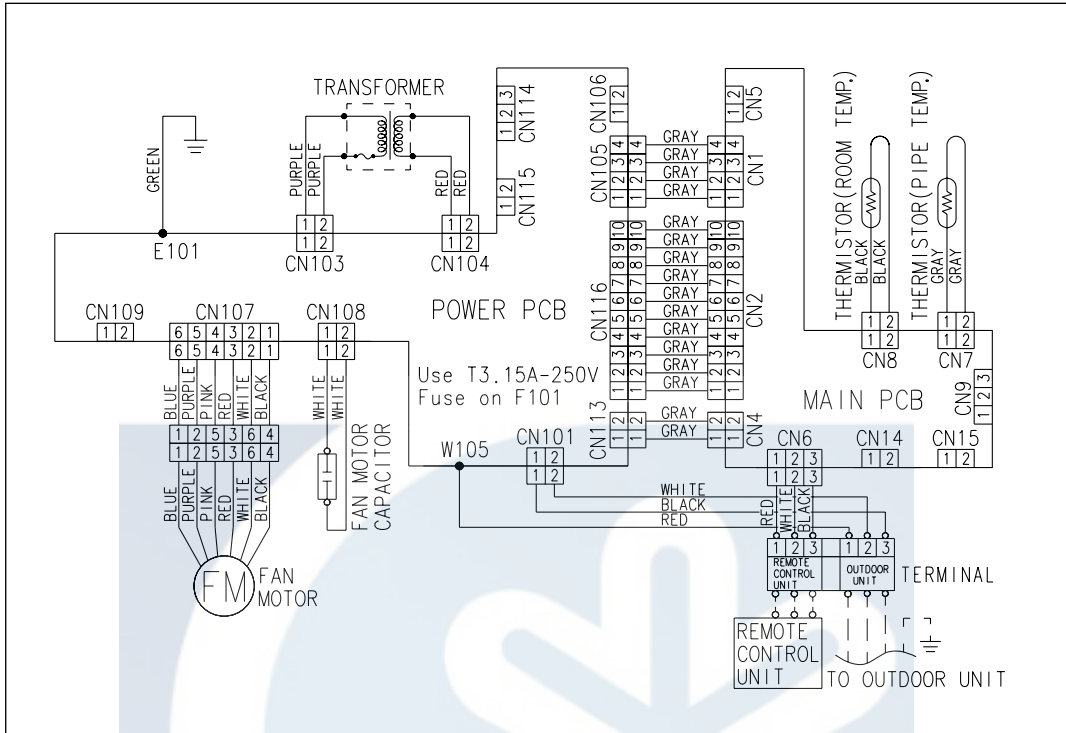

Model : AOG25UNAKL

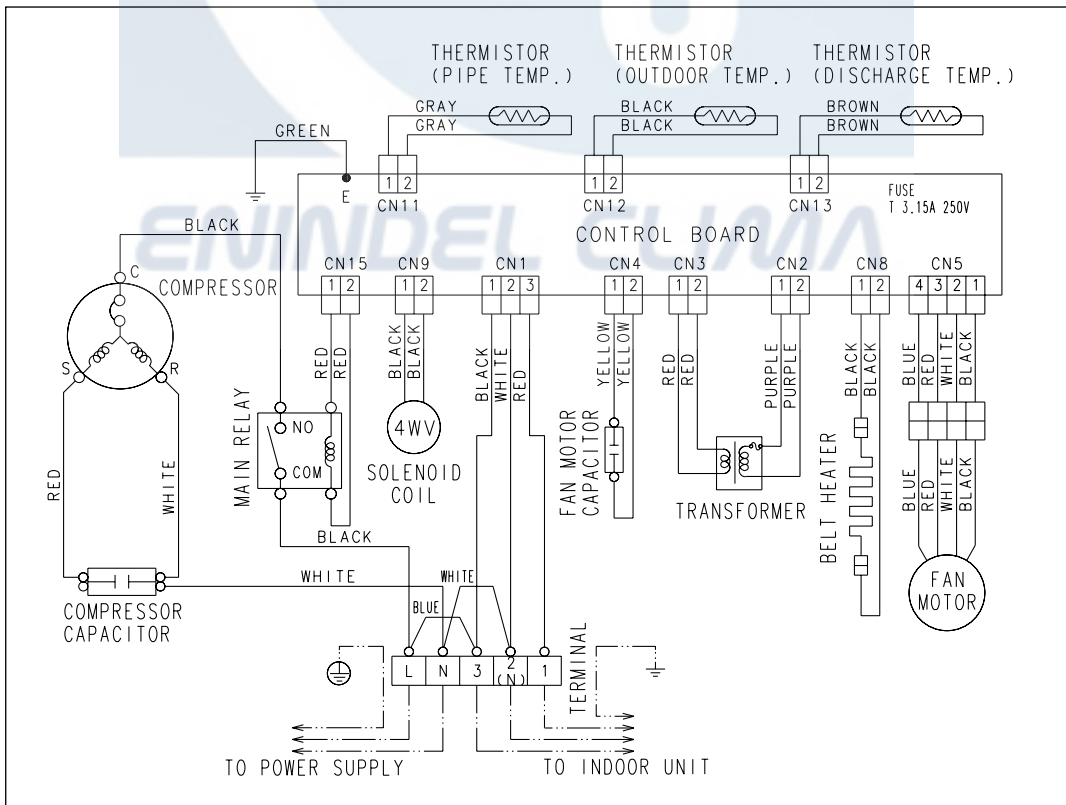

REFRIGERANT SYSTEM DIAGRAM

Models : ARG25FUAA / AOG25FNAKL

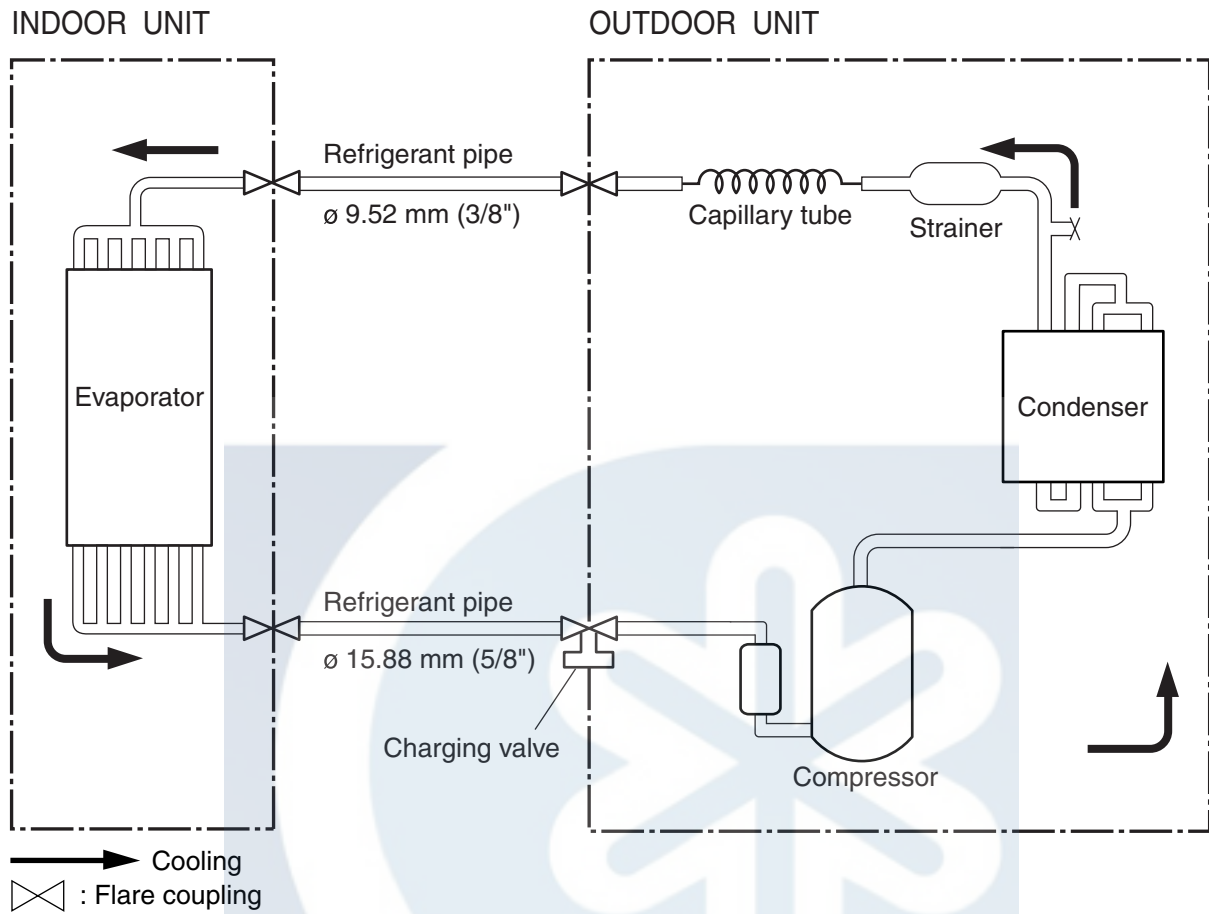

Models : ARY25UUAA / AOY25UNAKL

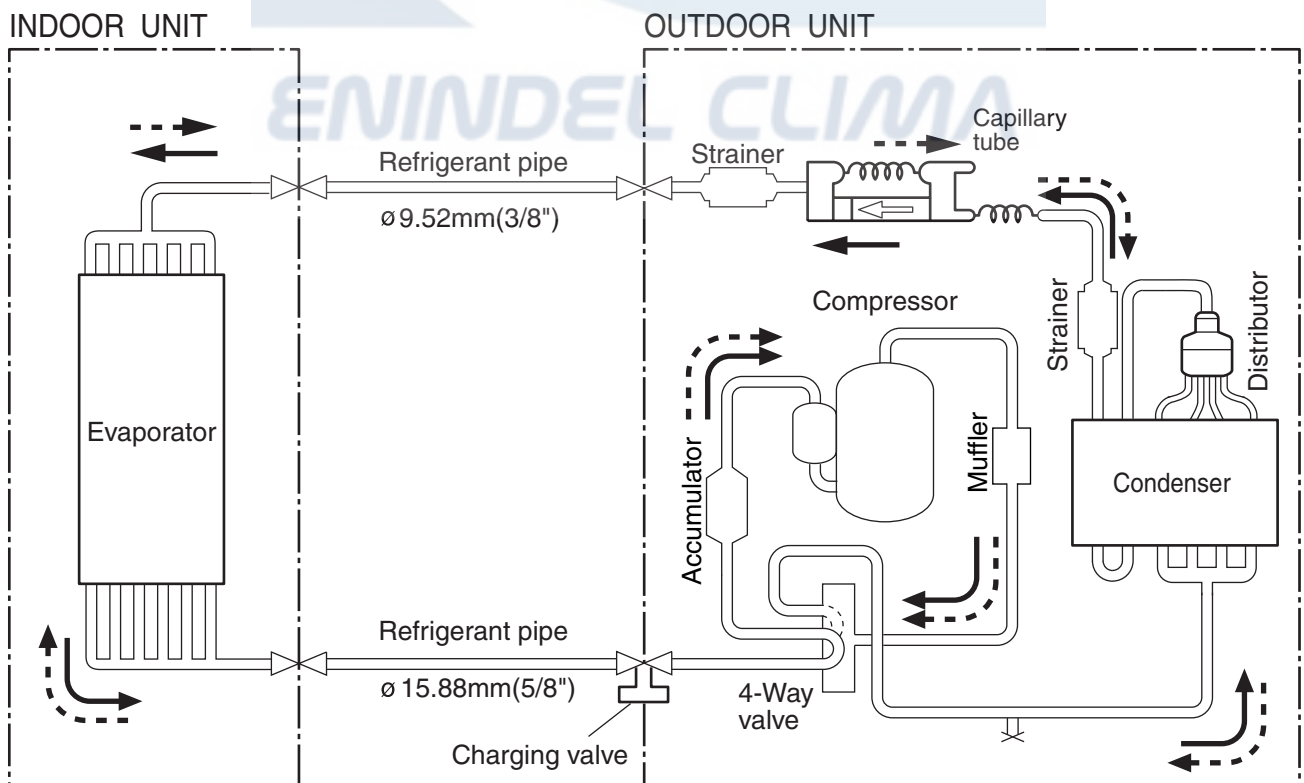

INDOOR PRINTED CIRCUIT BOARD CIRCUIT DIAGRAM

Model : ARG25FUAA

**POWER SUPPLY PCB
K03CA-0401WSE-P0**

**CONTROLLER PCB ASSEMBLY (MAIN PCB)
K03BZ-0403WSE-C1**

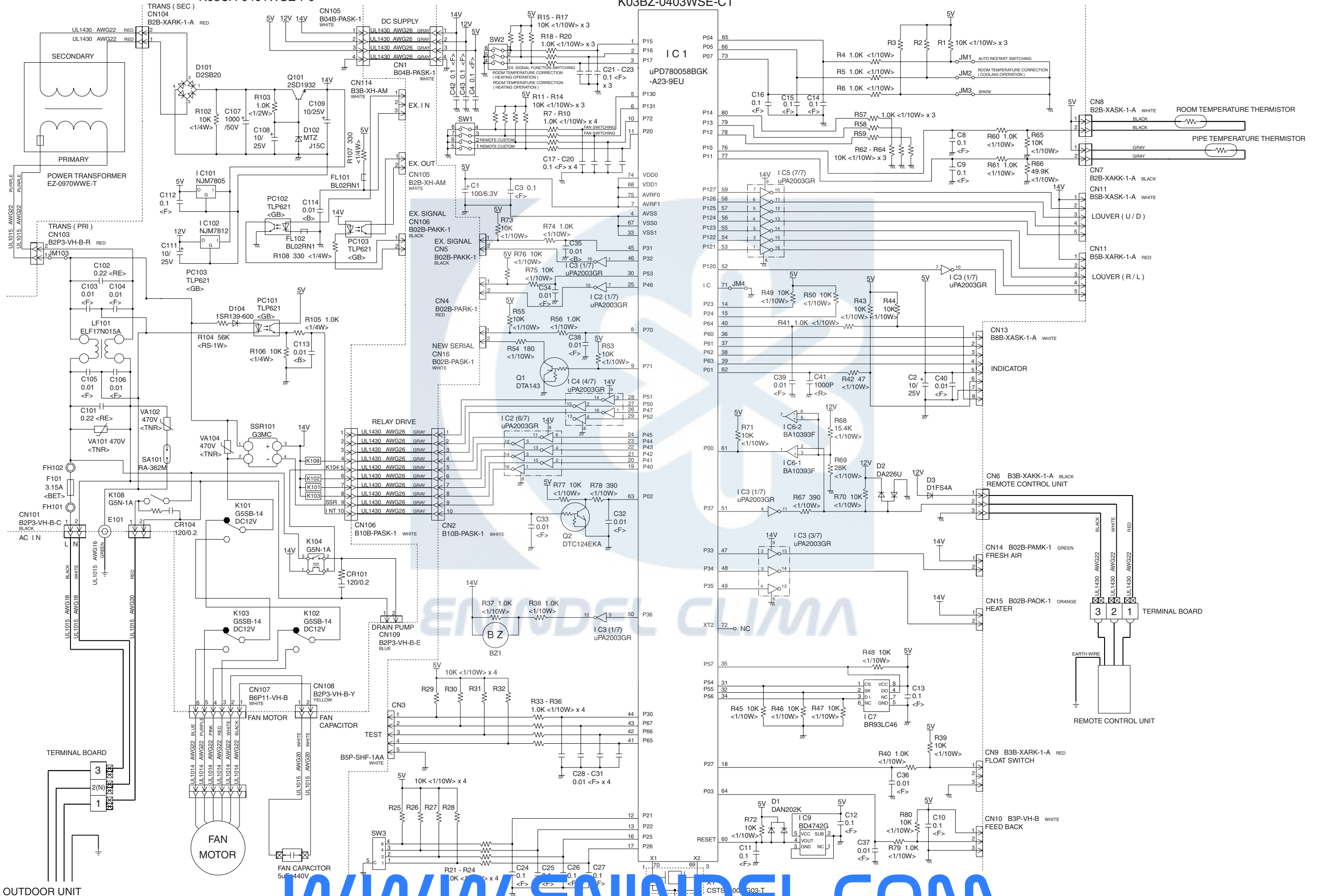

POWER SUPPLY PCB
K03CA-0400HSE-P0

CONTROLLER PCB ASSEMBLY (MAIN PCB)
K03BZ-0402HSE-C1

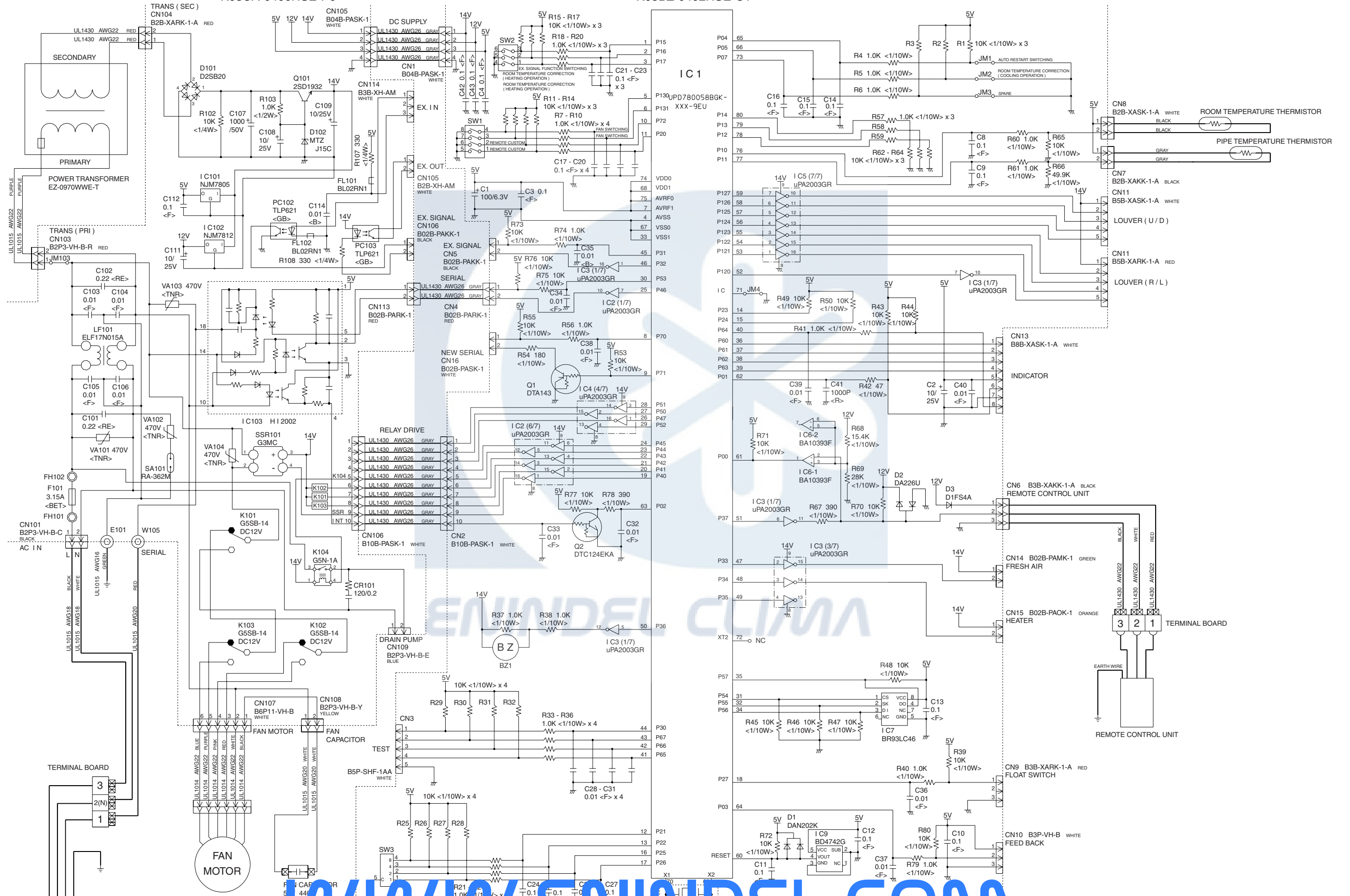

OUTDOOR PRINTED CIRCUIT BOARD CIRCUIT DIAGRAM

Model : AOG25UNAKL

CONTROLLER PCB ASSEMBLY (MAIN PCB)
K01D1-0400HUE-C1

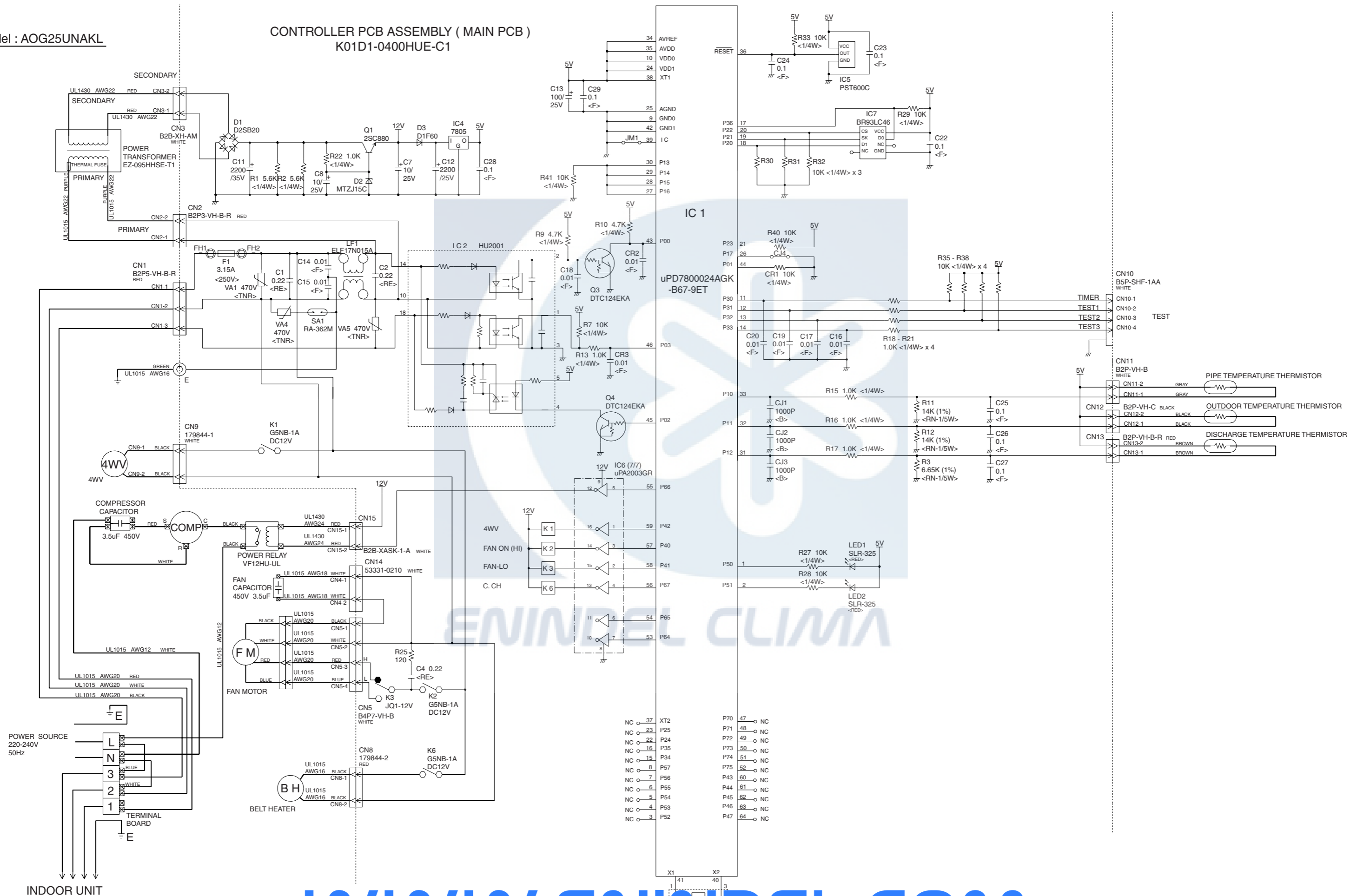

DISASSEMBLY ILLUSTRATION

Models : ARG25FUAA
ARG25UUAA

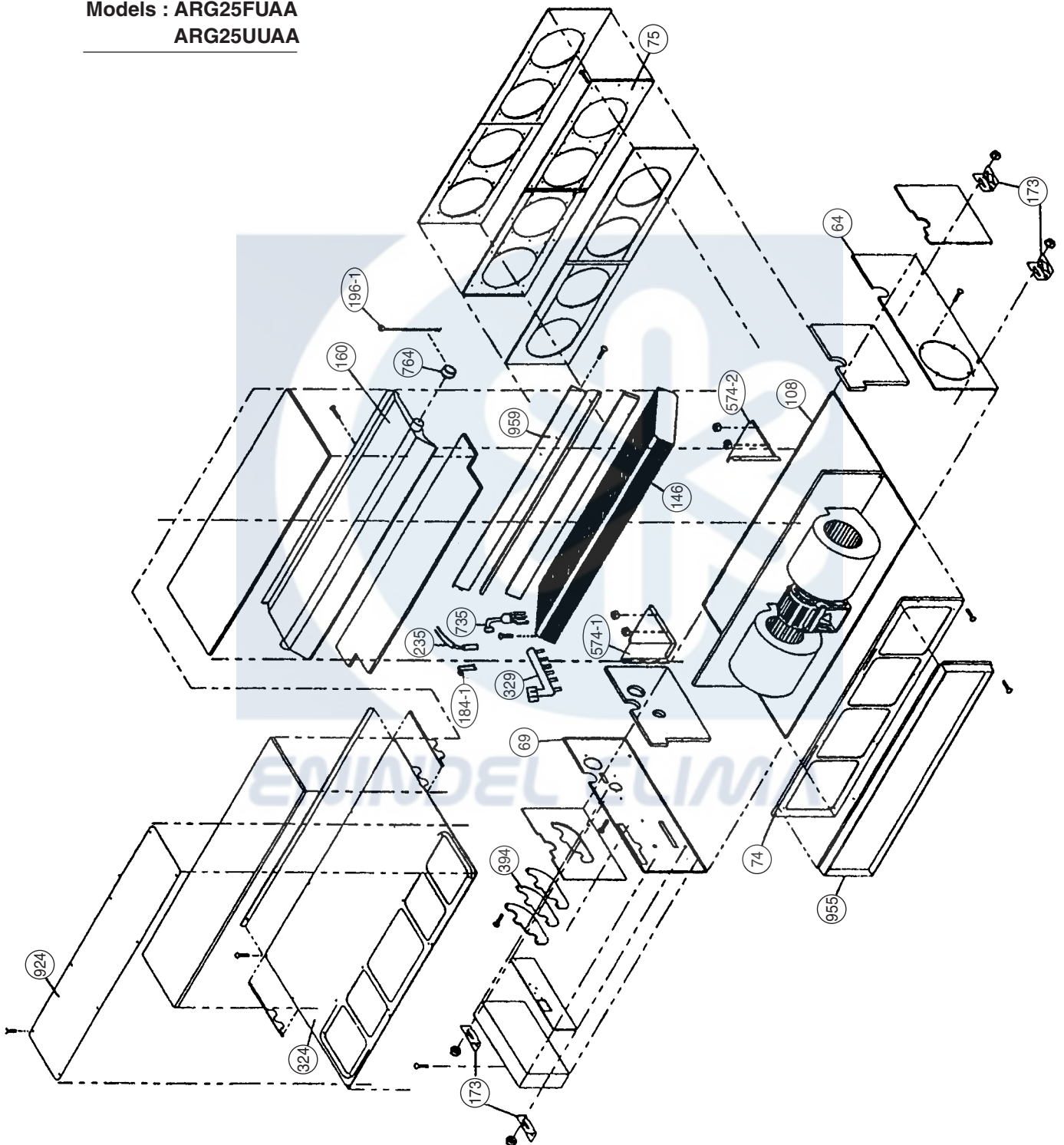

Models : ARG25FUAA
ARG25UUA

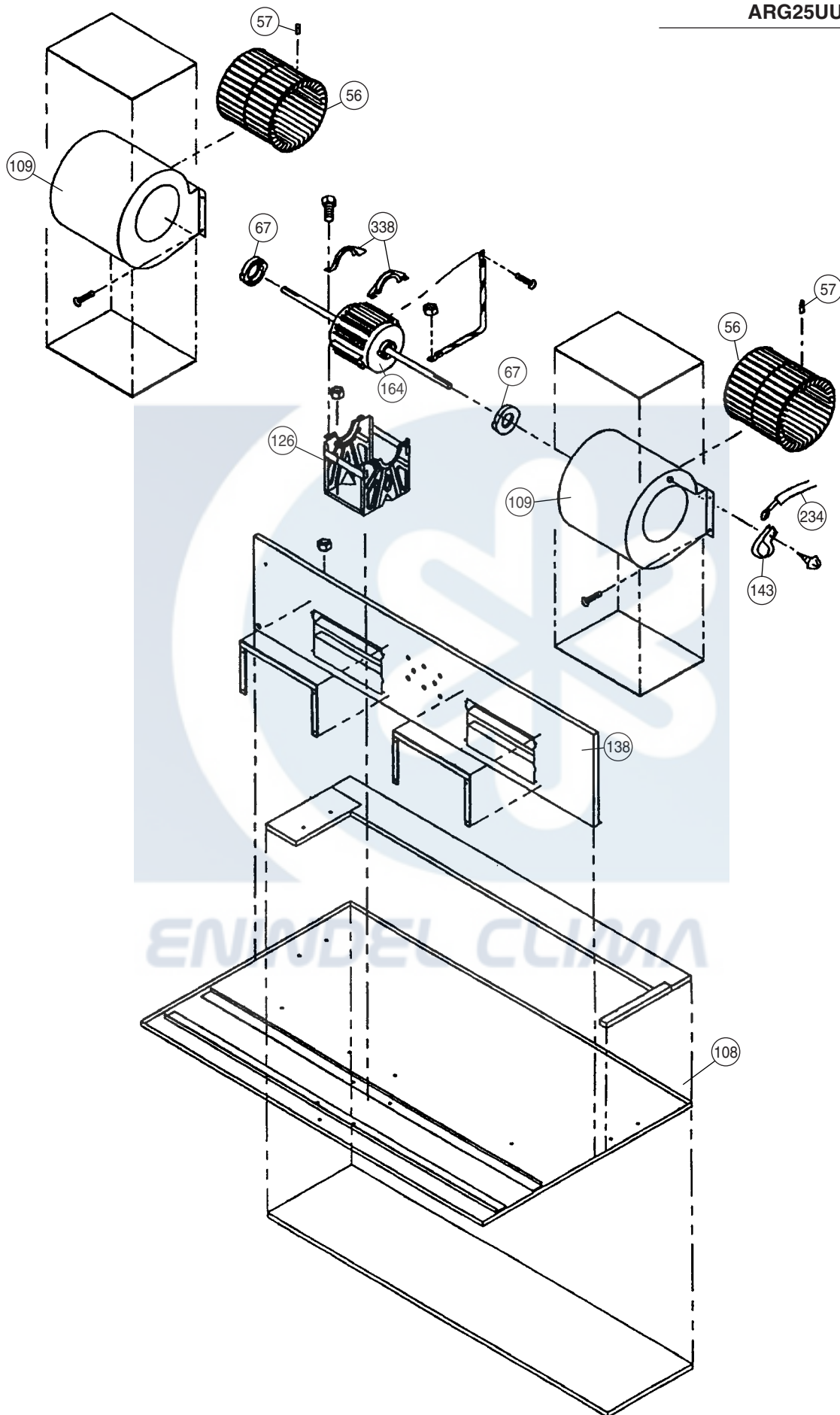

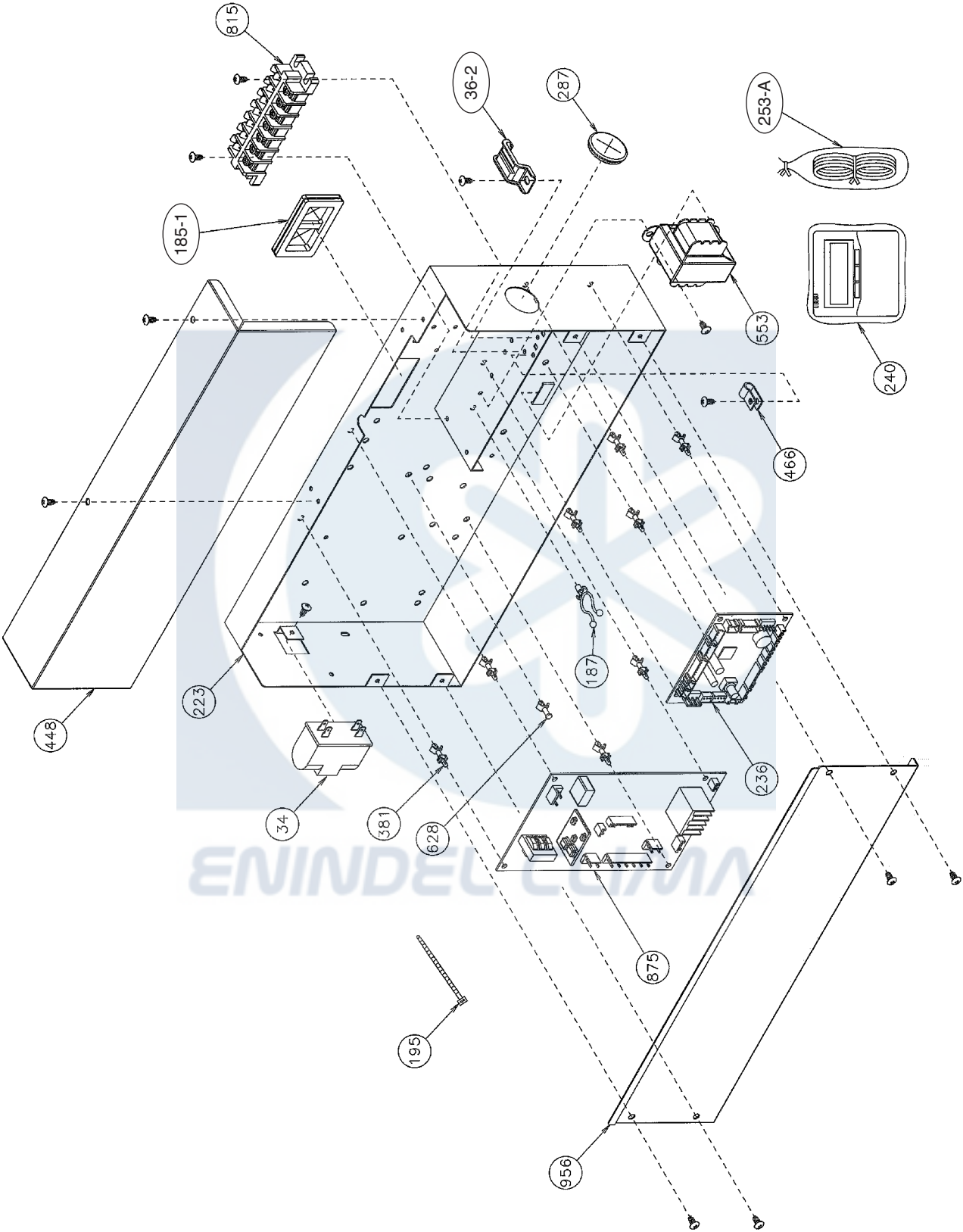

Models : AOG25FNAKL
AOG25UNAKL

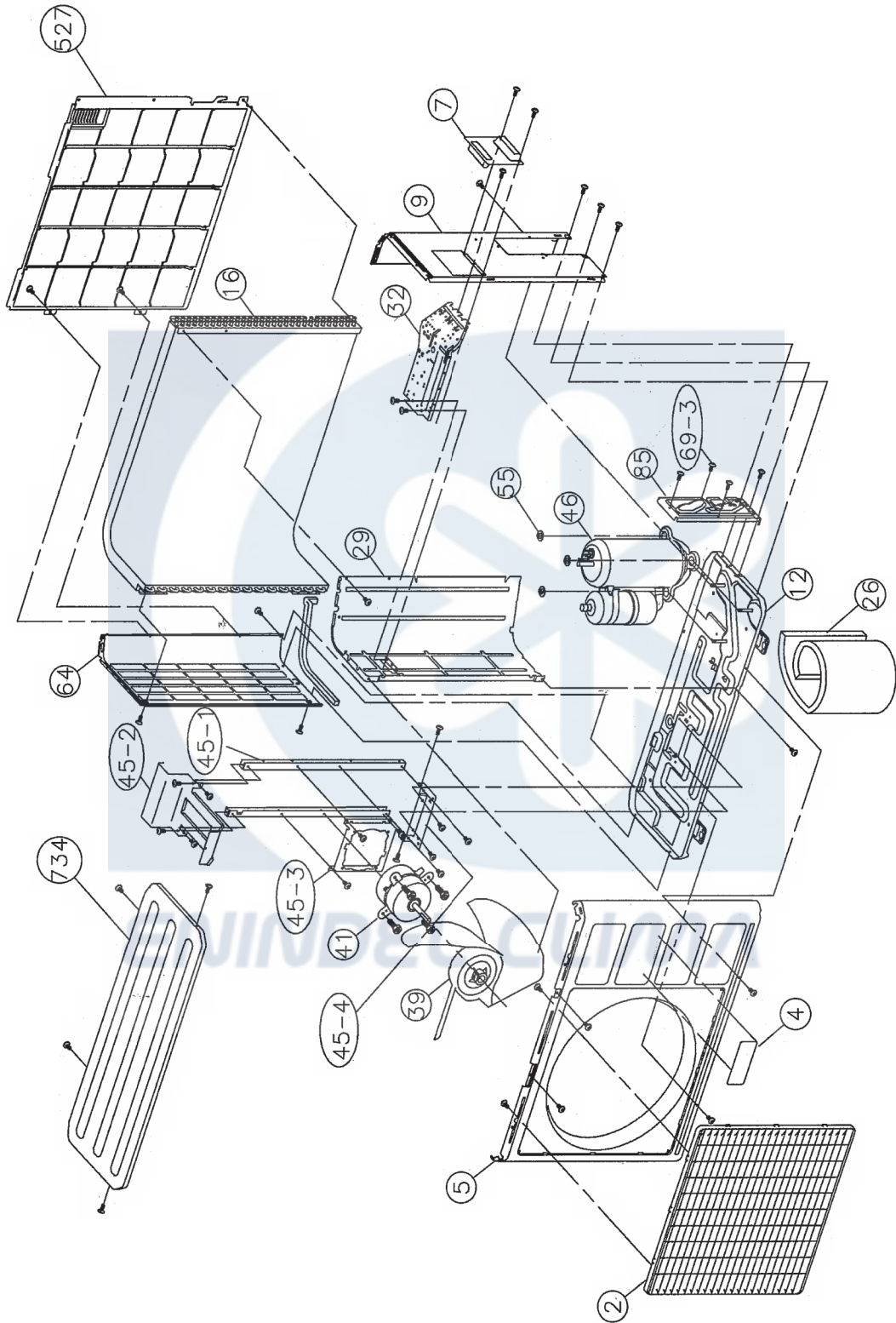

Model : AOG25FNAKL

Model : AOG25UNAKL

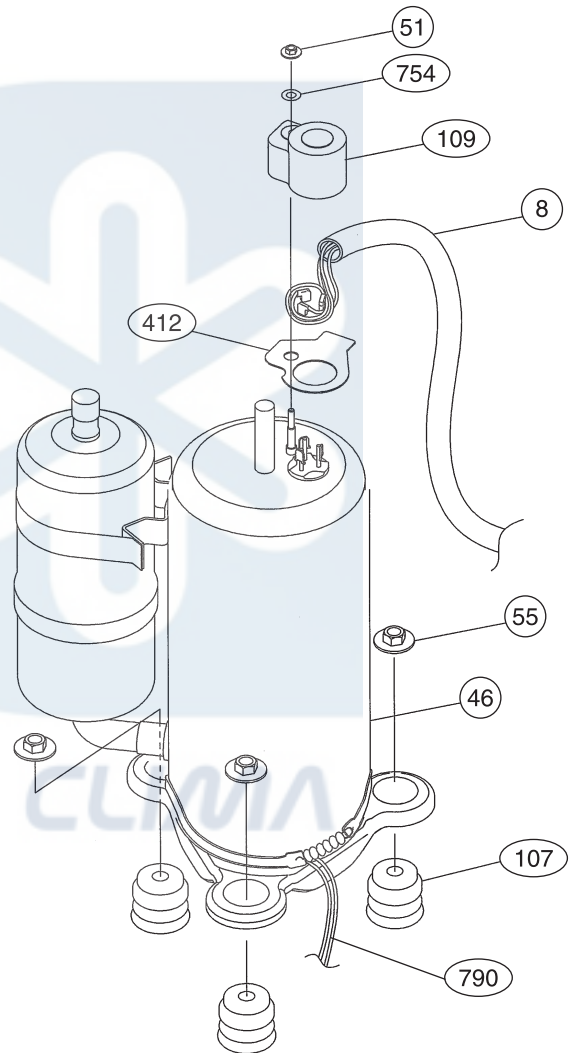
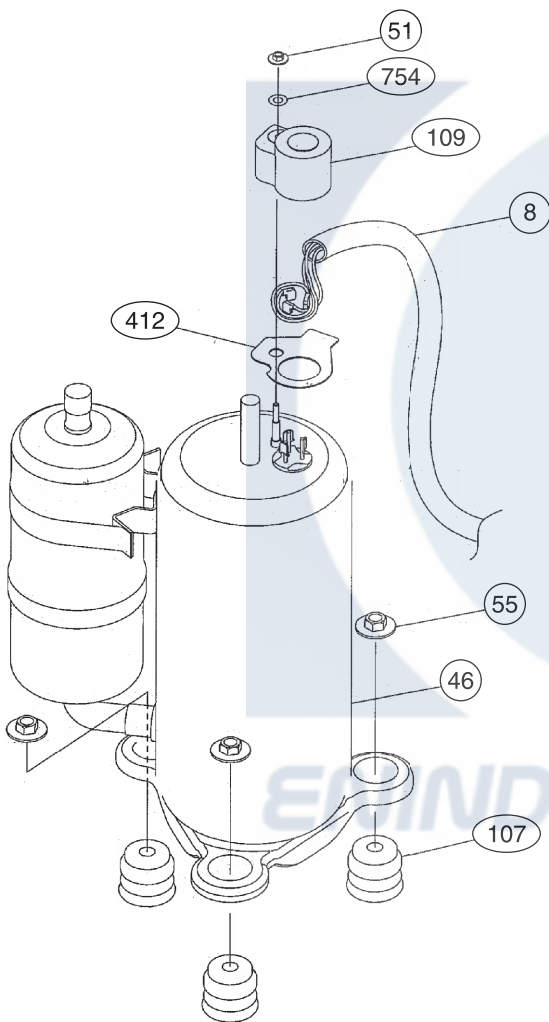

Model : AOG25FNAKL

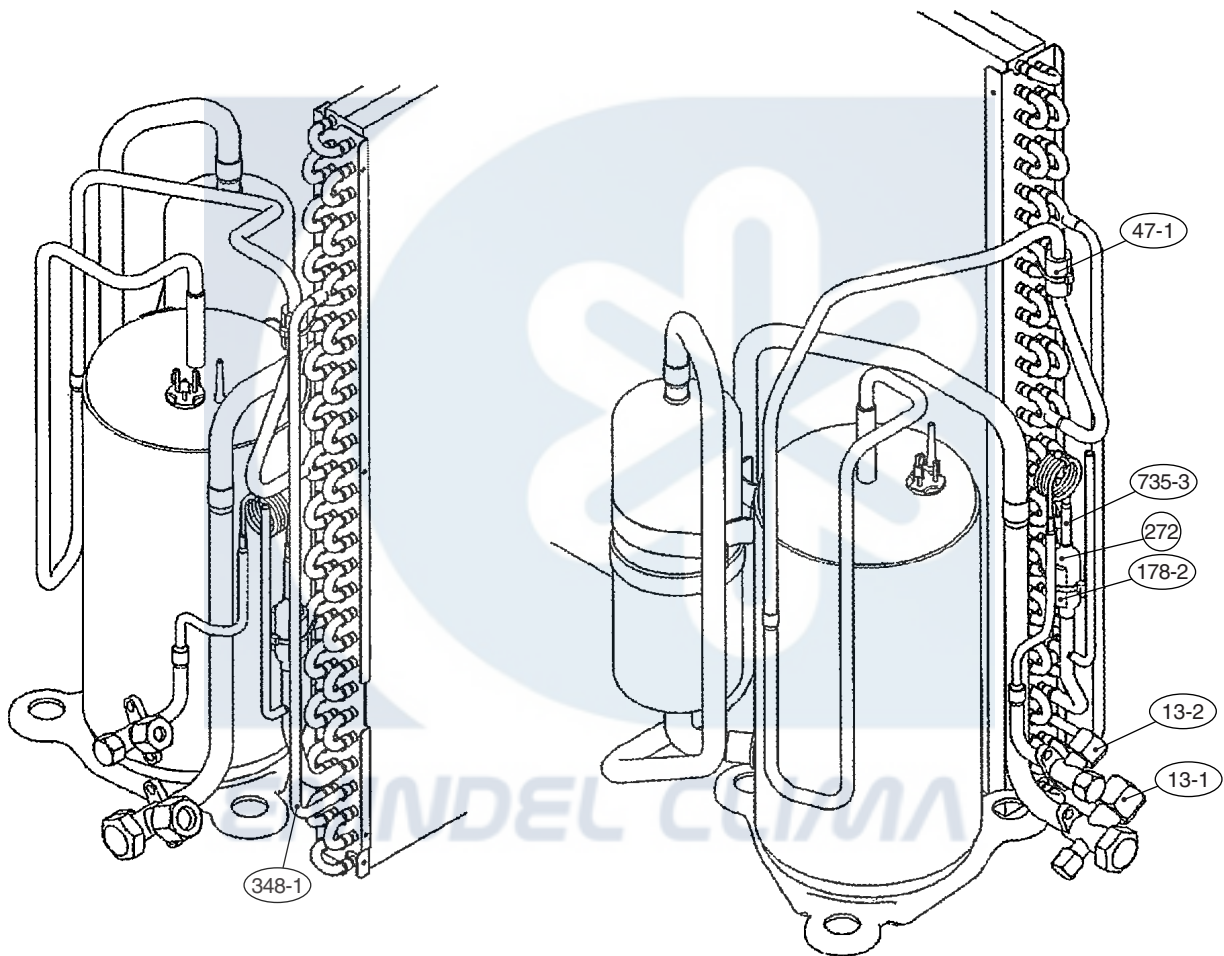

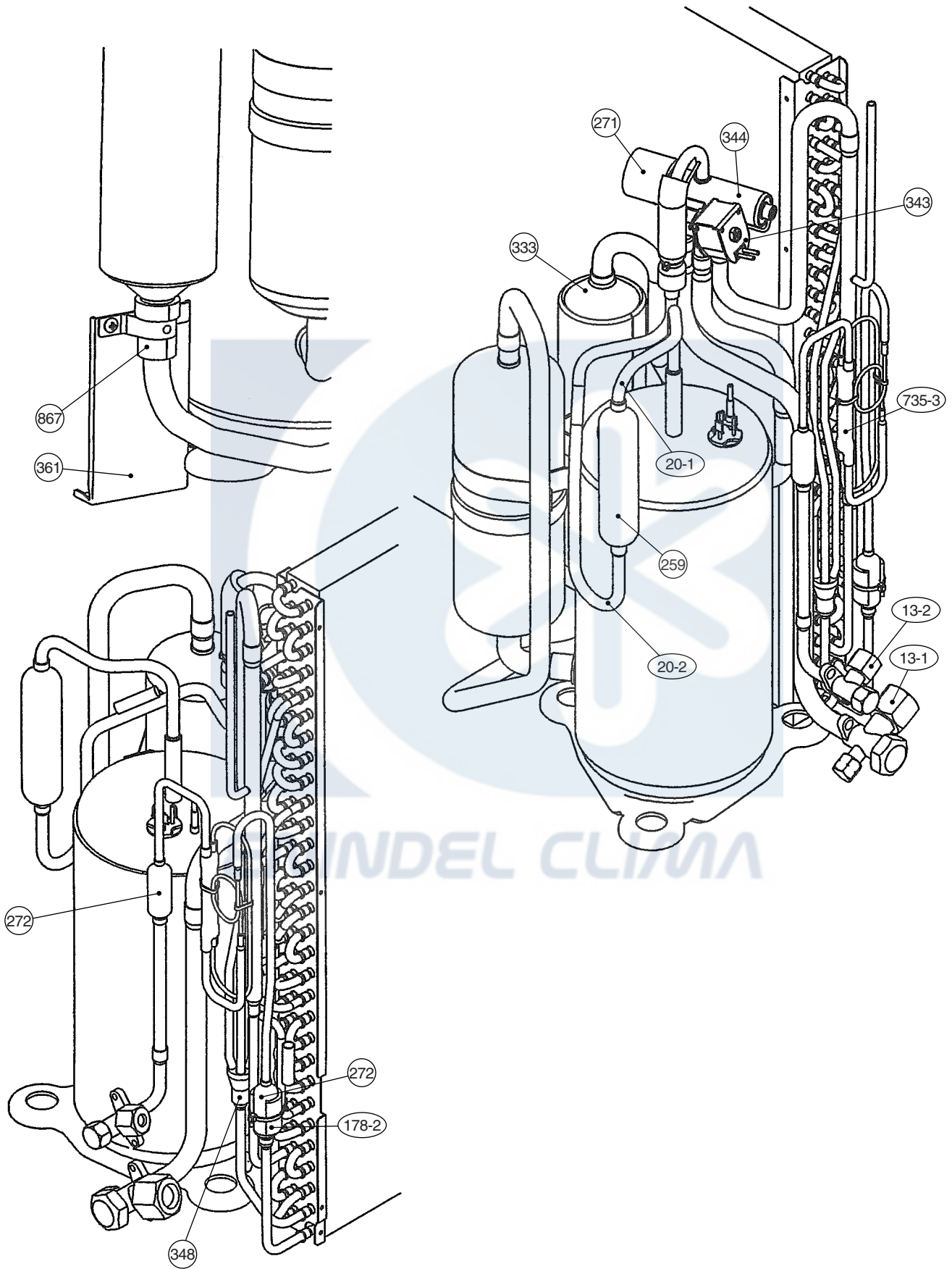

Model : AOG25FNAKL

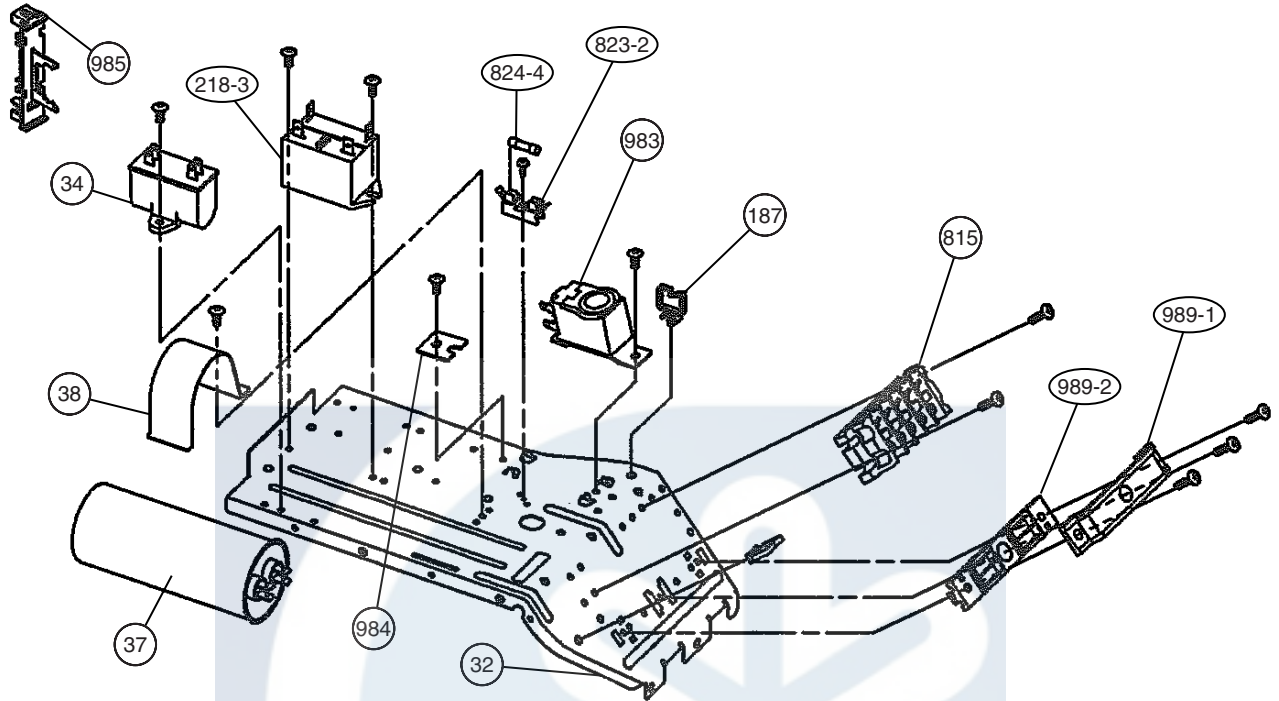

Model : AOG25UNAKL

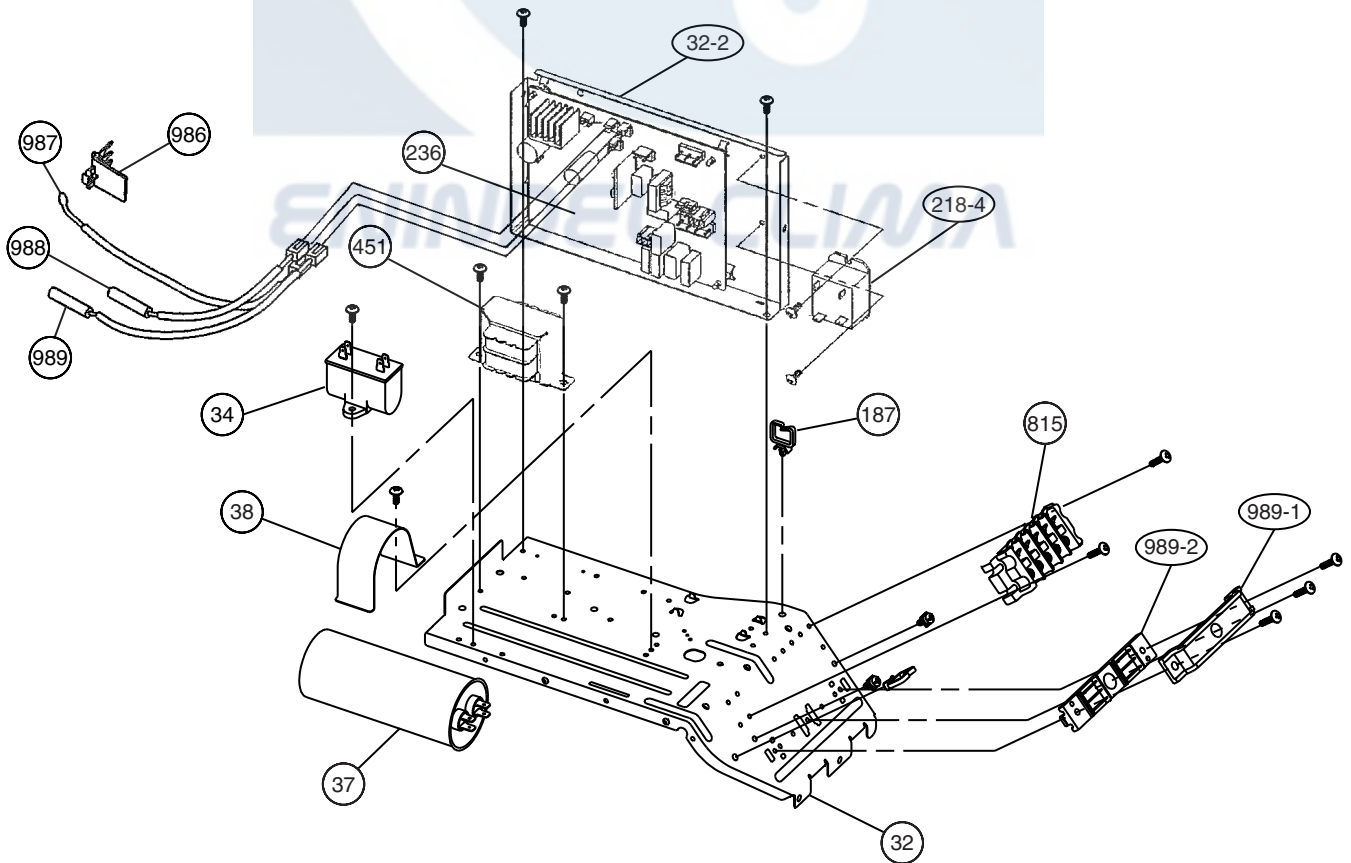

PARTS LIST

INDOOR UNIT

When you order parts, please make a photocopy of this page and fill the number of the parts in the "Order" column.











Ref. No.	Description	Part No.		Ord. Q'ty
		ARG25FUAA	ARG25UUAA	
34	Capacitor (Fan Motor)	9900230012	9900230012	
36-2	Cord Holder Metal	9356362008	9356362008	
56	Sirocco Fan Assy	9356531022	9356531022	
57	Hex. Socket Screw	313616213202	313616213202	
64	Cabinet-Left Metal	9356551006	9356551006	
67	Rubber (Vibration-proof)	313659068604	313659068604	
69	Cabinet-Right Metal	9356547009	9356547009	
74	Intake Panel	9356537000	9356537000	
75	Outlet Panel Assy	9356538007	9356538007	
108	Base Assy	9356518009	9356518009	
109	Casing Assy	9356527001	9356527001	
126	Motor Fixing Table Assy	9356533002	9356533002	
138	Separate Wall	9356523003	9356523003	
143	Clamp NK-3N	313361274700	313361274700	
146	Evaporator Assy	9373255048	9373255048	
160	Drain Pan Assy	9356542028	9356542028	
164	Fan Motor Assy-IN	9600830024	9600830024	
173	Hanger Bracket	9356563009	9356563009	
184-1	Thermo. Spring-A	313728262708	313728262708	
185-1	Rubber Bushing	9357376004	9357376004	
187	Clamp No. 1219	313361271706	313361271706	
195	Clamp SKB-100	313361275805	313361275805	
196-1	Clamp SKB-3M	312300787605	312300787605	
223	Control Box Metal Assy	9373905011	9373905011	
234	Thermistor Assy	9703299056	9703299056	
235	Thermistor Assy-Pipe	9703297045	9703297045	
236	Controller PCB Assy	9705246065 (K03BZ-0403WSE-C1)	9705246058 (K03BZ-0402HSE-C1)	
240	Remote Control Unit	9372266021	9372266014	
253-A	Wire Assy	9372714010	9372714010	
287	Cap (Power)	9352173011	9352173011	
324	Top Plate	9356546002	9356546002	
329	Coupling Pipe Assy	9371333021	9371333021	
338	Motor Fixture	9356536003	9356536003	
381	Loking Spacer	313209391506	313209391506	
394	Pipe Fixing Plate	9356554007	9356554007	
448	Control Box Metal-B	9356560008	9356560008	
466	Clamp NK-4N	313714328805	313714328805	
574-1	Eva. Fixing Plate-R	9356521009	9356521009	
553	Transformer (Power)	9704129017	9704129017	
574-2	Eva. Fixing Plate-L	9356522006	9356522006	
628	Locking Spacer B	313005446558	313005446558	
735	Distributor Assy	9371325026	9371325026	
764	Drain Cap	9356541007	9356541007	
815	Terminal-7P	9703403019	9703403019	
875	Filter PCB Assy	9705271043	9705271036	
924	Intake Seal Plate	9356553000	9356553000	
955	Square Flange Assy	9356555004	9356555004	
956	Control Box Metal-E	9356900002	9356900002	
959	Eva. Seal Plate	9356540000	9356540000	

OUTDOOR UNIT

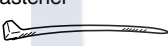

Ref. No.	Description	Part No.	Ord. Q'ty	Ref. No.	Description	Part No.	Ord. Q'ty
		AOG25FNAKL				AOG25UNAKL	
2	Fan Guard	9371187013		2	Fan Guard	9371187013	
4	Emblem-Rear	9372171011		4	Emblem-Rear	9372171011	
5	Front Panel Ptd	9371924014		5	Front Panel Ptd	9371924014	
7	Connector Cover (Cabinet)	9366398004		7	Connector Cover (Cabinet)	9366398004	
8	Wire Assy (Comp)	9372334010		8	Wire Assy (Comp)	9372334010	
9	Side Panel R Ptd	9371927015		9	Side Panel R Ptd	9371927015	
12	Base Assy, Ptd	9371920016		12	Base Assy, Ptd	9371920016	
13-1	3-Way Valve Assy	9372205013		13-1	3-Way Valve Assy	9372205013	
13-2	2-Way Valve Assy	9372204023		13-2	2-Way Valve Assy	9372204023	
16	Condenser Assy	9372181027		16	Condenser Assy	9372181010	
26	Compressor Cover A	9372327012		26	Compressor Cover A	9372327012	
29	Separate Wall	9371933016		29	Separate Wall	9371933023	
32	Control Box	9371935016		32	Control Box	9371935010	
34	Capacitor, Plastic	9900130022		32-2	Control Box B	9371936017	
37	Running Capacitor	9703107023		34	Capacitor, Plastic	9900130022	
38	Capacitor Clamp Metal	313791061807		37	Running Capacitor	9703107023	
39	Propeller Fan Assy	9366378013		38	Capacitor Clamp Metal	313791061807	
41	Motor Induct	9601671046		39	Propeller Fan Assy	9366378013	
45-1	Motor Bracket	9371929019		41	Motor Induct	9601671046	
45-2	Motor Bracket-Top	9371931012		45-1	Motor Bracket	9371929019	
45-3	Motor Bracket Ctr	9371930015		45-2	Motor Bracket-Top	9371931012	
45-4	Motor Bracket Bottom	9371932019		45-3	Motor Bracket Ctr	9371930015	
46	Compressor Assy	9372558010		45-4	Motor Bracket Bottom	9371932019	
47-1	Rubber (Discharge Pipe)	313194159807		46	Compressor Assy	9372558010	
51	Special Nut M5	9300301015		47-1	Rubber (Discharge Pipe)	313194159807	
55	Special Nut M8	9355091008		51	Special Nut M5	9300301015	
64	Side Panel L Ptd	9371926018		55	Special Nut M8	9355091008	
69-3	Bolt, Hex. Socket	301210060360		64	Side Panel L Ptd	9371926018	
85	Valve Plate Ptd	9371928012		69-3	Bolt, Hex. Socket	301210060360	
107	Rubber Seat-A	9351049010		85	Valve Plate Ptd	9371928012	
109	Terminal Cover (Comp)	9371511016		107	Rubber Seat-A	9351049010	
178-2	Capillary Holder Rubber	313394274808		109	Terminal Cover (Comp)	9371511016	
187	Clip (Cable)	9352715006		178-2	Capillary Holder Rubber	313394274808	
218-3	Relay	9900074012		187	Clip (Cable)	9352715006	
272	Strainer	9369287008		218-4	Power Relay	9353611017	
348-1	Outlet Pipe (Cond)	9372190029		236	PCB Assy	9704299062	
412	Cover Gasket (Comp.)	9371512013		259	Muffler	9372369012	
527	Protectiive Net	9371934013		271	4-Way Valve Rubber	313728251908	
734	Top Panel	9371925011		272	Strainer	9369287008	
735-3	Capillary Assy	9372197059		333	Accumulator	9368391003	
754	Terminal Gask. Washer	9351053017		348	Outlet pipe (cond) assy	9372189016	
815-3	Terminal-5P	9900203023		343	Solenoid	9900165024	
823-2	Fuse Holder	0500063024		344	4-Way Valve	9900163013	
824-4	Fuse	0600222529		361	Accum Support Assy	9372252017	
982-1	Cord Clamp-A	9359822011		412	Cover Gasket (Comp.)	9371512013	
982-2	Cord Clamp-B	9359823018		451	TRANSFORMER	9900039011	
983	Outdoor Thermostat	9352553004		527	Protectiive Net	9371934013	
984	Bracket (switch)	313986353607		734	Top Panel	9371925011	
985	Bracket (thermostat)	9372643013		735-3	Capillary Assy	9372197288	
				754	Terminal Gask. Washer	9351053017	
				790	Belt Heater	9361140165	
				815-3	Terminal-5P	9900203023	
				823-2	Fuse Holder	0500158072	
				824-4	Fuse	0600222512	
				867	Accumulator Holder Rubber	9354022010	
				982-1	Cord Clamp-A	9359822011	
				982-2	Cord Clamp-B	9359823018	
				986	Bracket (thermo)	9373154013	
				987	Outdoor Temp thermistor	9900037031	
				988	Discharge Temp thermistor	9900038014	
				989	Heat Exchanger thermistor	9900043032	

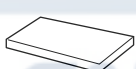
STANDARD ACCESSORIES

INDOOR UNIT ACCESSORIES

Name and Shape	Q'ty	Application	Part No.	
			ARG25FUAA	ARG25UUAA
Installation template 	1	For positioning the indoor unit	9357036007	9357036007
Hanger 	4	For suspending the indoor unit from ceiling	9356563009	9356563009
Special nut A (large flange) 	4	For suspending the indoor unit from ceiling	313005446653	313005446653
Special nut B (small flange) 	4		313005446759	313005446759
Coupler heat insulation (large) 	2	For indoor side pipe joint (large pipe)	9350716029	9350716029
Coupler heat insulation (small) 	1	For indoor side pipe joint (small pipe)	9352766015	9352766015
Nylon fastener 	1	For fixing the drain hose	312300787605	312300787605
Remote control unit 	1		9372266021	9372266014
Tapping screw 	2	For installing the remote control unit cord clamp	0700181108	0700181108
Drain hose insulation 	1	Insulates the drain hose and vinyl hose connection	313806217708	313806217708
Remote controller cord 	1		9372714010	9372714010

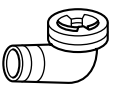
OUTDOOR UNIT ACCESSORIES

Name and Shape	Q'ty	Part No.	
		AOG25FNAKL	AOG25UNAKL
Drain pipe 	1	—	9303029015
Drain cap 	1	—	313166024302

