

Refrigerant R410A

Floor Console/Under Ceiling Dual Type INSTALLATION INSTRUCTION SHEET

(PART NO. 9373067016)

- WARNING** This mark indicates procedures which, if improperly performed, might lead to the death or serious injury of the user.
- CAUTION** This mark indicates procedures which, if improperly performed, might possibly result in personal harm to the user, or damage to property.

This air conditioner uses new refrigerant HFC (R410A).

The basic installation work procedures are the same as conventional refrigerant (R22) models. However, pay careful attention to the following points:

- Since the working pressure is 1.6 times higher than that of conventional refrigerant (R22) models, some of the piping and installation and service tools are special. (See the table below.) Especially, when replacing a conventional refrigerant (R22) model with a new refrigerant R410A model, always replace the conventional piping and flare nuts with the R410A piping and flare nuts.
- Models that use refrigerant R410A have a different charging port thread diameter to prevent erroneous charging with conventional refrigerant (R22) and for safety. Therefore, check beforehand. (The charging port thread diameter for R410A is 1/2 UNF 20 threads per inch.)
- Be more careful that foreign matter (oil, water, etc.) does not enter the piping than with refrigerant (R22) models. Also, when storing the piping, securely seal the openings by pinching, taping, etc.
- When charging the refrigerant, take into account the slight change in the composition of the gas and liquid phases, and always charge from the liquid phase side whose composition is stable.

Special tools for R410A

| Tool name | Contents of change |
|----------------------|---|
| Gauge manifold | Pressure is high and cannot be measured with a conventional gauge. To prevent erroneous mixing of other refrigerants, the diameter of each port has been changed. It is recommended the gauge with scale -0.1 to 5.3 MPa (-0.76 cmHg to 53 kgf/cm ²) for high pressure. -0.1 to 3.8 MPa (-0.76 cmHg to 38 kgf/cm ²) for low pressure. |
| Charge hose | To increase pressure resistance, the hose material and base size were changed. |
| Vacuum pump | A conventional vacuum pump can be used by installing a vacuum pump adapter. |
| Gas leakage detector | Special gas leakage detector for HFC refrigerant R410A. |

Copper pipes

It is necessary to use seamless copper pipes and it is desirable that the amount of residual oil is less than 40 mg/10 m. Do not use copper pipes having a collapsed, deformed or discolored portion (especially on the interior surface). Otherwise, the expansion valve or capillary tube may become blocked with contaminants. As an air conditioner using R410A incurs pressure higher than when using R22, it is necessary to choose adequate materials. Thicknesses of copper pipes used with R410A are as shown in Table 1. Never use copper pipes thinner than 0.8 mm (Nominal diameter is 1/4 in., 3/8 in., 1.0 mm (Nominal diameter is 5/8 in.) even when it is available on the market.

Table 1 Thicknesses of Annealed Copper Pipes

| Nominal diameter (inch) | Outer diameter (mm) | Thickness (mm) | |
|-------------------------|---------------------|----------------|------------|
| | | R410A | [ref.] R22 |
| 1/4 | 6.35 | 0.80 | 0.80 |
| 3/8 | 9.52 | 0.80 | 0.80 |
| 5/8 | 15.88 | 1.00 | 1.00 |

For authorized service personnel only.

- WARNING**
- (1) For the room air conditioner to operate satisfactorily, install it as outlined in this installation instruction sheet.
- (2) Connect the indoor unit and outdoor unit with the room air conditioner piping and cords available standards parts. This installation instruction sheet describes the correct connections using the installation set available from our standard parts.
- (3) Installation work must be performed in accordance with national wiring standards by authorized personnel only.
- (4) If refrigerant leaks while work is being carried out, ventilate the area. If the refrigerant comes in contact with a flame, it produces a toxic gas.
- (5) Do not use an extension cord.
- (6) Do not turn on the power until all installation work is complete.
- Be careful not to scratch the room air conditioner when handling it.
- After installation, explain correct operation to the customer, using the operating manual.
- Let the customer keep this installation instruction sheet because it is used when the air conditioner is serviced or moved.

SELECTING THE MOUNTING POSITION

- WARNING**
- Install at a place that can withstand the weight of the indoor and outdoor units and install positively so that the units will not topple or fall.
- CAUTION**
- (1) Do not install where there is the danger of combustible gas leakage.
- (2) Do not install near heat sources.
- (3) If children under 10 years old may approach the unit, take preventive measures so that they cannot reach the unit.

Decide the mounting position with the customer as follows:

1. INDOOR UNIT

- Install the indoor unit level on a strong wall, floor, ceiling which is not subject to vibration.
- The inlet and outlet ports should not be obstructed: the air should be able to blow all over the room.
- Install the unit near an electric outlet or special branch circuit.
- Do not install the unit where it will be exposed to direct sunlight.
- Install the unit where connection to the outdoor unit is easy.
- Install the unit where the drain pipe can be easily installed.
- Take servicing, etc. into consideration and leave the spaces shown in Fig. 1. Also install the unit where the filter can be removed.

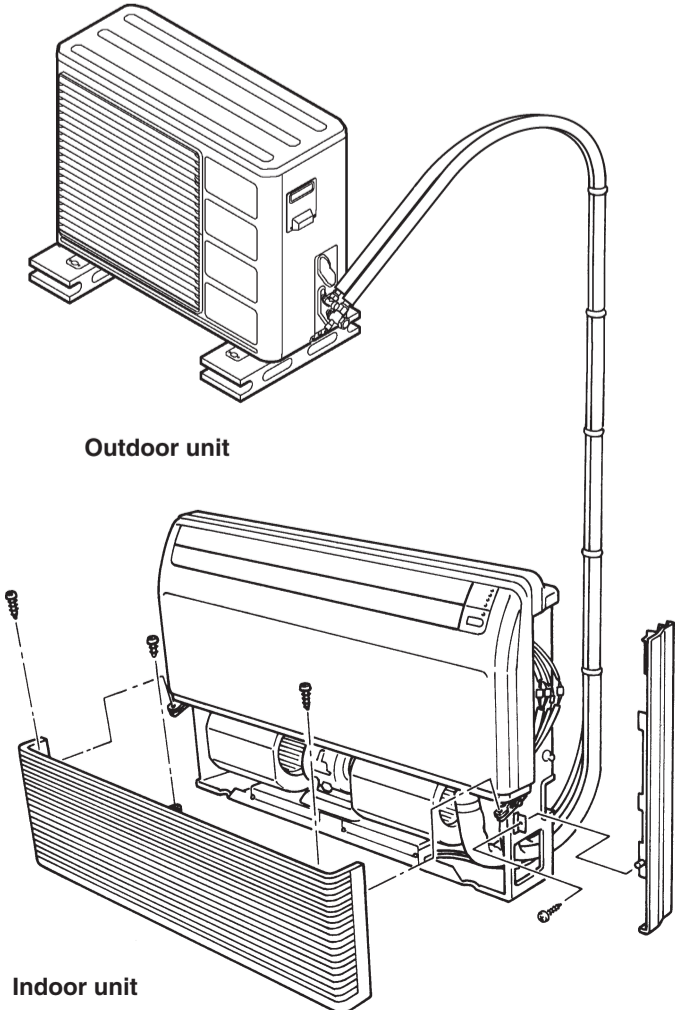
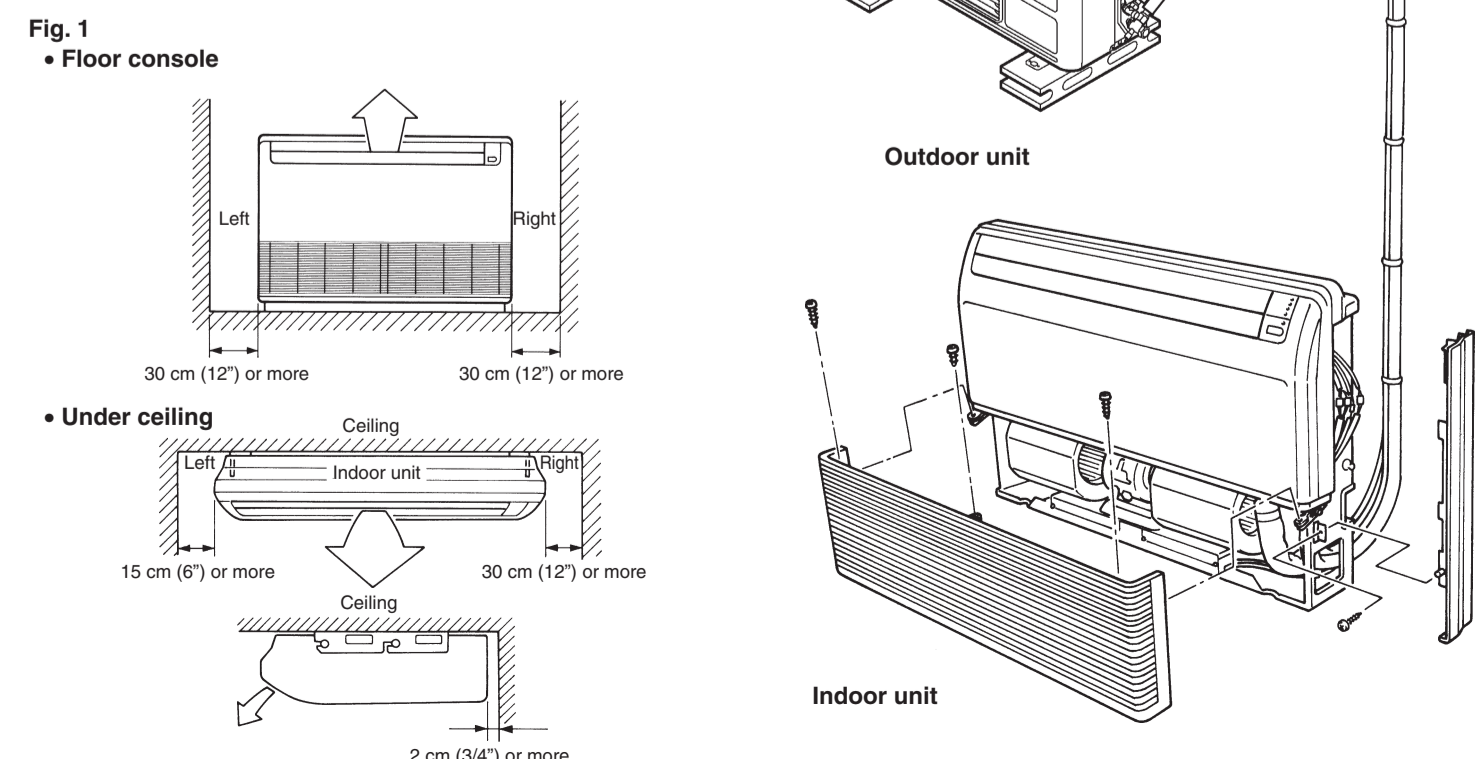

STANDARD PARTS

The following installation parts are furnished. Use them as required.
INDOOR UNIT ACCESSORIES

| Name and Shape | Q'ty | Application |
|--------------------------------|------|---|
| Cover plate (left) | 1 | |
| Cover plate (right) | 1 | |
| Tapping screw (ø4 × 10) | 2 | |
| Installation template | 1 | For positioning the indoor unit For under ceiling type |
| Bracket (left) | 1 | For suspending the indoor unit from ceiling |
| Bracket (right) | 1 | |
| Anchor bolt (M12) | 4 | |
| Spring washer | 4 | |
| Special nut | 4 | |
| Wall bracket | 2 | For suspending the indoor unit on the wall. |
| Tapping screw (ø4 × 20) | 6 | For fixing the wall bracket. |
| Coupler heat insulator (large) | 1 | For indoor side pipe joint (Large pipe) |
| Coupler heat insulator (small) | 1 | For indoor side pipe joint (Small pipe) |
| Nylon fastener | 1 | For fixing the drain hose |

| Name and Shape | Q'ty | Application |
|----------------------------|------|---|
| Drain hose | 1 | |
| Insulation (drain hose) | 1 | Adhesive type 70 × 230 |
| VT wire | 1 | For fixing the drain hose L 280 mm |
| Remote control unit | 1 | Use for air conditioner operation |
| Battery (penlight) | 2 | For remote control unit |
| Remote control unit holder | 1 | Use as remote control unit holder |
| Tapping screw (ø3 × 12) | 2 | For remote control unit holder installation |

OUTDOOR UNIT ACCESSORIES

| Name and Shape | Q'ty | Application |
|----------------|------|---|
| Drain pipe | 1 | For outdoor unit drain piping work (Heat & Cool model (Reverse cycle) only) |
| Drain cap | 1 | |

OPTIONAL PARTS FOR INDOOR UNIT

| Name and Shape | Part No. | Application |
|----------------|------------|----------------------------|
| Joint pipe-A | 9302812021 | For indoor side pipe joint |

2. OUTDOOR UNIT

- WARNING**
- (1) Install the unit where it will not be tilted by more than 5°.
- (2) When installing the outdoor unit where it may be exposed to strong wind, fasten it securely.
- (1) If possible, do not install the unit where it will be exposed to direct sunlight. (If necessary, install a blind that does not interfere with the air flow.)
- (2) Install the outdoor unit in a place where it will be free from being dirty or getting wet by rain as much as possible.
- (3) Install the unit when connection to the indoor unit is easy.
- (4) During heating operation, drain water flows from the outdoor unit. Therefore, install the outdoor unit in a place where the drain water flow will not be obstructed. (Reverse cycle model only)
- (5) Do not place animals and plants in the path of the warm air.
- (6) Take the air conditioner weight into account and select a place where noise and vibration are small.
- (7) Select a place so that the warm air and noise from the air conditioner do not disturb neighbors.
- (8) Provide the space shown in Fig. 2 so that the air flow is not blocked. Also for efficient operation, leave open three of the four directions front, rear, and both sides.

Fig. 2

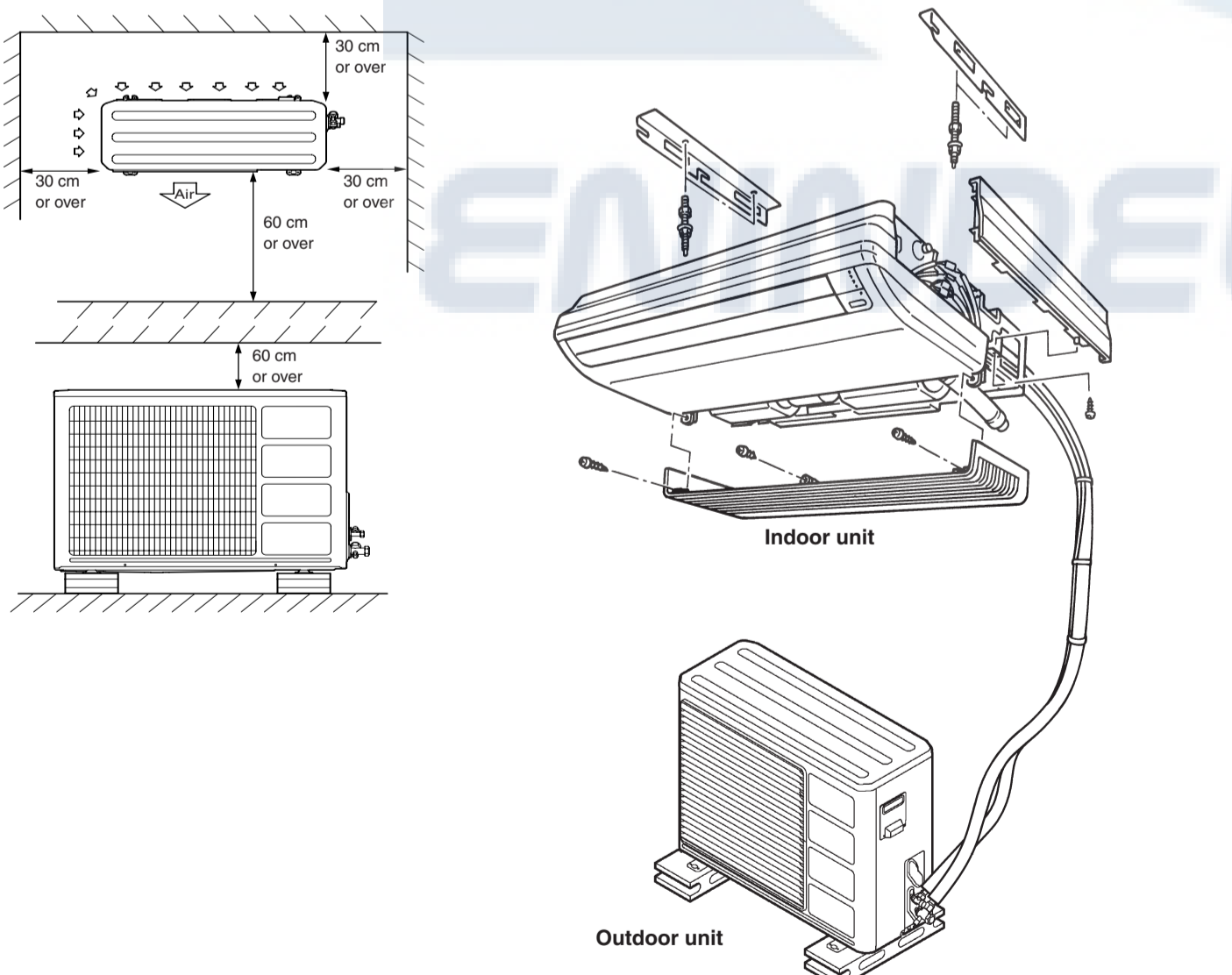

CONNECTION PIPE REQUIREMENT

| MODEL | 18,000 BTU class | | 24,000 BTU class | |
|--|-------------------|-------------------|-------------------|-------------------|
| | Small | La | Small | La |
| Diameter | 6.35 mm (1/4 in.) | 9.52 mm (3/8 in.) | 6.35 mm (1/4 in.) | 9.52 mm (3/8 in.) |
| Length | 20 m (66 ft) | 20 m (66 ft) | 20 m (66 ft) | 20 m (66 ft) |
| Maximum height difference between indoor and outdoor | 8 m (26 ft) | 8 m (26 ft) | 8 m (26 ft) | 8 m (26 ft) |

INSTALLATION PROCEDURE

Install the room air conditioner as follows:

1. PREPARING INDOOR UNIT INSTALLATION

1. REMOVE THE INTAKE GRILLE

Open the intake grille and remove the three screws (Fig. 3).

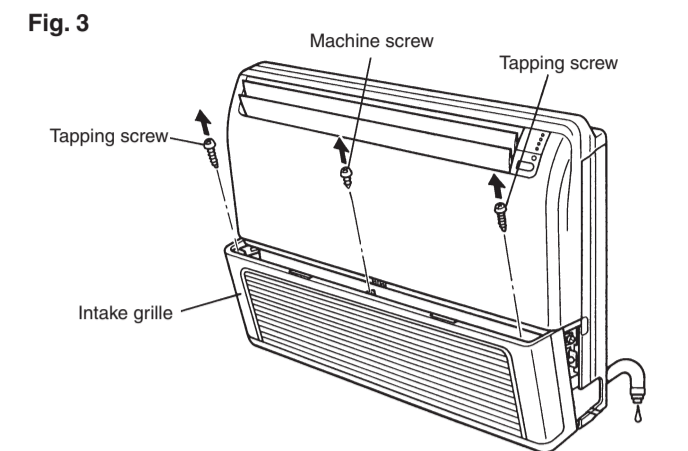

Remark: The main unit can be wired before the indoor unit is installed. Select the most appropriate installation order.

2. INDOOR UNIT INSTALLATION

A. FLOOR CONSOLE TYPE

1. DRILLING FOR PIPING

Select piping and drain directions (Fig. 4). The piping and drain can be made in three directions as shown below.

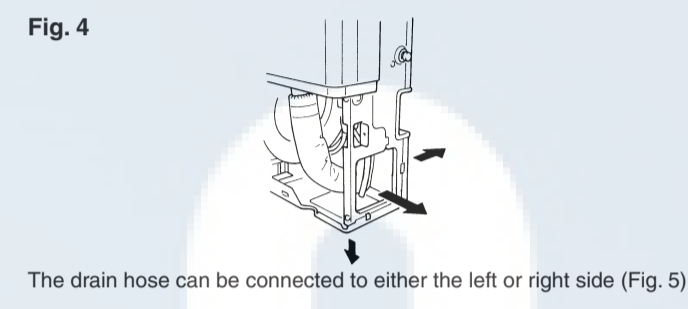

The drain hose can be connected to either the left or right side (Fig. 5).

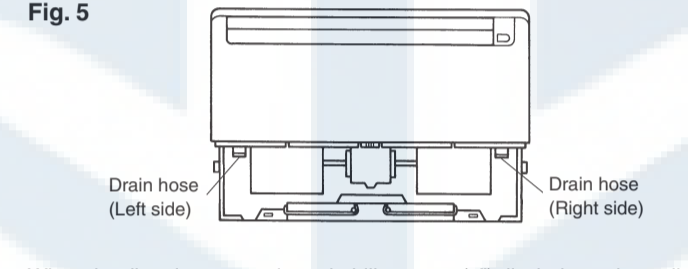

When the directions are selected, drill a 10 cm (4 in.) dia. hole on the wall so that the hole is tilted downward toward the outdoor for smooth water flow. When the pipe is led out from the rear, make a hole in Fig. 6, at the position shown.

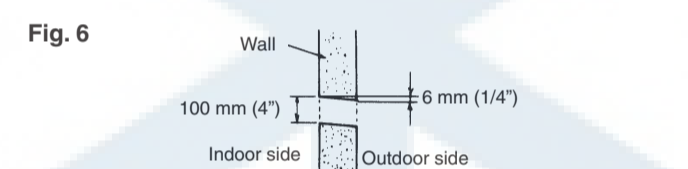

3. OUTDOOR UNIT INSTALLATION

1. OUTDOOR UNIT PROCESSING

- WARNING**
- (1) Install the unit where it will not be tilted by more than 5°.
- (2) When installing the outdoor unit where it may be exposed to strong wind, fasten it securely.
- Set the unit on a strong stand, such as one made of concrete blocks to minimize shock and vibration.
- Do not set the unit directly on the ground because it will cause trouble.
- Since the drain water flows out of the outdoor unit during heating operation, install the drain pipe and connect it to an commercial 16 mm hose. (Heat & Cool model (Reverse cycle) only)
- When installing the drain pipe, plug all the holes (* hole at one place) other than the drain pipe mounting hole in the bottom of the outdoor unit with putty so there is no water leakage. (Fig. 22) (Heat & Cool model (Reverse cycle) only)

CAUTION
Installation in cold regions. Do not use the accessory drain pipe and drain cap. (If the drain pipe and drain cap are used, the drain water in the pipe may freeze in extremely cold weather.)

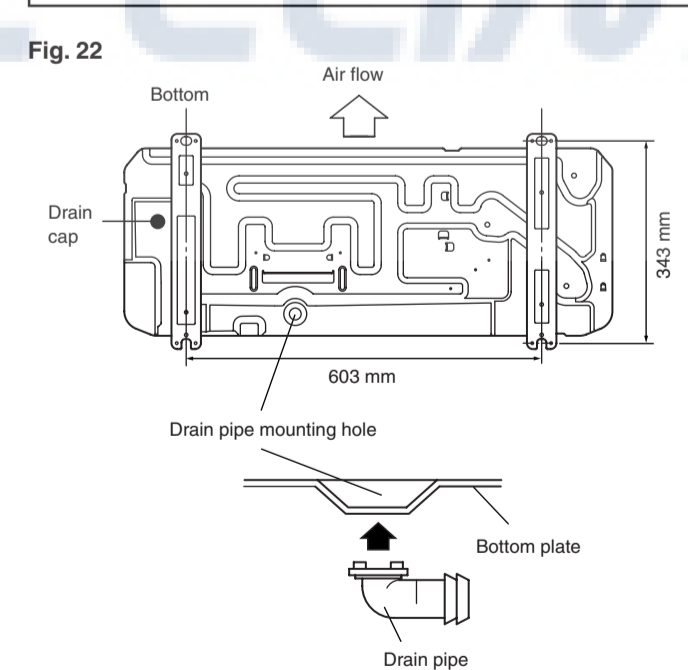

2. OUTDOOR UNIT CONNECTION CORD AND PIPE CONNECTION PREPARATIONS

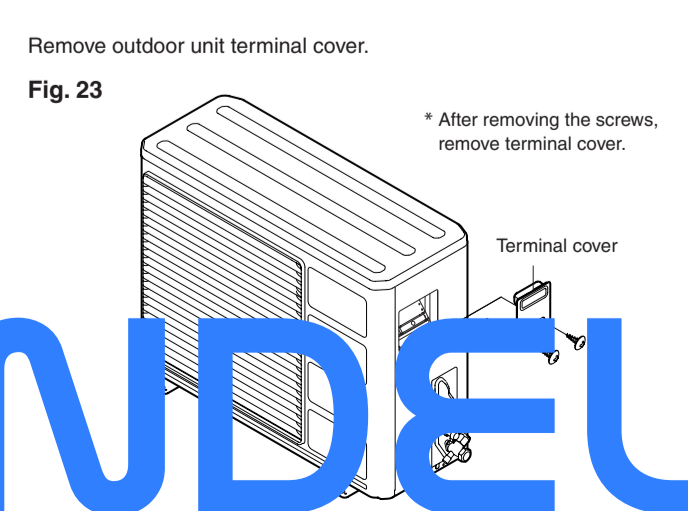

4. CONNECTING THE PIPING

When installing set to wall install the accessory wall bracket at the position shown in Fig. 7, and mount the set to it.

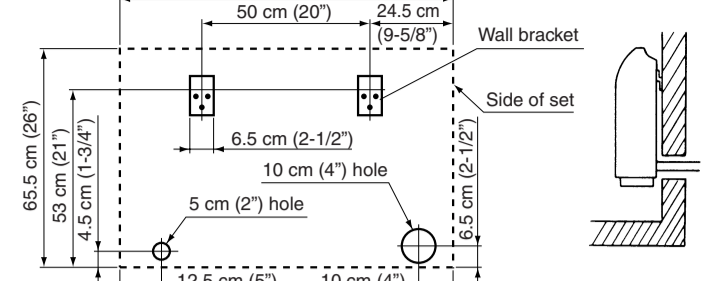

2. INSTALLING THE DRAIN HOSE

Select whether the drain hose will be connected to the left or right side (Fig. 8). Insert the drain hose into the drain pan, then secure the drain hose with a nylon fastener (Fig. 8).

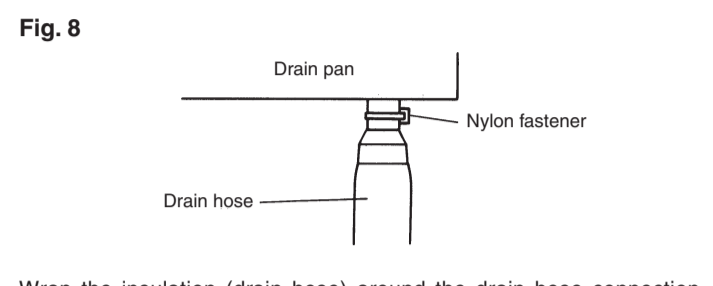

Wrap the insulation (drain hose) around the drain hose connection (Fig. 9).

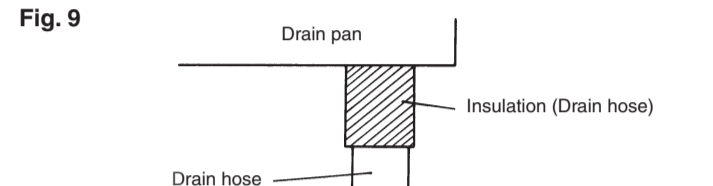

Be sure to arrange the drain hose so that it is leveled lower than the drain hose connecting port of the indoor unit.

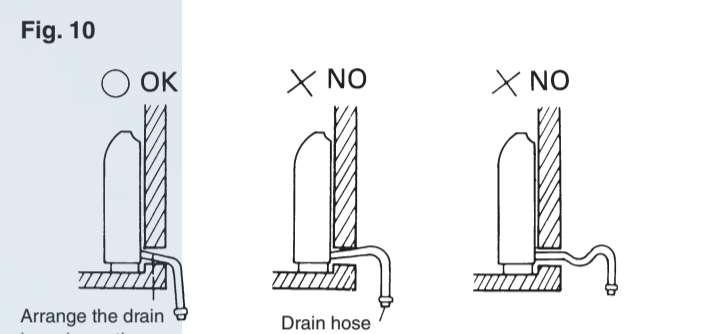

CAUTION
Do not install the unit so that the drain hose side is too high. Height A should be less than 5 mm (Fig. 11).

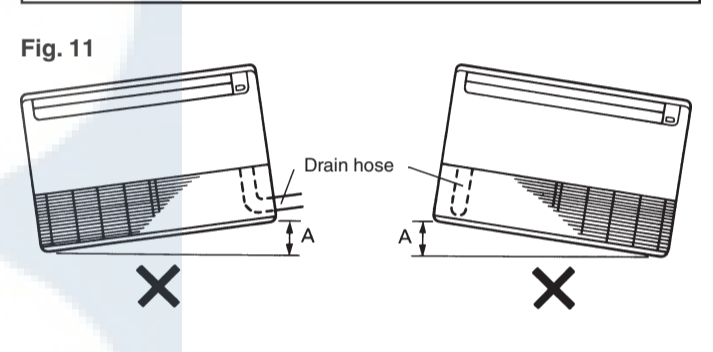

4. CONNECTING THE PIPING

- WARNING**
- Do not use the existing (for R22) piping and flare nuts.
 - If existing materials are used, the pressure inside the refrigerant cycle will rise and cause breakage, injury, etc. (Use the special R410A materials.)
- CAUTION**
- (1) Do not use mineral oil on flared part. Prevent mineral oil from getting into the system as this would reduce the lifetime of the units.
- (2) Never use piping which has been used for previous installations. Only use parts which are delivered with the unit.
- (3) While welding the pipes, be sure to blow dry nitrogen gas through them.

CAUTION
The maximum lengths of this product are shown in table 3. If the units are further apart than this, correct operation cannot be guaranteed.

1. LIMITATION OF REFRIGERANT PIPING LENGTH

| | Table 3 |
|---------------------------|--------------|
| Max length (L) | 20 m (66 ft) |
| Max height difference (H) | 8 m (20 ft) |

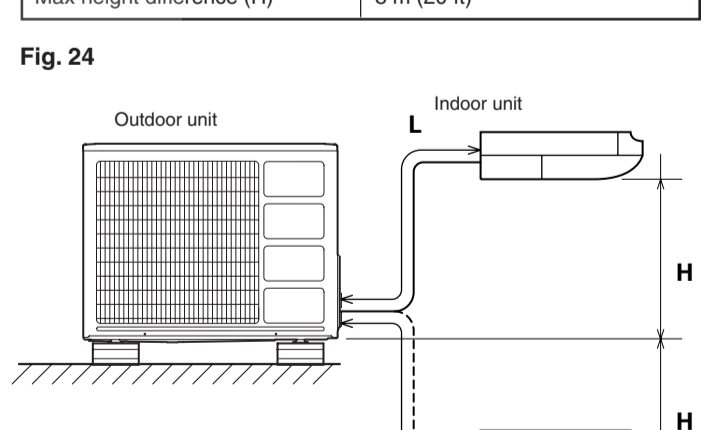

CAUTION
Be sure to apply the pipe against the port on the indoor unit correctly. If the centering is improper, the flare nut cannot be tightened smoothly. If the flare nut is forced to turn, the threads will be damaged.

B. UNDER CEILING TYPE

Using the installation template, drill holes for piping and anchor bolts (for holes) (Fig. 12).

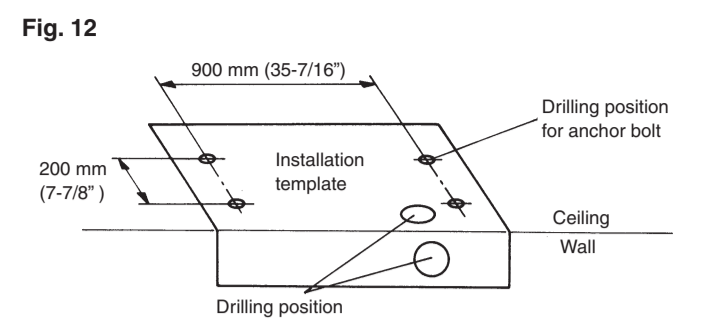

1. DRILLING FOR PIPING

Select piping and drain directions (Fig. 13).

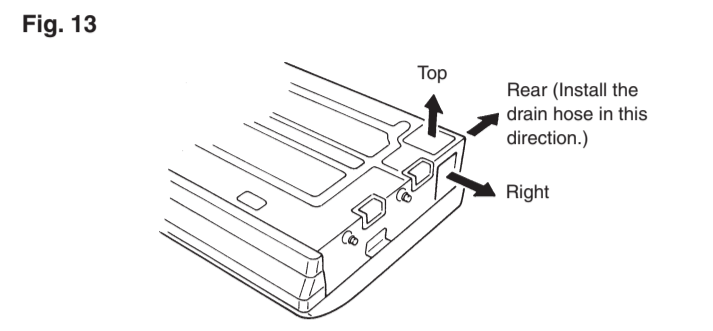

CAUTION
Install the drain hose at the rear; it should not be installed on the top or right side.

When the directions are selected, drill 80 mm (3-1/8") and 50 mm (2") or 150 mm (6") dia. hole on the wall so that the hole is tilted downward toward the outdoor for smooth water flow.

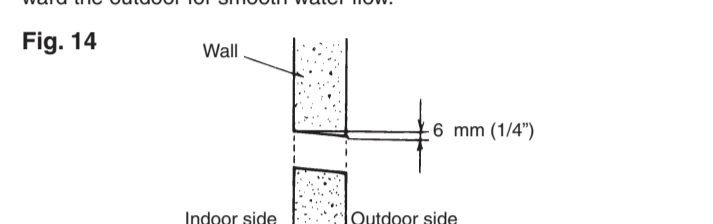

2. DRILLING HOLES FOR ANCHOR BOLTS AND INSTALLING THE ANCHOR BOLTS

With a concrete drill, drill four 12.7 mm (1/2") dia. holes (Fig. 15).

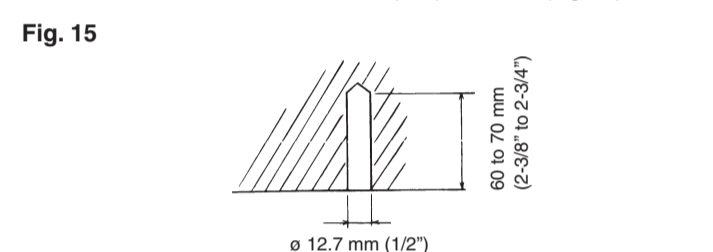

Insert the anchor bolts into the drilled holes, and drive the pins completely into the anchor bolts with a hammer (Fig. 16).

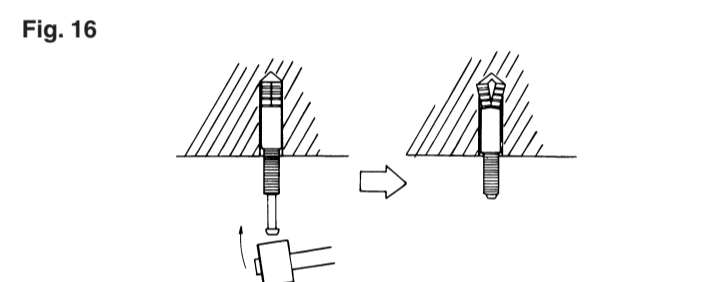

3. INSTALLING BRACKETS

Install the brackets with nuts, washers and spring washers (Fig. 17).

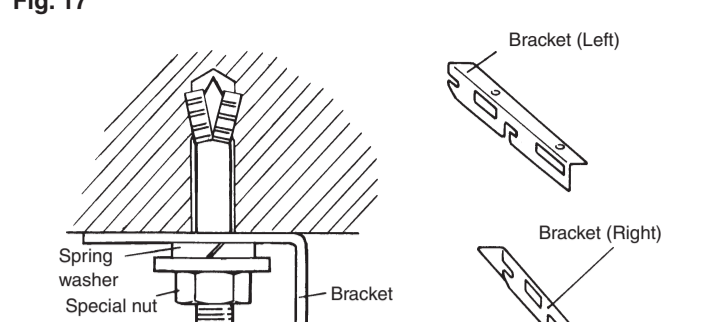

4. INSTALLING INDOOR UNIT

Reset the hex bolts as shown in Fig. 18.

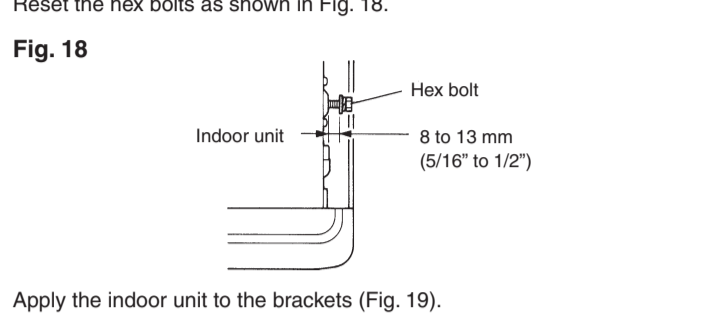

Apply the indoor unit to the brackets (Fig. 19).

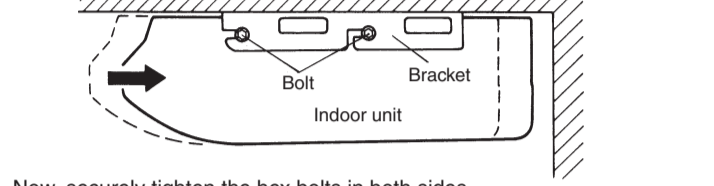

5. INSTALLING THE DRAIN HOSE

Select whether the drain hose will be connected to the left or right side (Fig. 5). Insert the drain hose into the drain pan, then secure the drain hose with a nylon fastener (Fig. 8). Wrap the insulation (drain hose) around the drain hose connection (Fig. 9). Be sure to arrange the drain hose so that it is leveled lower than the drain hose connecting port of the indoor unit (Fig. 20).

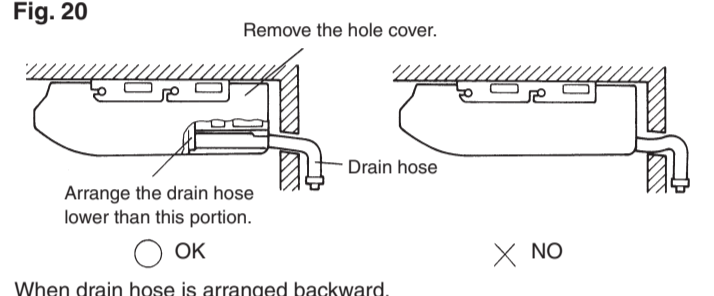

When drain hose is arranged backward. Secure the drain hose with the VT wire (Fig. 21).

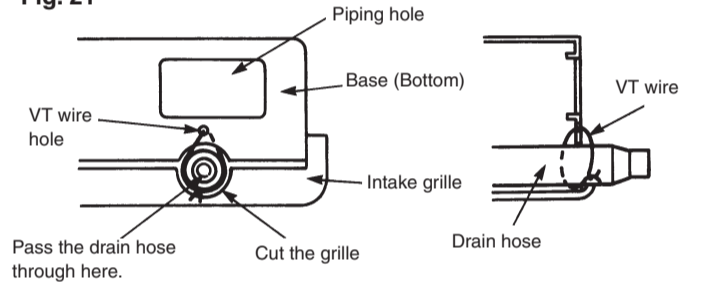

2. FLARING PROCESSING

- Cut the connection pipe to the necessary length with a pipe cutter.
- Hold the pipe downward so that cuttings will not enter the pipe and remove the burrs.
- Insert the flare nut (always use the flare nut attached to the indoor and outdoor units respectively) onto the pipe and perform the flare processing with a flare tool. Use the special R410A flare tool, or the conventional (for R22) flare tool. When using the conventional flare tool, always use an allowance adjustment gauge and secure the A dimension shown in table 4.
- Install the outdoor unit wall cap (supplied with the optional installation set or procured at the site) to the wall hole piping.
- Connect the outdoor unit and indoor unit piping.
- After matching the center of the flare surface and tightening the nut hand tight, tighten the nut to the specified tightening torque with a torque wrench.

| Pipe outside diameter | A (mm) | | |
|-----------------------|-----------------------------------|---|---------------|
| | Flare tool for R410A, clutch type | Conventional (R22) flare tool Clutch type | Wing nut type |
| 6.35 mm (1/4 in.) | 0 to 0.5 | 1.0 to 1.5 | 1.5 to 2.0 |
| 9.52 mm (3/8 in.) | 0 to 0.5 | 1.0 to 1.5 | 1.5 to 2.0 |
| 15.88 mm (5/8 in.) | 0 to 0.5 | 1.0 to 1.5 | 2.0 to 2.5 |

3. BENDING PIPES

- When bending the pipe, be careful not to crush it.
- To prevent crushing of the pipe, do not bend the pipe at a radius curvature of 100 mm or over.
- If the copper pipe is bent the pipe or pulled to often, it will become stiff. Do not bend the pipes more than three times at one place.

4. CONNECTION PIPES

(1) Centering the pipe against port on the indoor unit, turn the flare nut with your hand (Fig. 26). Be sure that the small pipe is completely installed before connecting the large pipe.

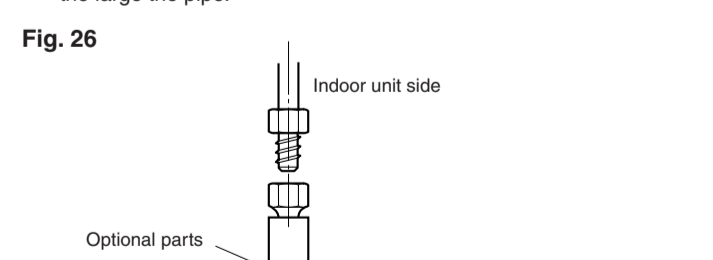

CAUTION
Be sure to apply the pipe against the port on the indoor unit correctly. If the centering is improper, the flare nut cannot be tightened smoothly. If the flare nut is forced to turn, the threads will be damaged.

5. HEAT INSULATION ON THE PIPE JOINTS (INDOOR SIDE ONLY)

Put coupler heat insulator on the joints (indoor side only) (Fig. 28).

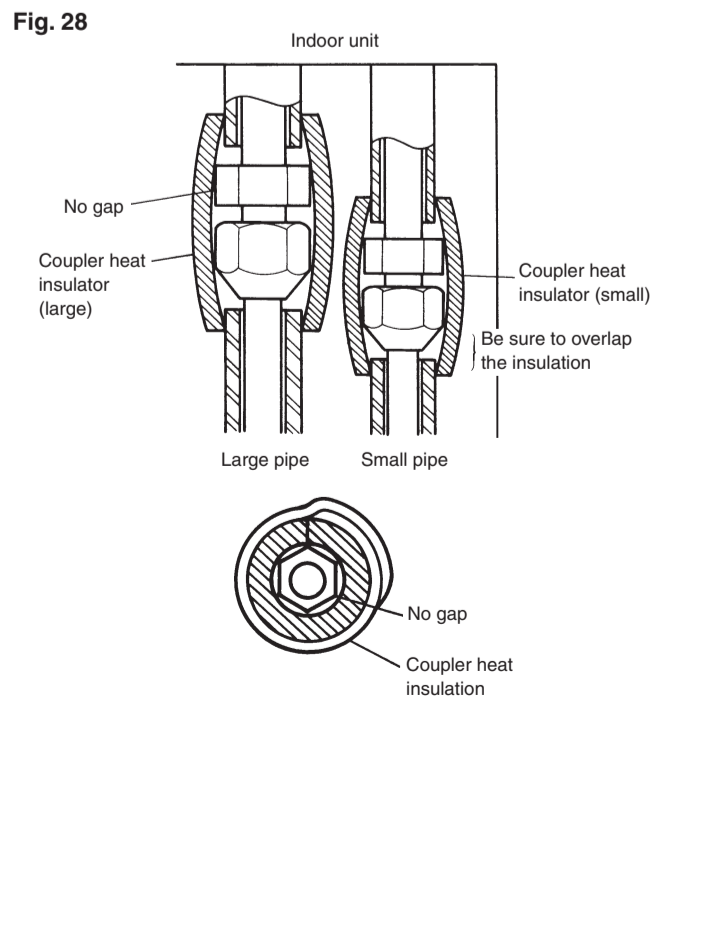

5 VACUUMING AND ADDITIONAL CHARGE

CAUTION

- (1) Do not purge the air with refrigerants but use a vacuum pump to vacuum the installation! There is no extra refrigerant in the outdoor unit for air purging!
- (2) Use a vacuum pump for R410A exclusively. Using the same vacuum pump for different refrigerants may damage the vacuum pump or the unit.

1. VACUUM

- Remove the cap, and connect the gauge manifold and the vacuum pump to the charging valve by the service hoses.
- Vacuum the indoor unit and the connecting pipes until the pressure gauge indicates -0.1 MPa (-76 cmHg).
- When -0.1 MPa (-76 cmHg) is reached, operate the vacuum pump for at least 15 minutes.
- Disconnect the service hoses and fit the cap to the charging valve to the specified torque.
- Remove the blank caps, and fully open the spindles of the 2-way and 3-way valves with a hexagon wrench (Torque: 6 to 7 N·m (60 to 70 kgf·cm)).
- Tighten the blank caps of the 2-way valve and 3-way valve to the specified torque.

Table 6

| Blank cap (2-way valve) | Tightening torque |
|-------------------------|----------------------------------|
| Blank cap (2-way valve) | 20 to 25 N·m (200 to 250 kgf·cm) |
| Blank cap (3-way valve) | 30 to 35 N·m (300 to 350 kgf·cm) |
| Charging port cap | 10 to 12 N·m (100 to 120 kgf·cm) |

Fig. 29

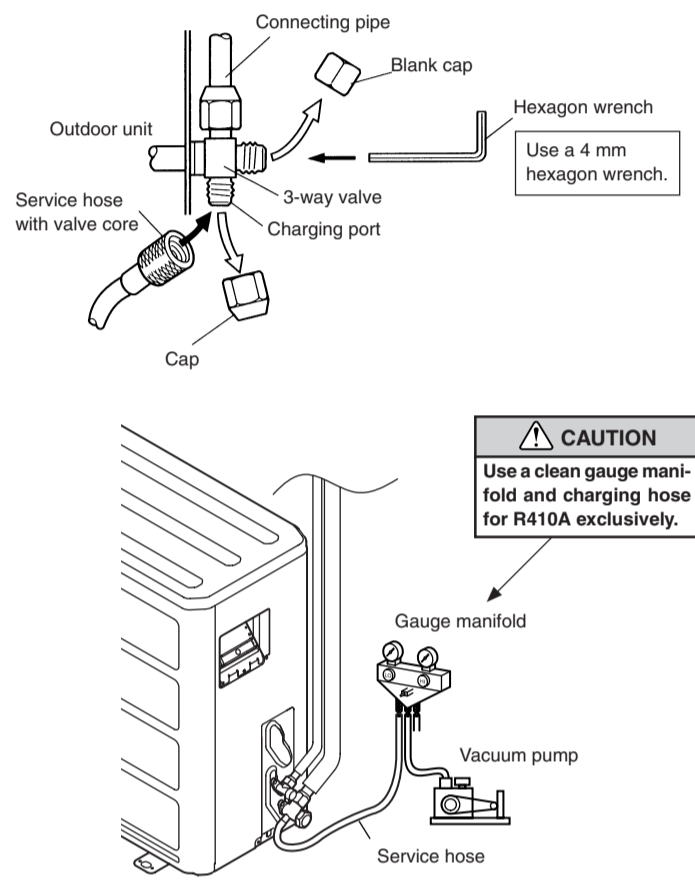

2. ADDITIONAL CHARGE

Refrigerant suitable for a piping length of 7.5 m is charged in the outdoor unit at the factory. When the piping is longer than 7.5 m, additional charging is necessary. For the additional amount, see the table below.

Table 7

| Additional refrigerant | Pipe length (25 ft) | Pipe length | | | | g/m (oz/ft) |
|---------------------------------------|---------------------------------------|---------------|----------------|-----------------|-----------------|----------------|
| | | 75 m (25 ft) | 10 m (33 ft) | 15 m (49 ft) | 20 m (66 ft) | |
| 18,000 BTU/h class 24,000 BTU/h class | None | 50 g (1.8 oz) | 150 g (5.3 oz) | 250 g (8.9 oz) | 20 g (0.71 oz) | |
| Heat & Cool model (Reverse cycle) | 18,000 BTU/h class 24,000 BTU/h class | None | 50 g (1.8 oz) | 150 g (5.3 oz) | 250 g (8.9 oz) | 20 g (0.71 oz) |
| Heat & Cool model (Reverse cycle) | 24,000 BTU/h class | None | 100 g (3.5 oz) | 300 g (10.6 oz) | 500 g (17.7 oz) | 40 g (1.41 oz) |

CAUTION

- When moving and installing the air conditioner, do not mix gas other than the specified refrigerant (R410A) inside the refrigerant cycle.
- When charging the refrigerant R410A, always use an electronic balance for refrigerant charging (to measure the refrigerant by weight).
- When charging the refrigerant, take into account the slight change in the composition of the gas and liquid phases, and always charge from the liquid phase side whose composition is stable.
- Add refrigerant from the charging valve after the completion of the work.
- If the units are further apart than the maximum pipe length, correct operation can not be guaranteed.

7 HOW TO CONNECT WIRING TO THE TERMINALS

A. For solid core wiring (or F-cable)

- Cut the wire end with a wire cutter or wire-cutting pliers, then strip the insulation to about 25 mm (1 5/16") of expose the solid wire.
- Using a screwdriver, remove the terminal screw(s) on the terminal board.
- Using pliers, bend the solid wire to form a loop suitable for the terminal screw.
- Shape the loop wire properly, place it on the terminal board and tighten securely with the terminal screw using a screwdriver.

B. For strand wiring

- Cut the wire end with a wire cutter or wire-cutting pliers, then strip the insulation to about 10 mm (3/8") of expose the strand wiring.
- Using a screwdriver, remove the terminal screw(s) on the terminal board.
- Using a round terminal fastener or pliers, securely clamp a round terminal to each stripped wire end.
- Position the round terminal wire, and replace and tighten the terminal screw using a screwdriver.

Fig. 30

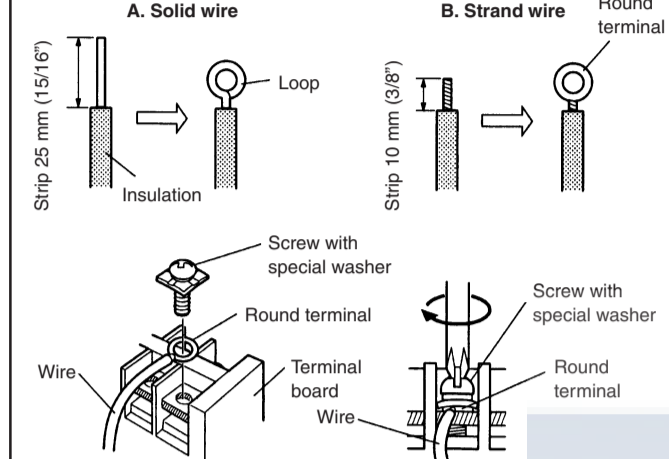

HOW TO FIX CONNECTION CORD AND POWER CABLE AT THE CORD CLAMP

After passing the connection cord and power cable through the insulation tube, fasten it with the cord clamp.

Fig. 31

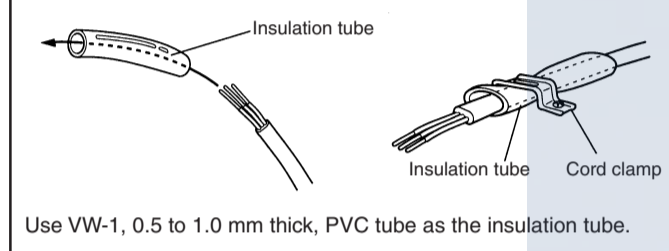

8 ELECTRICAL REQUIREMENT

- Electric wire size and fuse capacity:

Table 8

| MODEL | 18,000 BTU class | | 24,000 BTU class | |
|-------------------------|------------------|------|------------------|------|
| | MAX. | MIN. | MAX. | MIN. |
| Power supply cord (mm²) | 3.5 | 2.5 | 3.5 | 2.5 |
| Connection cord (mm²) | 2.5 | 1.5 | 2.5 | 1.5 |
| Fuse capacity (A) | 20 | | 30 | |

- Always make the air conditioner power supply a special branch circuit and provide a special breaker.
- Always use H07RN-F or equivalent as the power supply cord and the connection cord.

9 ELECTRICAL WIRING

CAUTION

- Match the terminal block numbers and connection cord colors with those of the outdoor unit. Erroneous wiring may cause burning of the electric parts.
- Connect the connection cords firmly to the terminal block. Imperfect installation may cause a fire.
- Always fasten the outside covering of the connection cord with the cord clamp. (If the insulator is chafed, electric leakage may occur.)
- Always connect the ground wire.

1. INDOOR UNIT SIDE

- Remove the electric component box.

Fig. 32

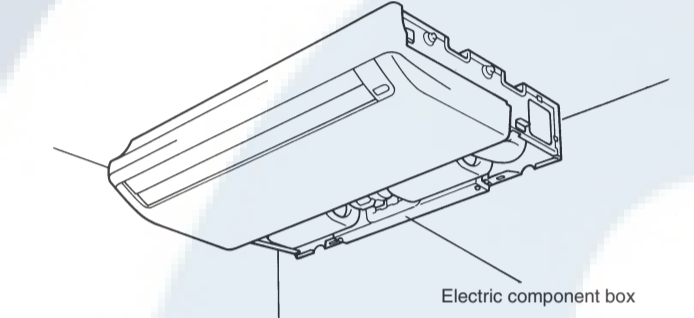
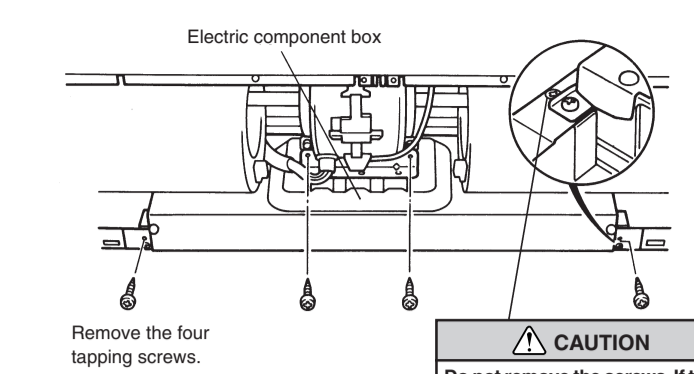
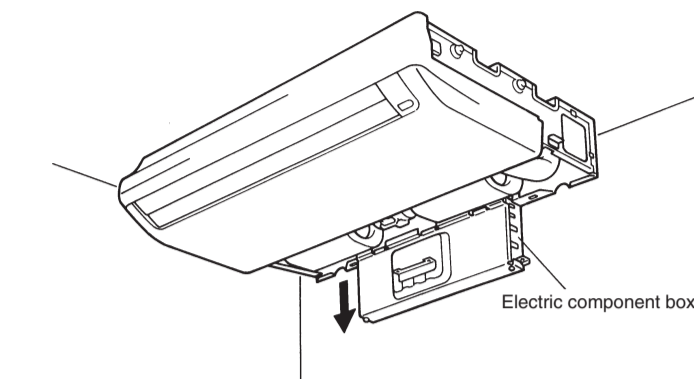

Fig. 33



- Pull out the electric component box.

Fig. 34



- Remove the electric component box cover.

Fig. 35

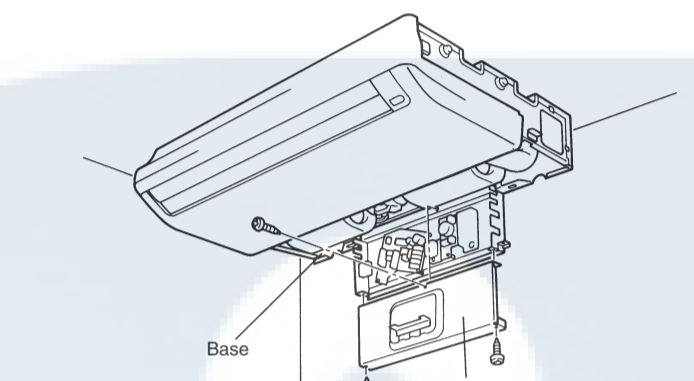

- Remove the three tapping screws.

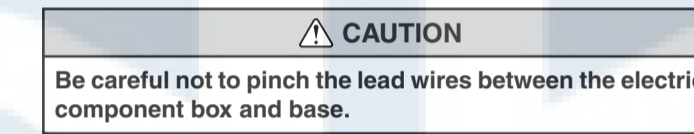

CAUTION

Be careful not to pinch the lead wires between the electric component box and base.

(4) Wiring

Heat & Cool model (Reverse cycle)

- Remove the cord clamp.
- Process the end of the connection cords to the dimensions shown in Fig. 36.
- Connect the end of the connection cord fully into the terminal block.

Fig. 36

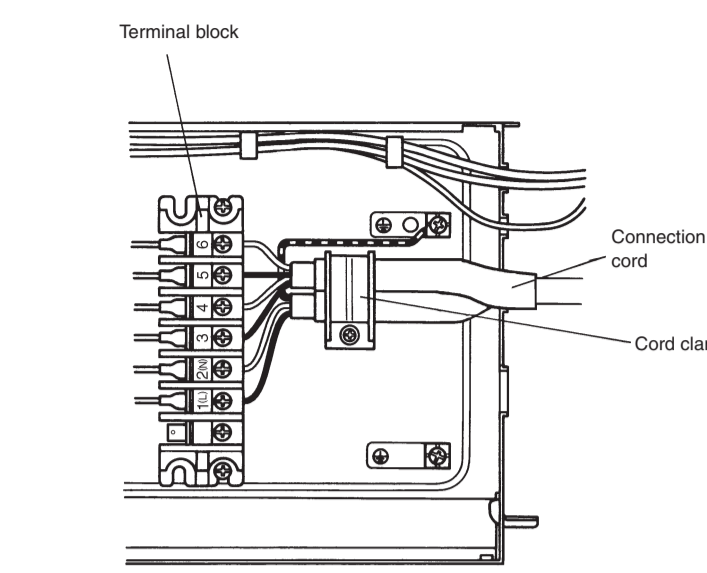

- Fasten the connection cord with a cord clamp.
- Fasten the end of the connection cord with the screw.

(Cooling model)

- Remove the cord clamp.
- Process the end of the connection cords to the dimensions shown in Fig. 37.
- Connect the end of the connection cord fully into the terminal block.

Fig. 37

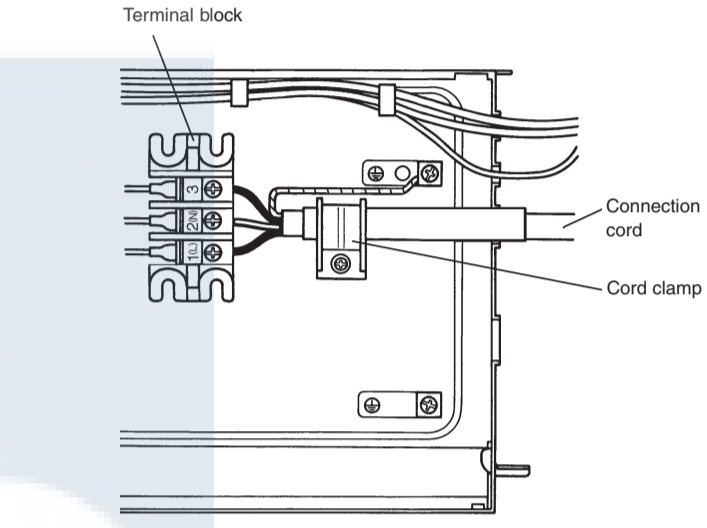

- Fasten the connection cord with a cord clamp.
- Fasten the end of the connection cord with the screw.

(5) Floor console/Under ceiling select switch

- The electrical circuits for this were set for use as a ceiling type at the factory. The following changes must be made to the settings if the unit is to be used as a floor type.
- Changing the settings for the electrical circuits. Switch 1 (SW1) on the printed circuit board inside the electric component box must be set as follows.

Fig. 38

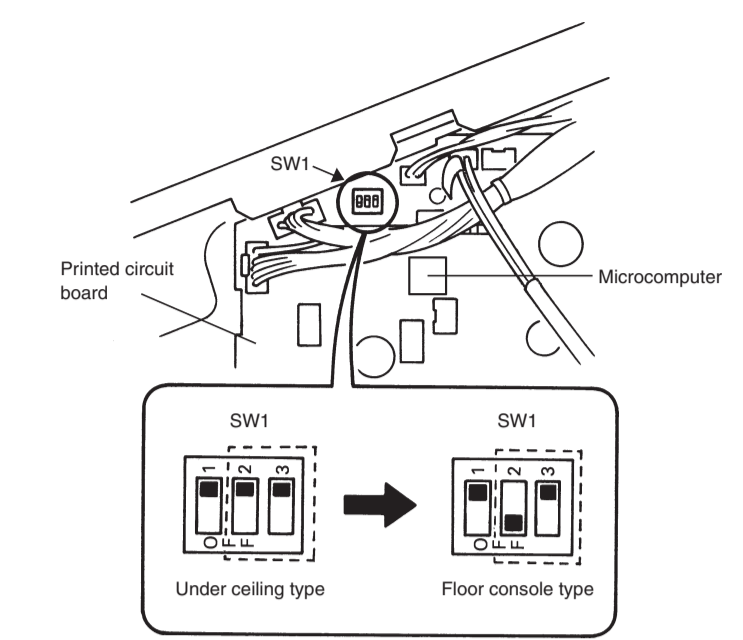

2. OUTDOOR UNIT SIDE

Fig. 39

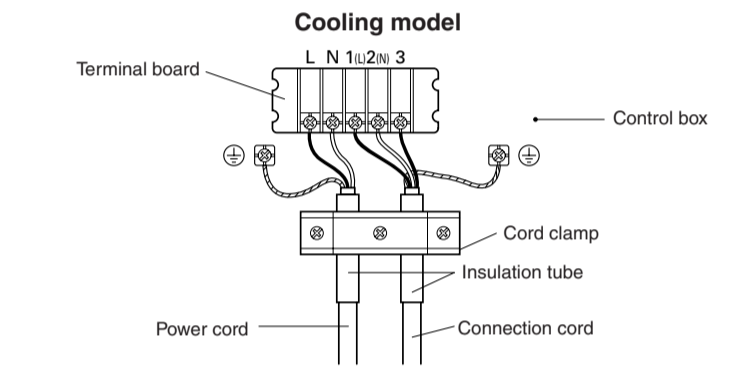
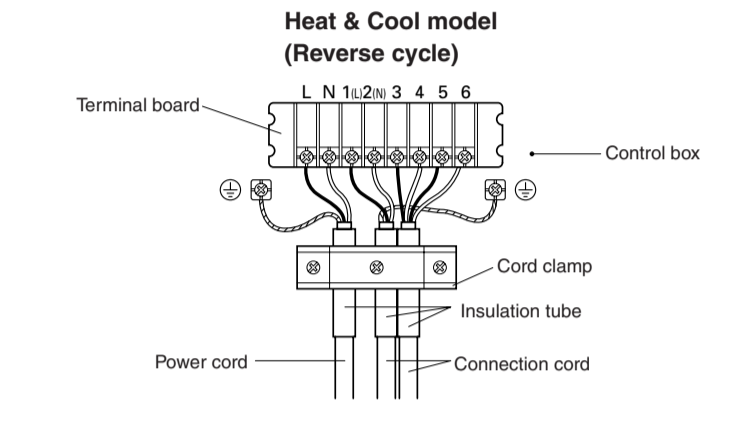
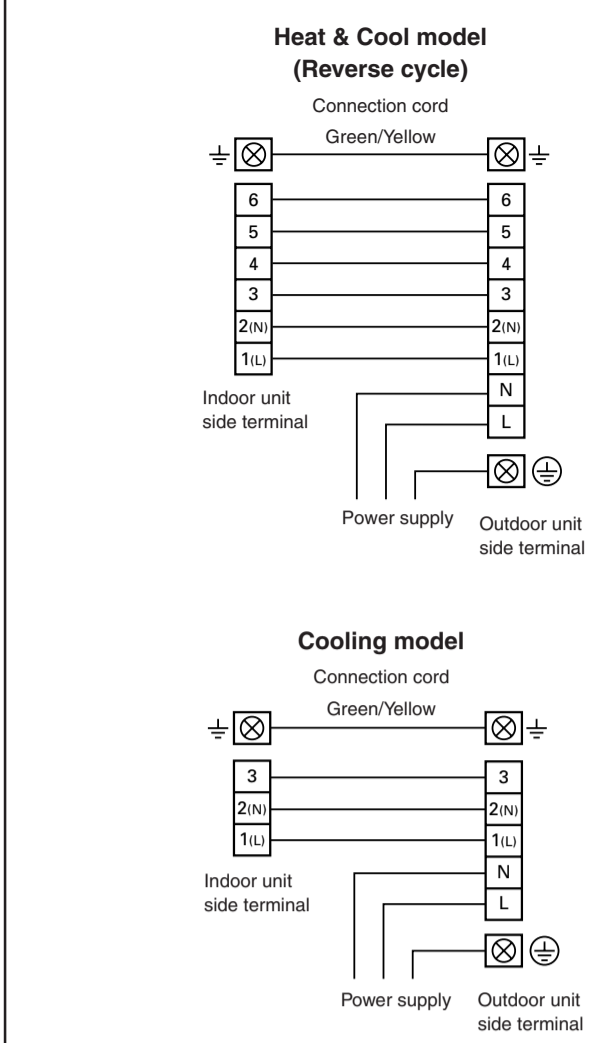
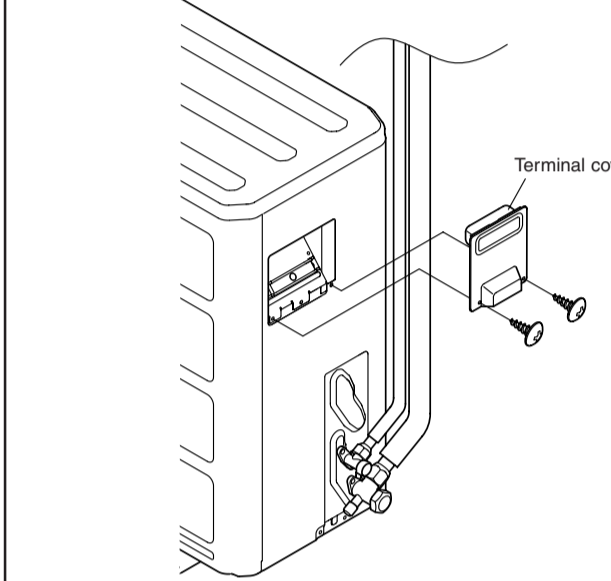

Fig. 40



3. INSTALL THE TERMINAL COVER

Fig. 41



10 POWER

WARNING

- The rated voltage of this product is 230V A.C. 50Hz.
- Before turning on the verify that the voltage is within the 198V to 264V range.
- Always use a special branch circuit and install a special receptacle to supply power to the room air conditioner.
- Use a circuit breaker and receptacle matched to the capacity of the room air conditioner.
- The circuit breaker is installed in the permanent wiring. Always use a circuit that can trip all the poles of the wiring and has an isolation distance of at least 3 mm between the contacts of each pole.
- Perform wiring work in accordance with standards so that the room air conditioner can be operated safely and positively.
- Install a leakage circuit breaker in accordance with the related laws and regulations and electric company standards.

CAUTION

- The power source capacity must be the sum of the room air conditioner current and the current of other electrical appliances. When the current contracted capacity is insufficient, change the contracted capacity.
- When the voltage is low and the air conditioner is difficult to start, contact the power company the voltage raised.

11 TEST RUNNING

- Perform test operation and check items 1 and 2 below.
- For the operation method, refer to the operating manual.
- The outdoor unit may not run, depending on the room temperature. In this case, the TEST RUN signal is received during air conditioner operation (use a metallic object to short the two metal contacts under the battery compartment lid and send the TEST RUN signal from the remote control unit).

Fig. 42

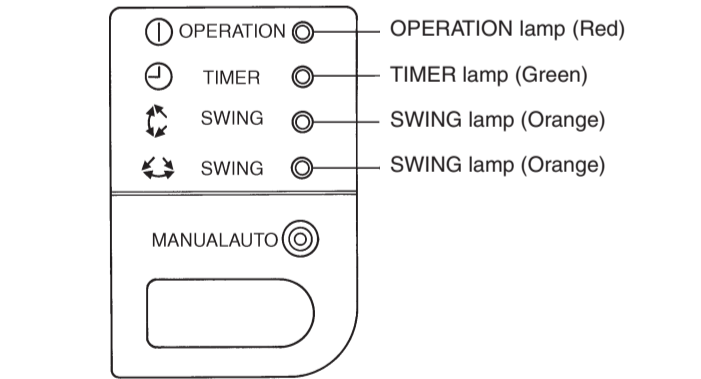
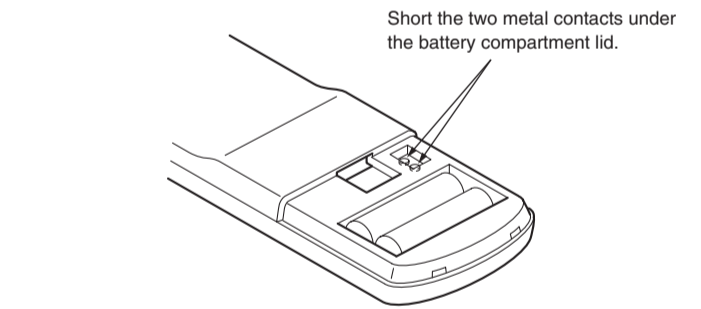

Operation can be checked by lighting and flashing of the display section OPERATION and TIMER lamps.

- Test running: When the air conditioner is run by pressing the remote control unit test run button, the OPERATION and TIMER lamps flash slowly at the same time.

- Error: The OPERATION, TIMER and SWING lamps operate as follows (Table 9) according to the error contents.

Table 9

| Error contents | Error display | | |
|---|-----------------|---------------|----------------|
| | OPERATION (RED) | TIMER (GREEN) | SWING (ORANGE) |
| Indoor unit circuit board error | ○ | ○ | — |
| Indoor unit room temperature sensor opened | 2 times ● | ○ | — |
| Indoor unit room temperature sensor short circuited | 2 times ● | ○ | — |
| Indoor unit piping sensor opened | 3 times ● | ○ | — |
| Indoor unit piping sensor short circuited | 3 times ● | ○ | — |
| Indoor unit fan error | 6 times ● | ○ | — |

○ : Fast flashing ● : Slow flashing — : Off

CHECK ITEMS

(1) INDOOR UNIT

- Is operation of each button on the remote control unit normal?
- Does each lamp light normally?
- Do not air flow direction louvers operate normally?
- Is the drain normal?
- Is there any abnormal noise and vibration during operation?

(2) OUTDOOR UNIT

- Is there any abnormal noise and vibration during operation?
- Will noise, wind, or drain water from the unit disturb the neighbors?
- Is there any gas leakage?
- Do not operate the air conditioner in the test running state for a long time.
- For the operation method, refer to the operating manual and perform operation check.

12 MOUNT THE COVER PLATE AND THE INTAKE GRILLE

1. MOUNT THE COVER PLATE (RIGHT)

- Cut a pipe exit hole in the right plate. This is only when the pipe exits from the right side. (This operation is not required when the provision is on the top or rear.)

Fig. 43

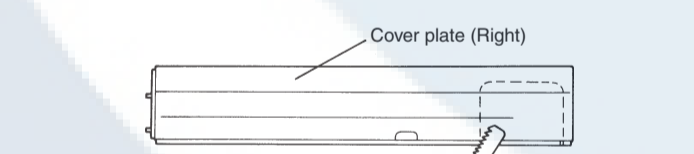

- Join the cover plates (right) and mount with screws (Fig. 44).

Fig. 44

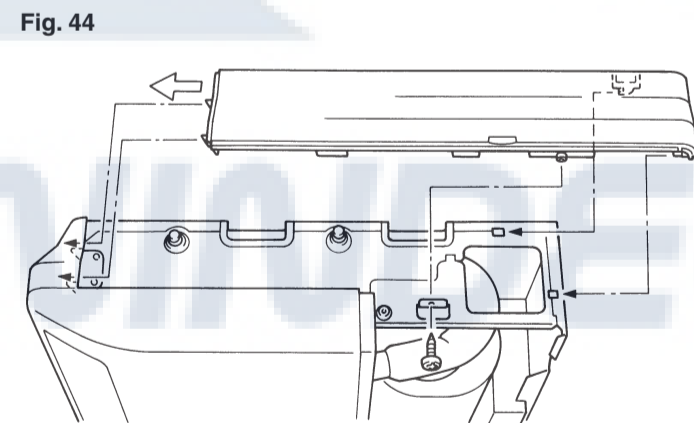

2. MOUNT THE COVER PLATE (LEFT)

- Join the cover plates (left) and mount with screws.

Fig. 45

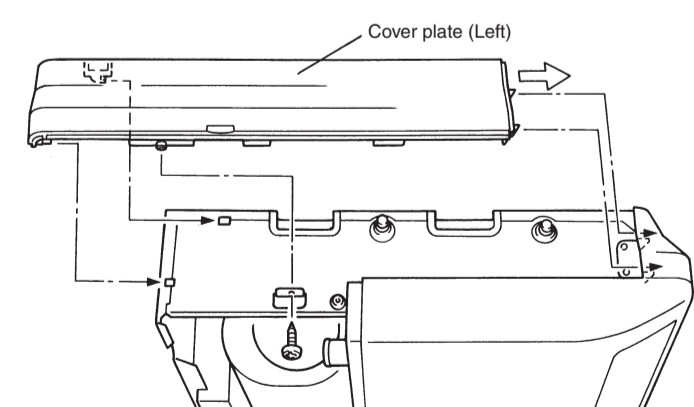

3. MOUNT THE INTAKE GRILLE

- Cut the right side of the intake grille. This is only when the pipe exits from the right side (Fig. 46).

Fig. 46

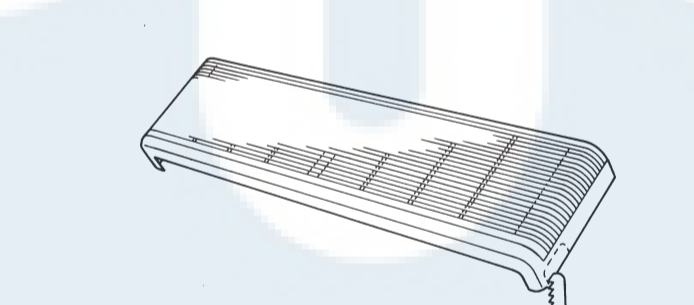

- Insert the hinges on the bottom of the intake grille into the holes in the base assembly. Then mount the arms to the three areas on the top of the intake grille (Fig. 47).

Fig. 47

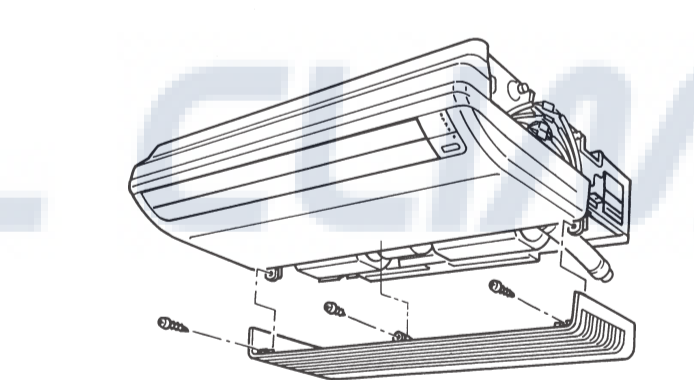

13 REMOTE CONTROL UNIT INSTALLATION

CAUTION

- Check that the indoor unit correctly receives the signal from the remote control unit, then install the remote control unit holder.
- Select the remote control unit holder selection site by paying careful attention to the following: Avoid places in direct sunlight. Select a place that will not be affected by the heat from a stove, etc.

1. REMOTE CONTROL UNIT HOLDER INSTALLATION

- Install the remote control unit with a distance of 7 m between the remote control unit and the photocell as the criteria. However, when installing the remote control unit, check that it operates positively.
- Install the remote control unit holder to a wall, pillar, etc. with the tapping screw (Fig. 48).

Fig. 48

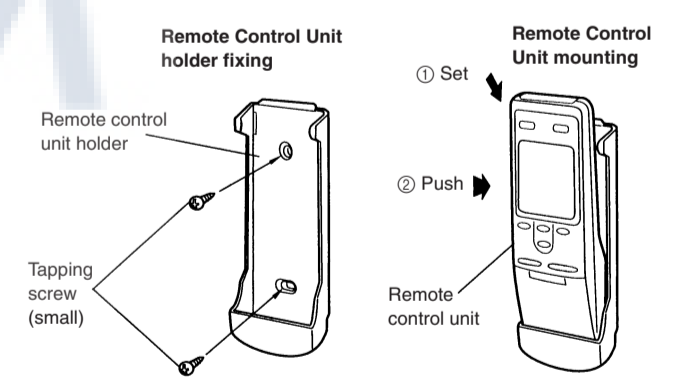

2. SWITCHING REMOTE CONTROL UNIT SIGNAL CODES

- Air conditioner settings

Fig. 49

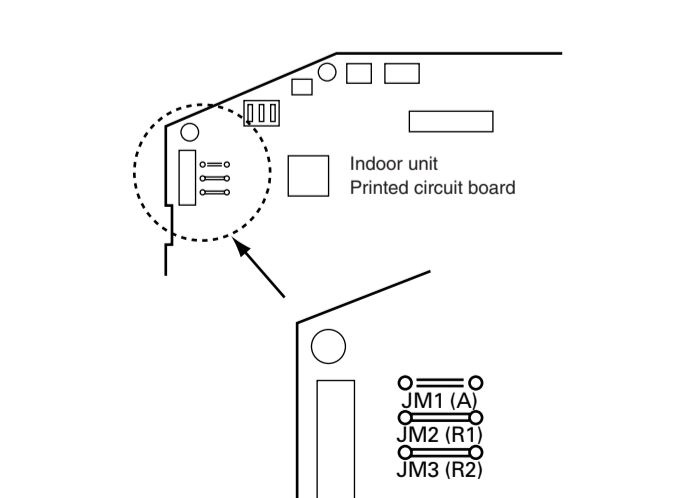

- Remote control unit settings
- Press the START/STOP button and display only the clock.

Fig. 50

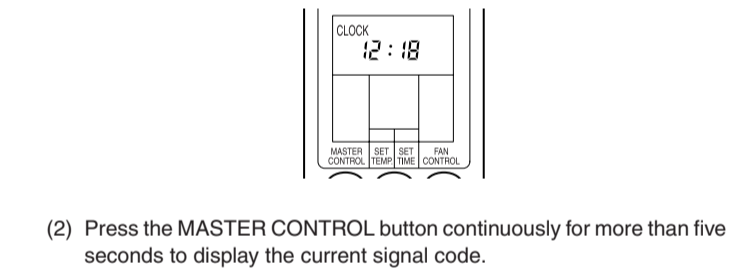
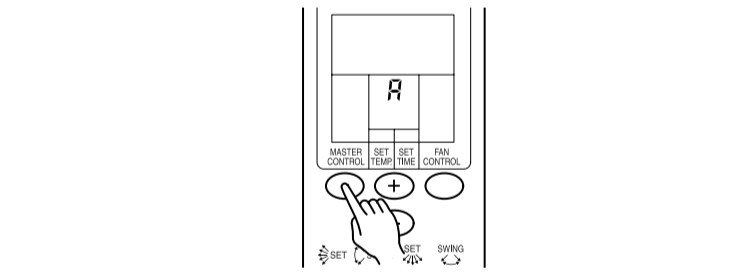
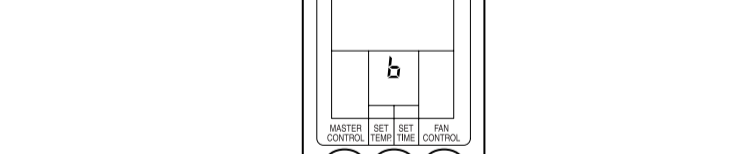

Fig. 51



- Change the signal code with the 1/2 button (A-b-c-d).

Fig. 52



- Confirm the setting of the remote control unit signal code and the printed circuit board setting. If these are not confirmed, the remote control unit cannot be used to operate for the air conditioner.

Table 10

| Jumper wire | | Remote control unit signal code |
|-------------|------------|---------------------------------|
| JM2 | JM3 | |
| Connect | Connect | A (Primary setting) |
| Connect | Disconnect | B |
| Disconnect | Connect | C |
| Disconnect | Disconnect | D |

14 CUSTOMER GUIDANCE

Explain the following to the customer in accordance with the operating manual:

- Starting and stopping method, operation switching, temperature adjustment, timer, air flow switching, and other remote control unit operations.
- Air filter removal and cleaning, and how to use the air louvers.
- Give the operating and installation manuals to the customer.
- If the signal code is changed, explain to the customer how it changed (the system returns to signal code A when the batteries in the remote control unit are replaced).