



SPLIT TYPE  
ROOM AIR CONDITIONER  
WALL MOUNTED TYPE

# SERVICE MANUAL



Indoor unit	Outdoor unit
ASHA07LGC	AOHR07LGC
ASHA09LGC	AOHR09LGC
ASHA12LGC	AOHR12LGC

## CONTENTS

SPECIFICATIONS.....	1
DIMENSIONS.....	3
REFRIGERANT SYSTEM DIAGRAM....	4
CIRCUIT DIAGRAM.....	5
INDOOR PCB CIRCUIT DIAGRAM.....	6
OUTDOOR PCB CIRCUIT DIAGRAM ...	9
ERROR CONTENTS.....	11
PARTS (Indoor unit).....	12
PARTS (Outdoor unit).....	16
ACCESSORIES.....	20

# SPECIFICATIONS

## ELECTRICAL DATA

TYPE		Cool & heat inverter		
INDOOR UNIT		ASHA07LGC	ASHA09LGC	ASHA12LGC
OUTDOOR UNIT		AOHR07LGC	AOHR09LGC	AOHR12LGC
COOLING CAPACITY		2.10 kW	2.50 kW	3.40 kW
HEATING CAPACITY		3.00 kW	3.20 kW	4.00 kW
POWER SOURCE		230 V	230 V	230 V
FREQUENCY		50 Hz	50 Hz	50 Hz
RUNNING CURRENT	Cooling	2.4 A	3.2 A	4.3 A
	Heating	3.2 A	3.7 A	4.6 A
INPUT WATTS	Cooling	0.470 kW	0.630 kW	0.895 kW
	Heating	0.660 kW	0.750 kW	0.970 kW
E.E.R.	Cooling	4.47 kW/kW	3.97 kW/kW	3.80 kW/kW
COP	Heating	4.55 kW/kW	4.27 kW/kW	4.12 kW/kW
MOISTURE REMOVAL		1.0 L/h	1.3 L/h	1.8 L/h
AIR CIRCULATION HIGH	Cooling	750 m <sup>3</sup> /h	750 m <sup>3</sup> /h	750 m <sup>3</sup> /h
	Heating	750 m <sup>3</sup> /h	750 m <sup>3</sup> /h	750 m <sup>3</sup> /h
MAXIMUM CURRENT	Cooling	6.0 A	6.0 A	6.5 A
	Heating	7.5 A	7.5 A	9.0 A

## FAN MOTOR

POWER SOURCE		230 V	230 V	230 V
INDOOR UNIT Cooling	High speed	1,440 r.p.m.	1,440 r.p.m.	1,440 r.p.m.
	Middle speed	1,200 r.p.m.	1,200 r.p.m.	1,200 r.p.m.
	Low speed	920 r.p.m.	920 r.p.m.	920 r.p.m.
	Quiet	680 r.p.m.	680 r.p.m.	680 r.p.m.
INDOOR UNIT Heating	High speed	1,440 r.p.m.	1,440 r.p.m.	1,440 r.p.m.
	Middle speed	1,200 r.p.m.	1,200 r.p.m.	1,200 r.p.m.
	Low speed	980 r.p.m.	980 r.p.m.	980 r.p.m.
	Quiet	700 r.p.m.	700 r.p.m.	700 r.p.m.
OUTDOOR UNIT	Cooling	730 r.p.m.	730 r.p.m.	860 r.p.m.
OUTDOOR UNIT	Heating	650 r.p.m.	650 r.p.m.	760 r.p.m.

## NOISE LEVEL

INDOOR UNIT Cooling	High speed	43 dB	43 dB	43 dB
	Middle speed	38 dB	38 dB	38 dB
	Low speed	33 dB	33 dB	33 dB
	Quiet	21 dB	21 dB	21 dB
INDOOR UNIT Heating	High speed	43 dB	43 dB	43 dB
	Middle speed	38 dB	38 dB	38 dB
	Low speed	33 dB	33 dB	33 dB
	Quiet	21 dB	21 dB	21 dB
OUTDOOR UNIT	Cooling	45 dB	45 dB	48 dB
OUTDOOR UNIT	Heating	45 dB	45 dB	48 dB

INDOOR UNIT	ASHA07LGC	ASHA09LGC	ASHA12LGC
OUTDOOR UNIT	AOHR07LGC	AOHR09LGC	AOHR12LGC

#### DIMENSIONS

INDOOR UNIT	H x W x D	260 x 790 x 198 mm
OUTDOOR UNIT	H x W x D	540 x 660 x 290 mm

#### WEIGHT

INDOOR UNIT	Gross / Net	10 kg / 7.5 kg	
OUTDOOR UNIT	Gross / Net	28 kg / 25 kg	35 kg / 32 kg

#### COMPRESSOR AND REFRIGERANT

COMPRESSOR TYPE	Hermetic type, 4 pole, 3 phase, DC inverter motor, Rotary			
DISCRIMINATION	5SS072XAA		DA89X1C-20FZ	
WEIGHT (with oil)	5.9 kg		9.9 kg	
STANDARD REFRIGERANT	650 g		800 g	
REFRIGERANT TYPE	R410A		R410A	
FULL CHARGE	Pipe Length	15 m	650 g	800 g
		20 m	750 g	900 g
ADDITIONAL REFRIGERANT	20 g/m			
MAXIMUM PIPING HEIGHT	15m			

# DIMENSIONS

unit : mm

## INDOOR UNIT



## OUTDOOR UNIT

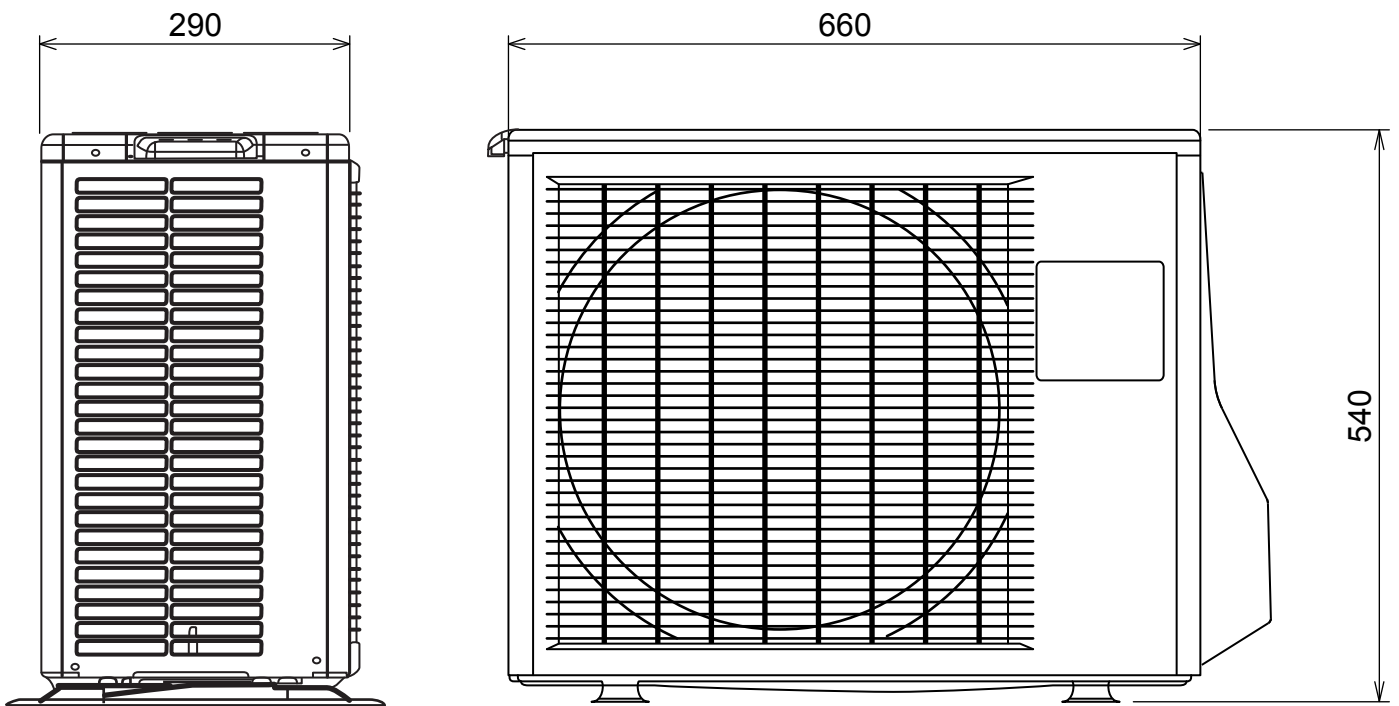

## REFRIGERANT SYSTEM DIAGRAM

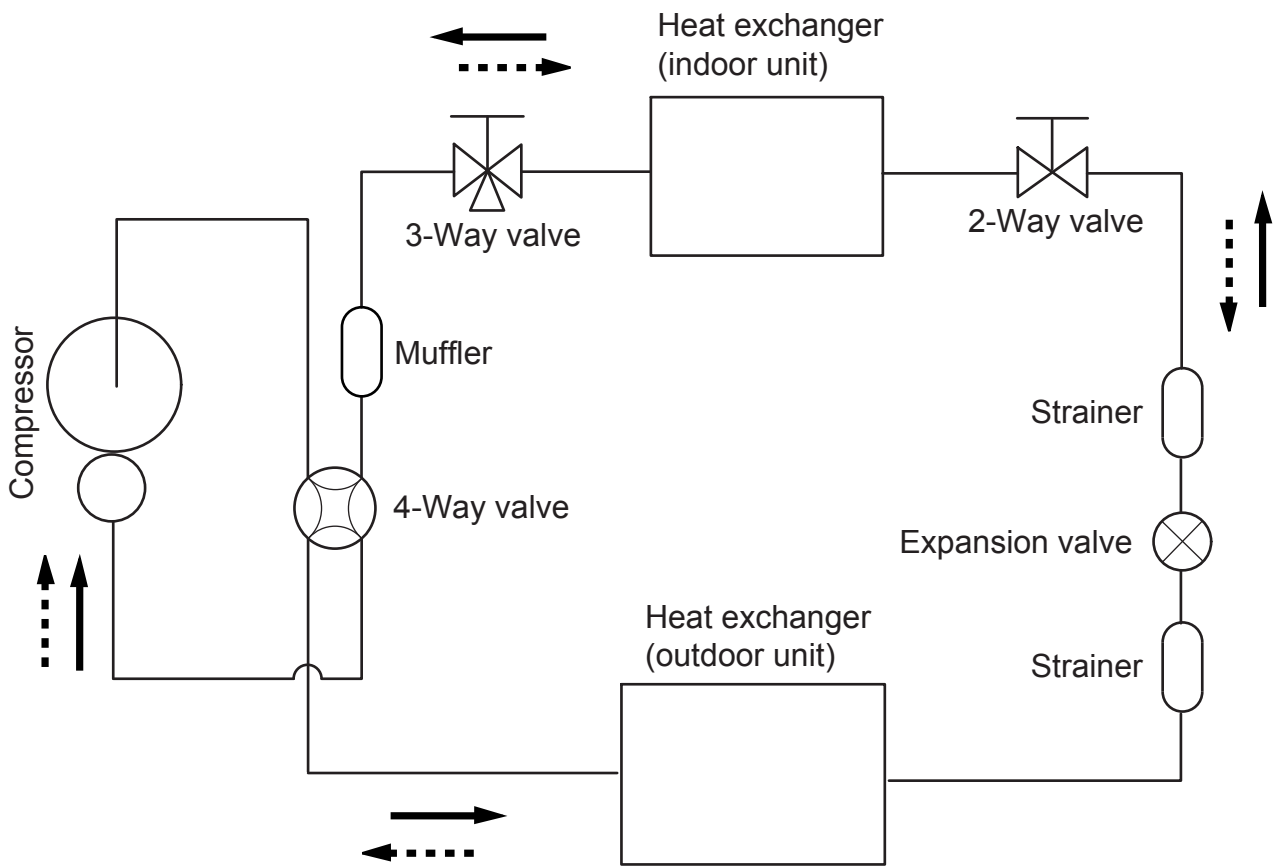

Refrigerant direction

—————▶ Cooling

-----▶ Heating

Refrigerant pipe diameter

Liquid : 1/4" (6.35 mm)

Gas : 3/8" (9.52 mm)

# INDOOR UNIT

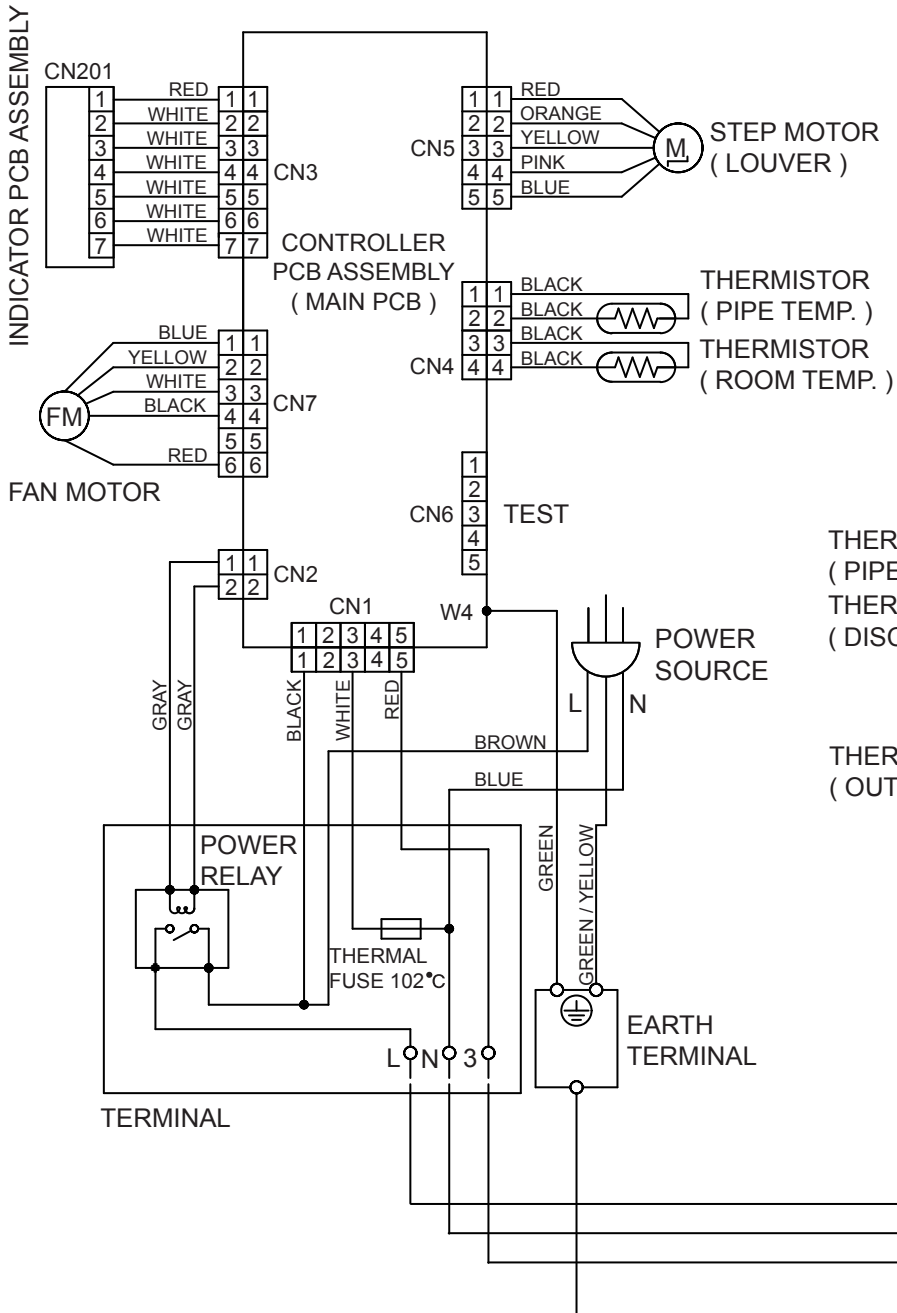

# CIRCUIT DIAGRAM

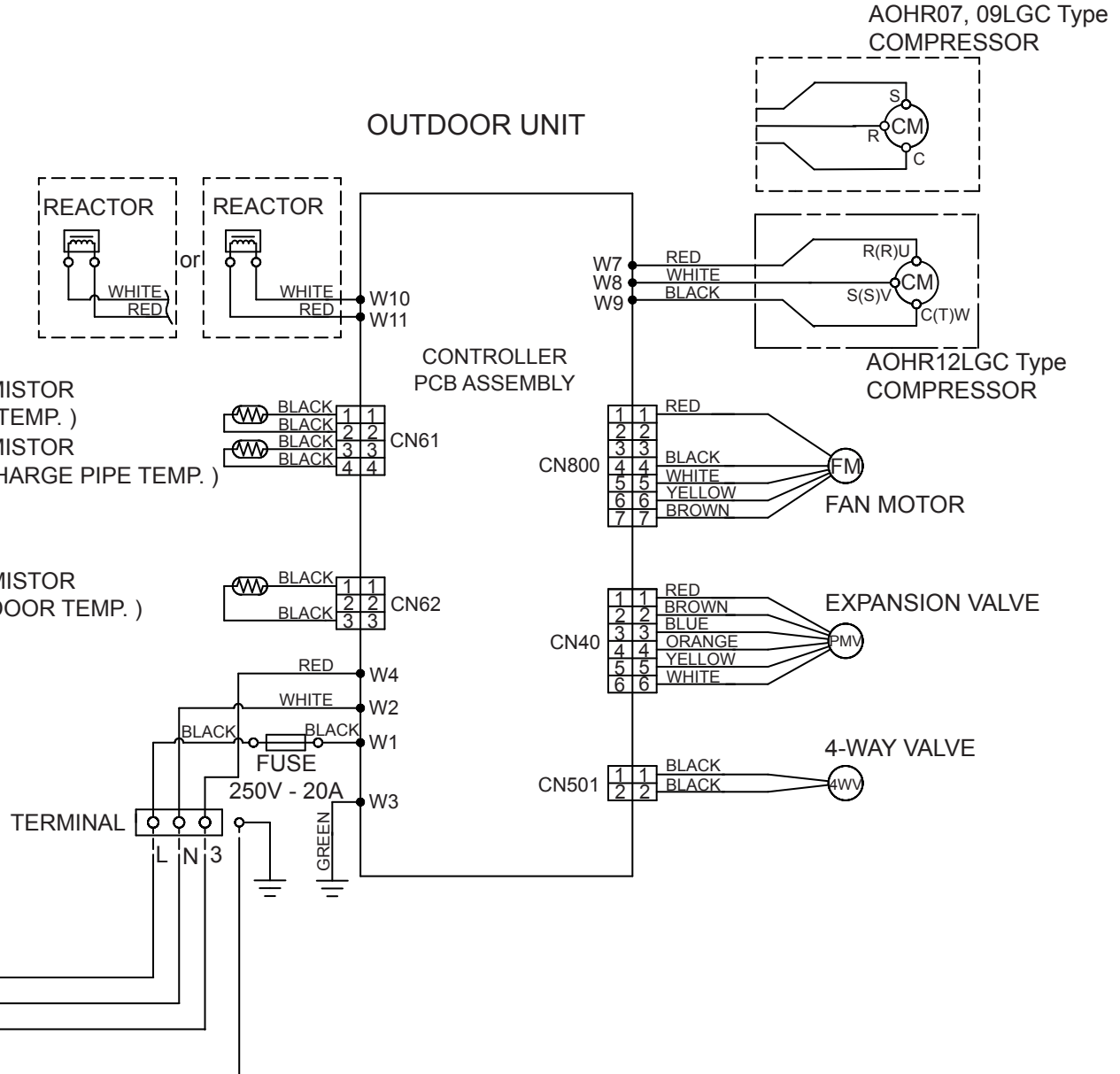

# INDOOR PCB CIRCUIT DIAGRAM

## CONTROL UNIT

ASHA07, 09LGC : EZ-007MHSE

ASHA12LGC : EZ-007PHSE

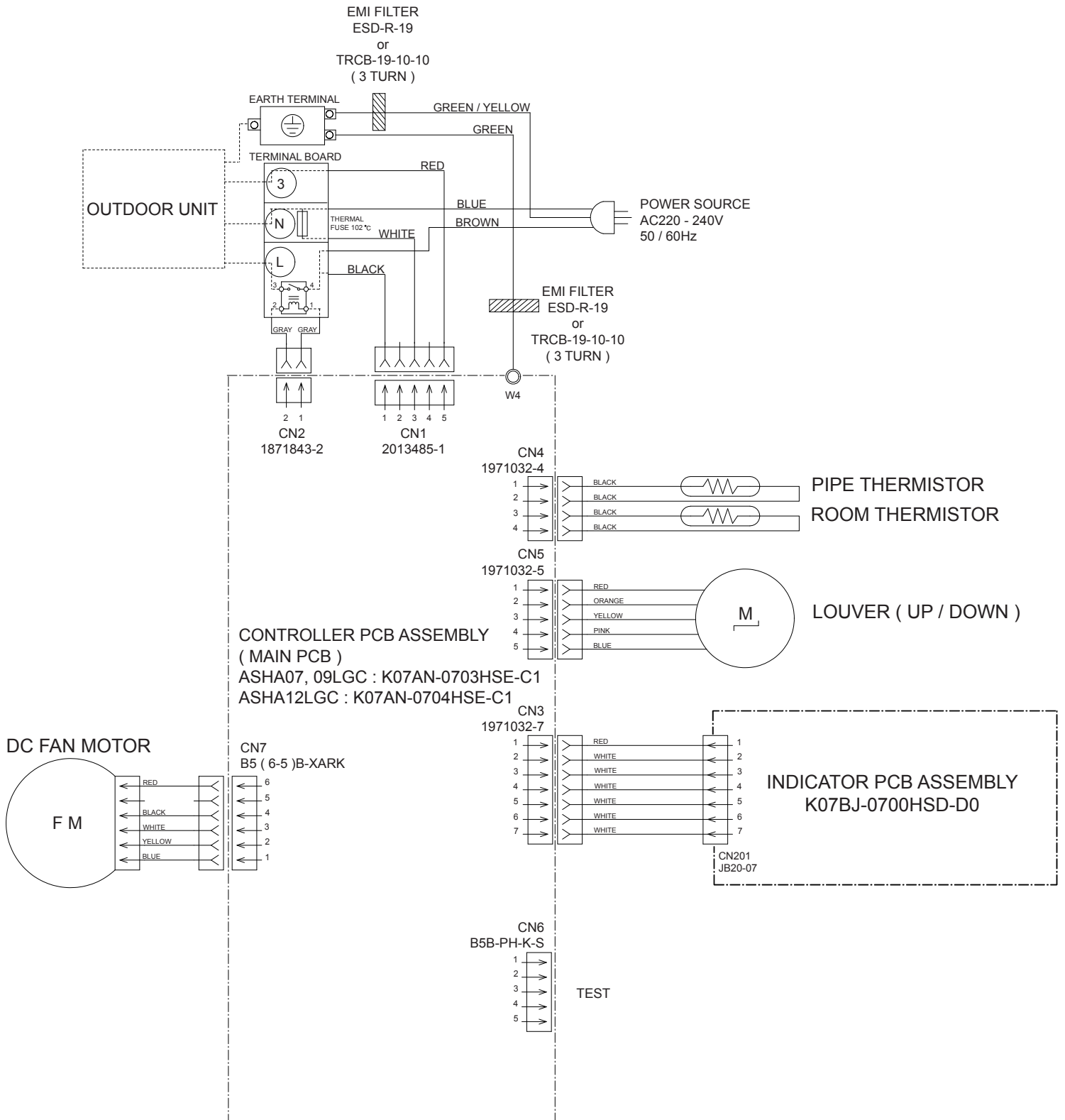

INDOOR UNIT  
 CONTROLLER PCB ASSEMBLY ( MAIN PCB )  
 ASHA07, 09LGC : K07AN-0703HSE-C1  
 ASHA12LGC : K07AN-0704HSE-C1

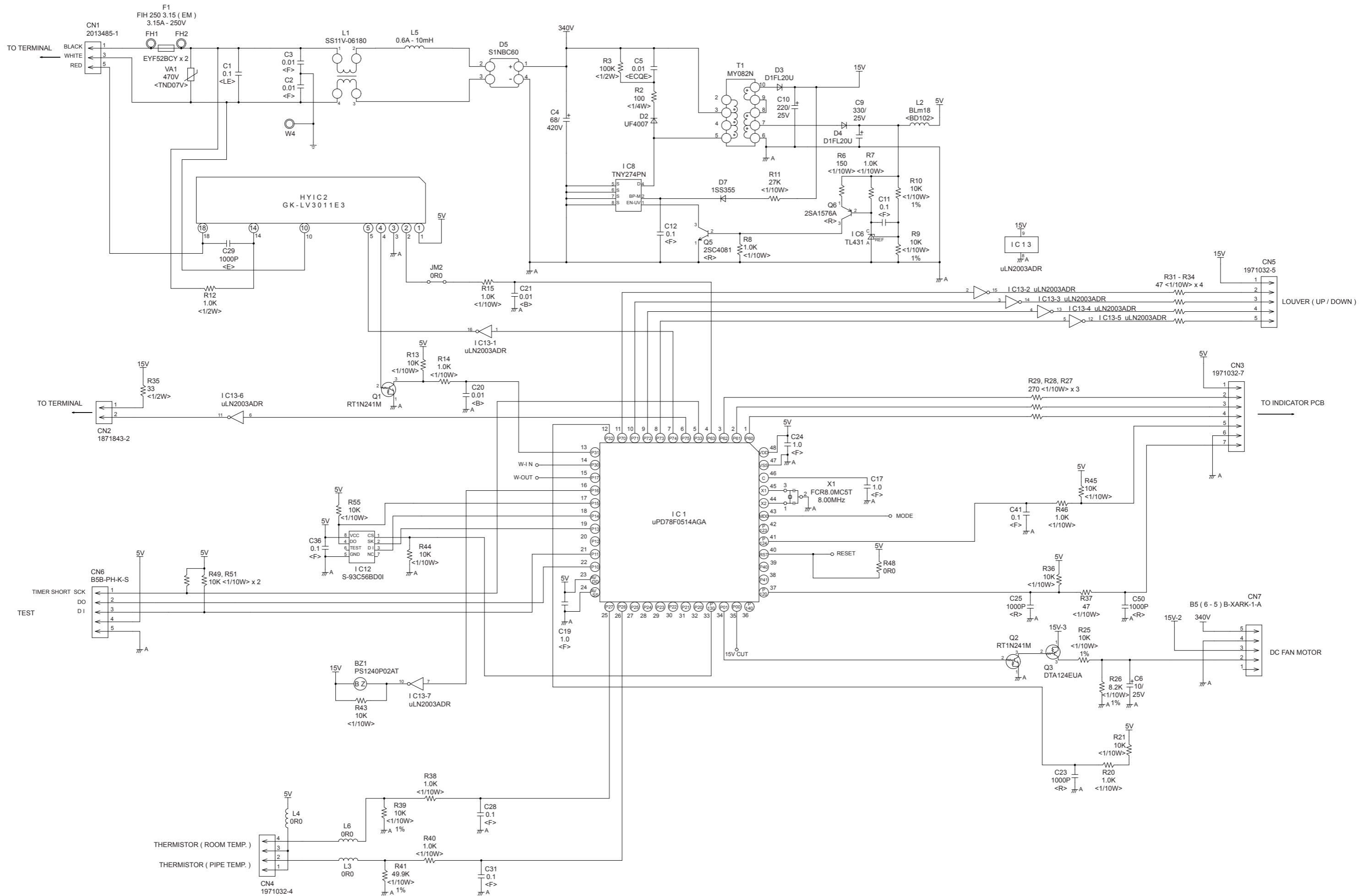





# OUTDOOR PCB CIRCUIT DIAGRAM

INVERTER ASSEMBLY  
 AOHR07LGC : EZ-0080HUE  
 AOHR09LGC : EZ-0075HUE  
 AOHR12LGC : EZ-0076HUE

POWER SOURCE  
 AC230V  
 50Hz

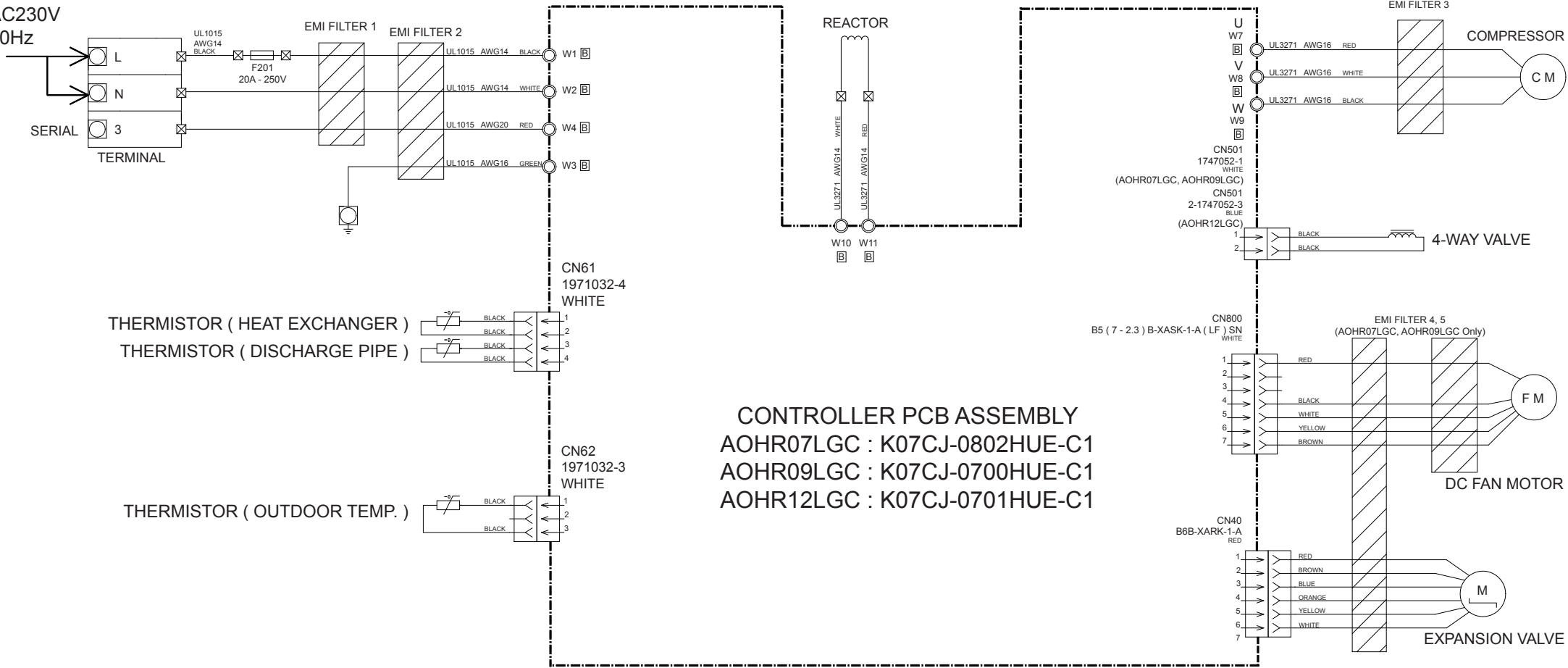

CONTROLLER PCB ASSEMBLY  
 AOHR07LGC : K07CJ-0802HUE-C1  
 AOHR09LGC : K07CJ-0700HUE-C1  
 AOHR12LGC : K07CJ-0701HUE-C1

OUTDOOR UNIT  
 CONTROLLER PCB ASSEMBLY  
 AOHR07LGC : K07CJ-0802HUE-C1  
 AOHR09LGC : K07CJ-0700HUE-C1  
 AOHR12LGC : K07CJ-0701HUE-C1

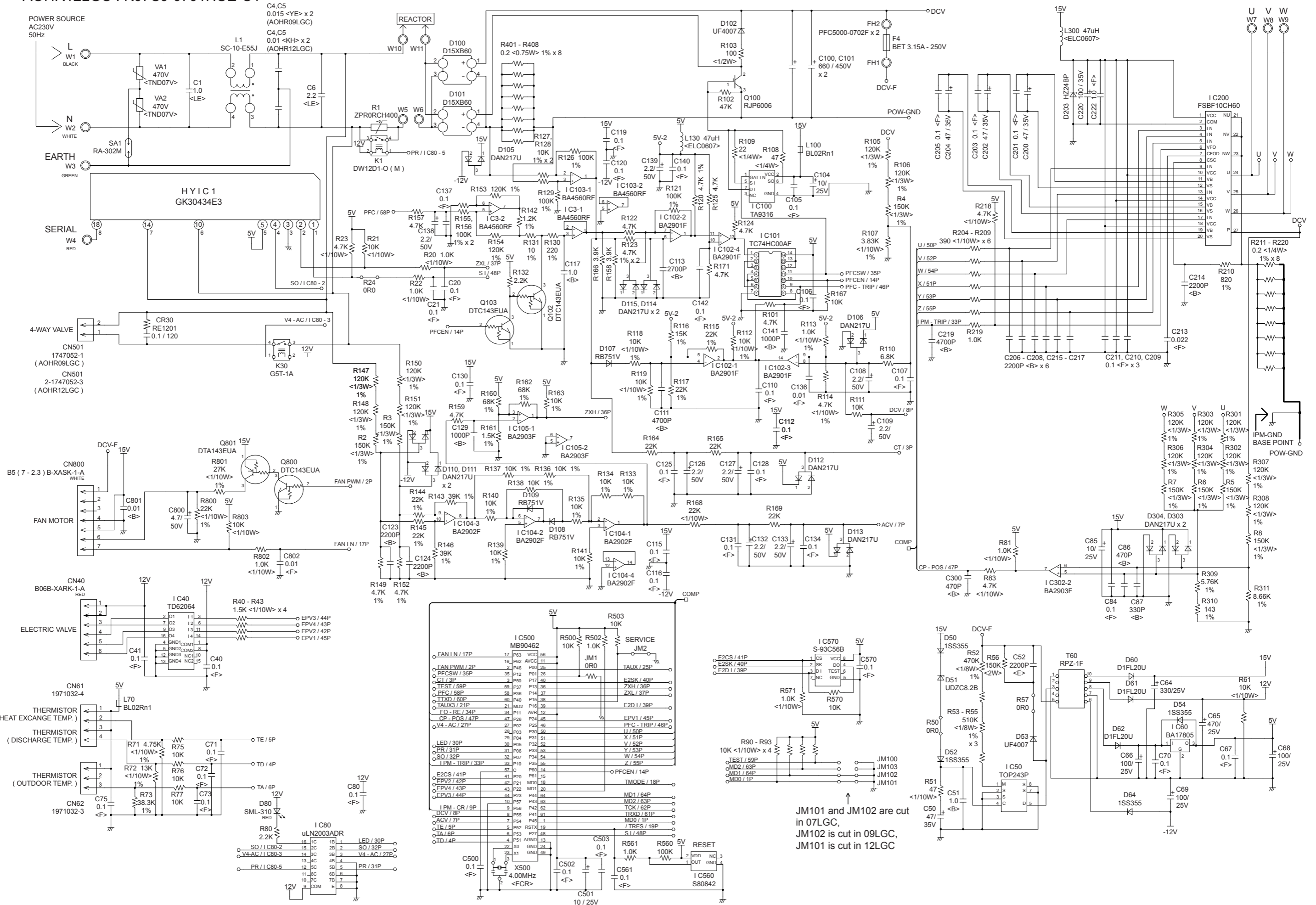

## ERROR CONTENTS

Error	Indoor unit LED			Wired remote control	Error
	Operation LED	Timer LED	Coil dry LED		
Serial signal error	Off	2 flash	off	01	Serial signal (reverse) error, at operation start up
		3 flash	off	01	Serial signal (reverse) error, during operation
		4 flash	off	13	Serial signal (forward) error, at operation start up
		5 flash	off	13	Serial signal (forward) error, during operation
		8 flash	off	00	Wired remote control error
Indoor unit thermistor error	2 flash	2 flash	off	02	Indoor air thermistor error
		3 flash	off	04	Heat exchanger middle thermistor error
Outdoor unit thermistor error	3 flash	2 flash	off	0C	Discharge pipe thermistor error
		3 flash	off	06	Heat exchanger thermistor error
		4 flash	off	0A	Outdoor air thermistor error
Indoor unit control error	4 flash	2 flash	off	20	Manual auto button welded
		3 flash	off	-	Main relay welded
		4 flash	off	2A	Not distinguishing 50Hz or 60Hz
Outdoor unit control error	5 flash	2 flash	off	17	Current trip error
		3 flash	off	18	CT abnormal
		5 flash	off	1A	Compressor location detection error
		6 flash	off	1B	Outdoor unit fan drive system abnormal
Indoor fan motor error	6 flash	2 flash	off	12	Abnormal lock (upper fan motor)
		3 flash	off	12	Abnormal rotation (upper fan motor)
Refrigerant cycle error	7 flash	2 flash	off	0F	Discharge temperature abnormal
		3 flash	off	24	Cooling high pressure abnormal rise
		4 flash	off	2C ?	DC 4-way valve and expansion valve abnormal
Optional function error	8 flash	4 flash	off	25	PFC circuit error
Model information error	0.1 sec on/off	0.1 sec on/off	0.1 sec on/off	11	Model information error

# PARTS

## INDOOR UNIT Front panel assy

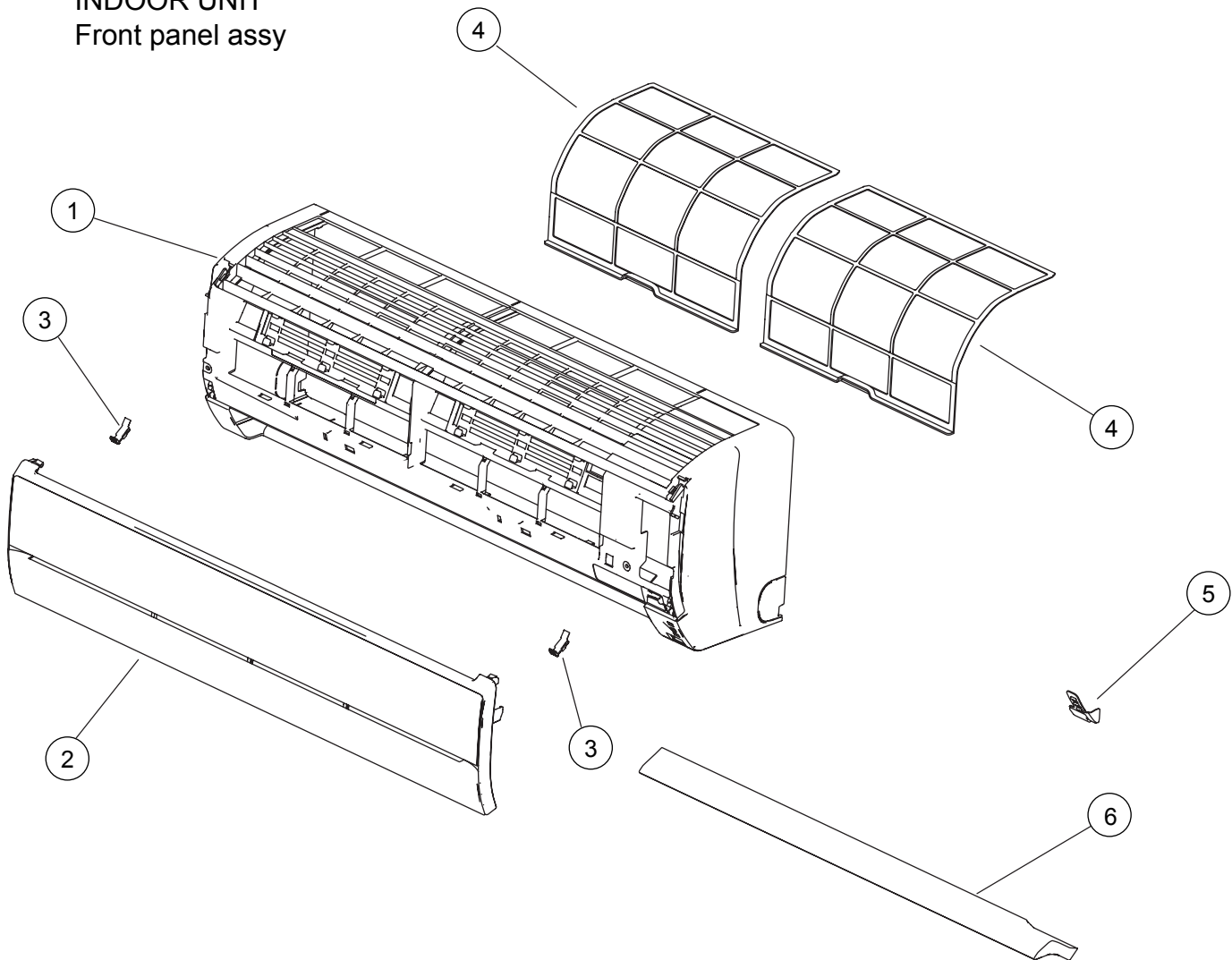

Ref.	Description	Part number
1	Front Panel	9316558014
2	Intake Grille	9316560024
3	Clamper (Grille)	9316906006
4	Air Filter	9316562004
5	Receiver Window	9316588004
6	Panel Cover	9316561007
7	Remote Control	9316397026
8	Remote Control Holder	9305642045
--	Air Clean Filter Assy	9317250009
--	Wire Cover	9316559004
--	Wire Shield	9316584006

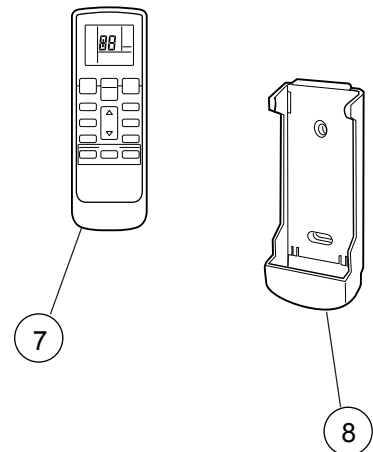

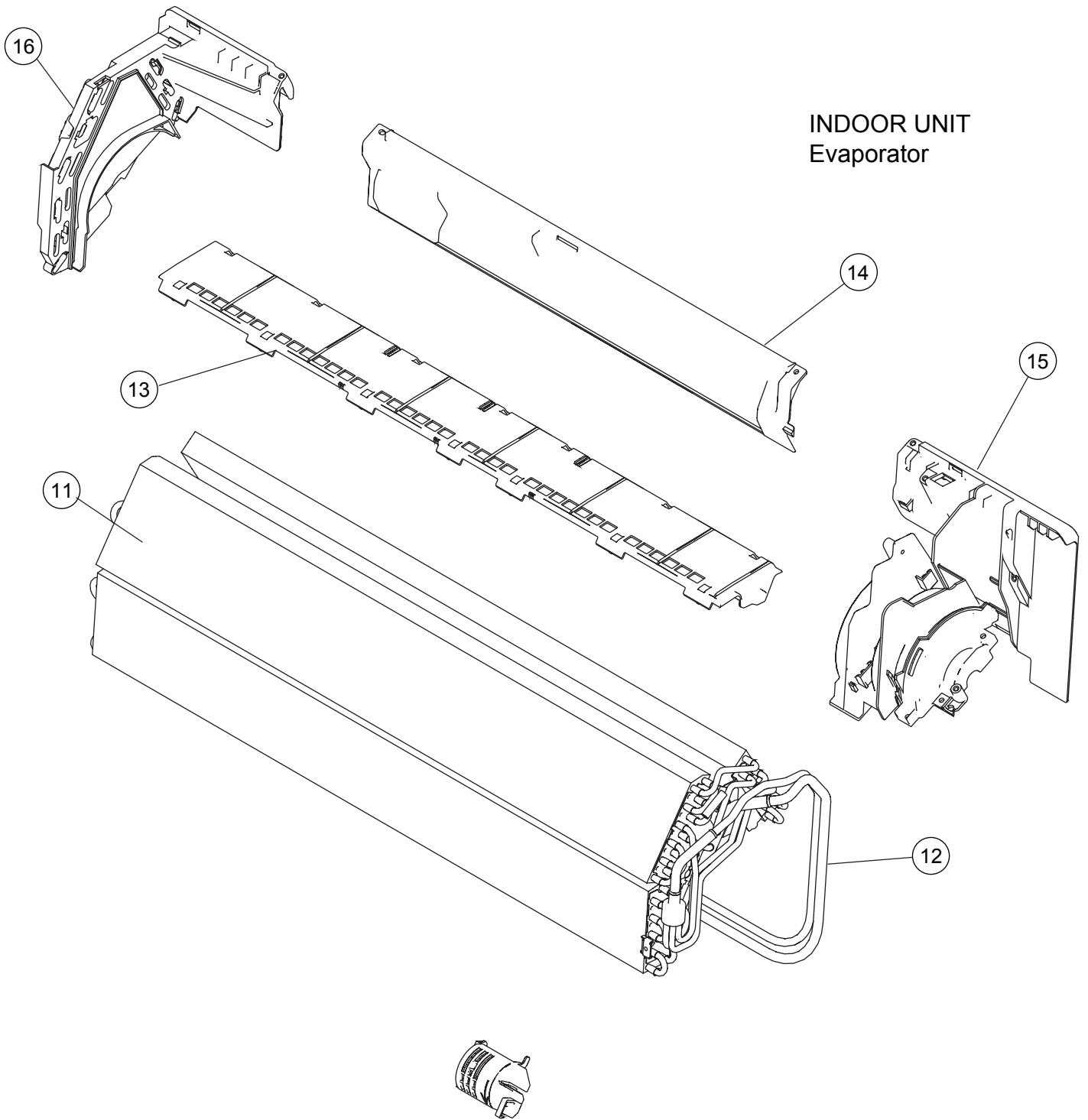

Ref.	Description	Part number
11	Evaporator Assy (07, 09)	9316922013
11	Evaporator Assy (12)	9317268011
12	Joint Pipe Assy (07, 09)	9316923010
12	Joint Pipe Assy (12)	9317190015
13	Filter Guide	9316578005
14	Rear Bracket	9316566002
15	Evaporator Holder R	9316565005
16	Evaporator Holder L	9316564008

INDOOR UNIT  
Casing assy

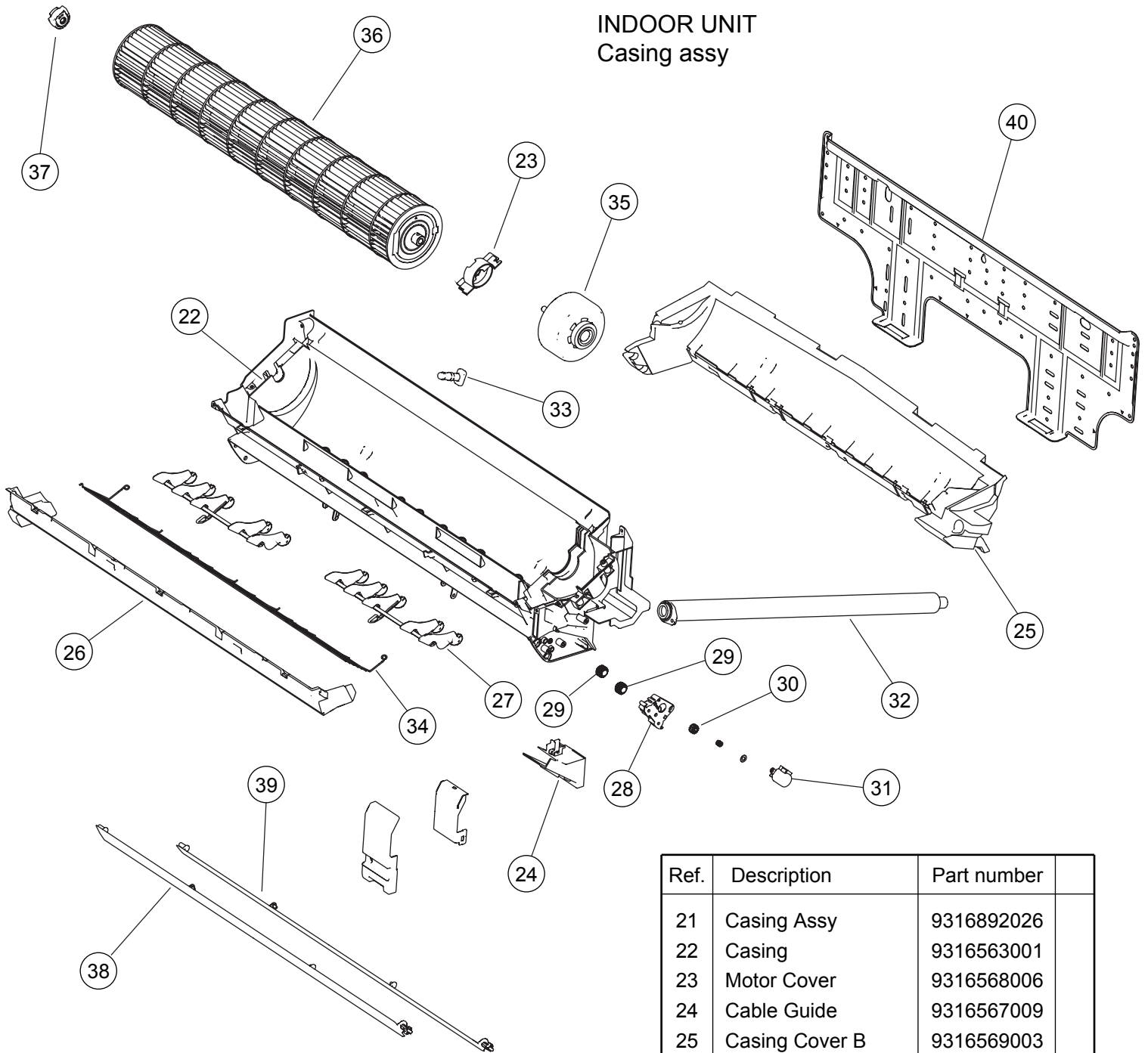

Ref.	Description	Part number
21	Casing Assy	9316892026
22	Casing	9316563001
23	Motor Cover	9316568006
24	Cable Guide	9316567009
25	Casing Cover B	9316569003
26	Casing Cover F	9316570009
27	R and L Louver B	9316961005
28	Louver Gear Holder	9316575004
29	Louver Gear	9316574007
30	Gear A	9309994003
31	Motor Step	9900139117
32	Drain Hose Assy	9316904002
33	Drain Cap	9316177017
34	Fan Guard	9317182003
35	Fan Motor	9602704002
36	Crossflow Fan Assy	9316830004
37	Shaft Holder C	9306628017
38	Louver U	9316572003
39	Louver Z	9316573000
40	Bracket Panel	9316590007

INDOOR UNIT  
Control box

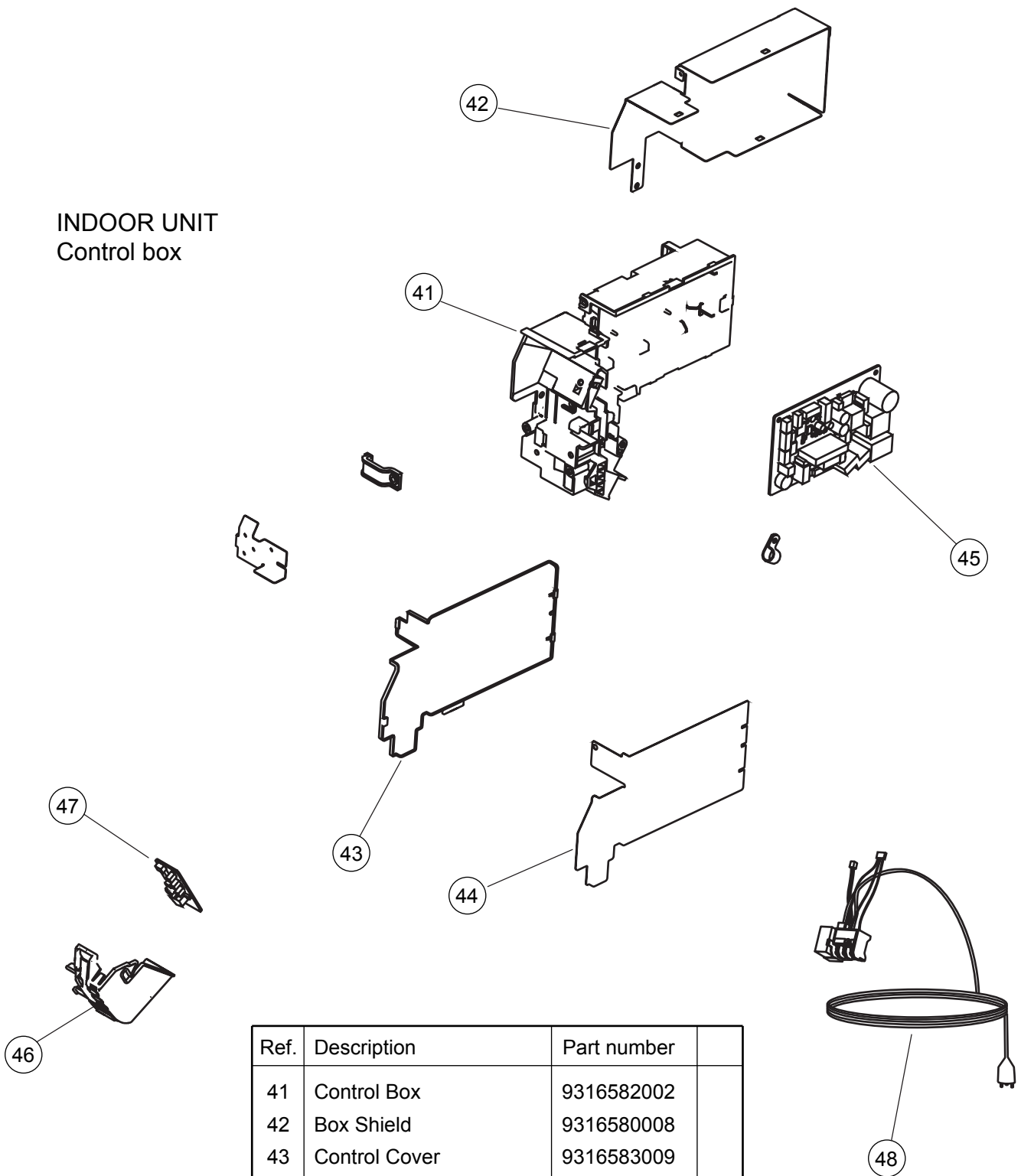

Ref.	Description	Part number
41	Control Box	9316582002
42	Box Shield	9316580008
43	Control Cover	9316583009
44	Cover Shield	9316581005
45	Controller PCB Assy (07, 09)	9707645040
45	Controller PCB Assy (12)	9707645057
46	Display Case	9316587007
47	Display PCB Assy	9707649017
48	Power Cord Assy	9900456016
--	Earth Terminal	9316586000
--	Thermistor Assy	9900459000
--	Room Thermistor Holder	9316895003



# PARTS

OUTDOOR UNIT  
AOHR07LGC  
AOHR09LGC  
AOHR12LGC

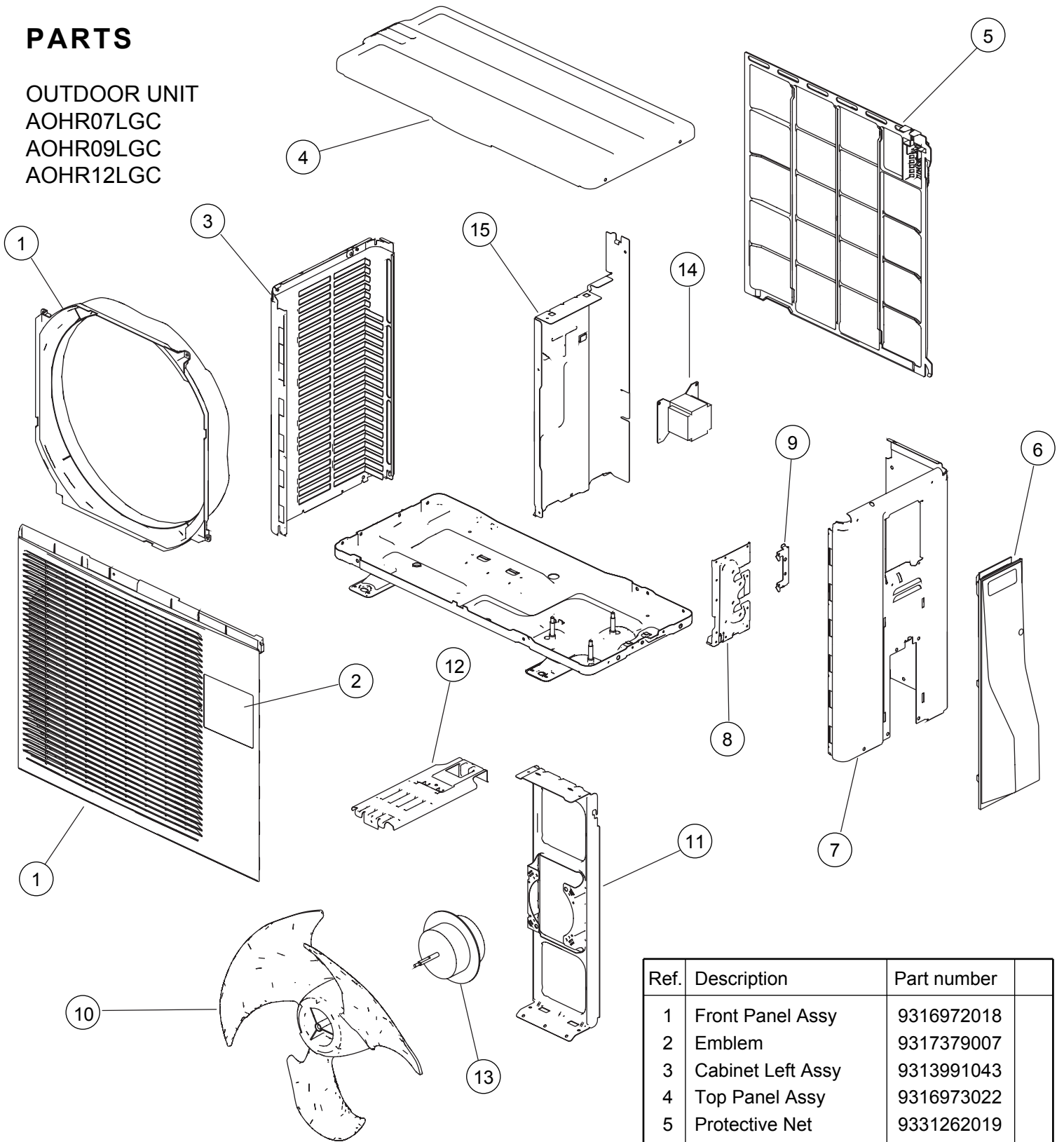

9602873005  
SERVICE KIT (MOTOR)  
  
SEE THE SERVICE  
BULLETIN

Ref.	Description	Part number
1	Front Panel Assy	9316972018
2	Emblem	9317379007
3	Cabinet Left Assy	9313991043
4	Top Panel Assy	9316973022
5	Protective Net	9331262019
6	Switch Cover	9310979020
7	Cabinet Right Assy	9331336055
8	Valve Bracket	9316523012
9	Valve Bracket Cover	9331683005
10	Propeller Fan	9309909014
11	Motor Bracket	9316538009
12	REM Plate Assy (07, 09)	9316967038
12	REM Plate Assy (12)	9316967021
13	Fan Motor (07, 09)	9602706013
13	Fan Motor (12)	9602751013
14	Reactor Assy	9900357023
15	Separator Assy	9317392006

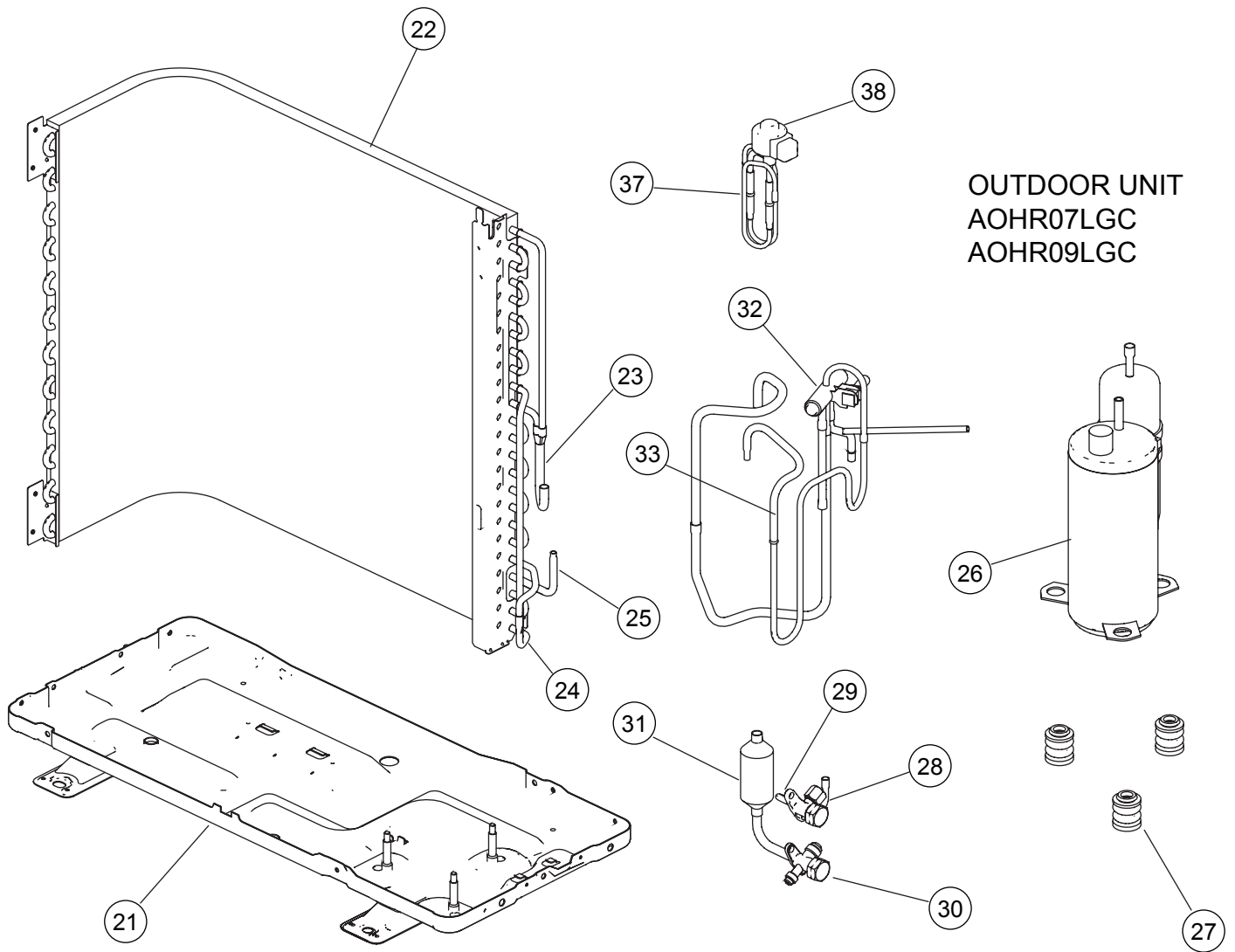

Ref.	Description	Part number
21	Base Assy	9316916005
22	Condenser Assy	9317286008
23	Entrance Pipe Assy (Cond)	9317163019
24	Separate Pipe Assy (Cond)	9317152013
25	Exit Pipe	9317338004
26	Compressor Assy	9317083010
27	Cushion	9306410001
28	2 way Valve Assy	9317171014
29	Joint Pipe (2 way Valve)	9317344005
30	3 way Valve Assy	9317174015
31	Muffler	9317394000
32	4 way Valve	9970074011
33	Discharge Pipe Assy	9317159012
37	Pulse Motor Valve Assy	9317216005
38	Expansion Valve Coil	9900057039
--	Solenoid	9970077012
--	Condenser Total Assy	9317287012
--	4 way Valve Assy	9317158015
--	Insulator B	9317400015
--	Insulator F	9331460019
--	Insulator H	9317401012

OUTDOOR UNIT  
AOHR12LGC

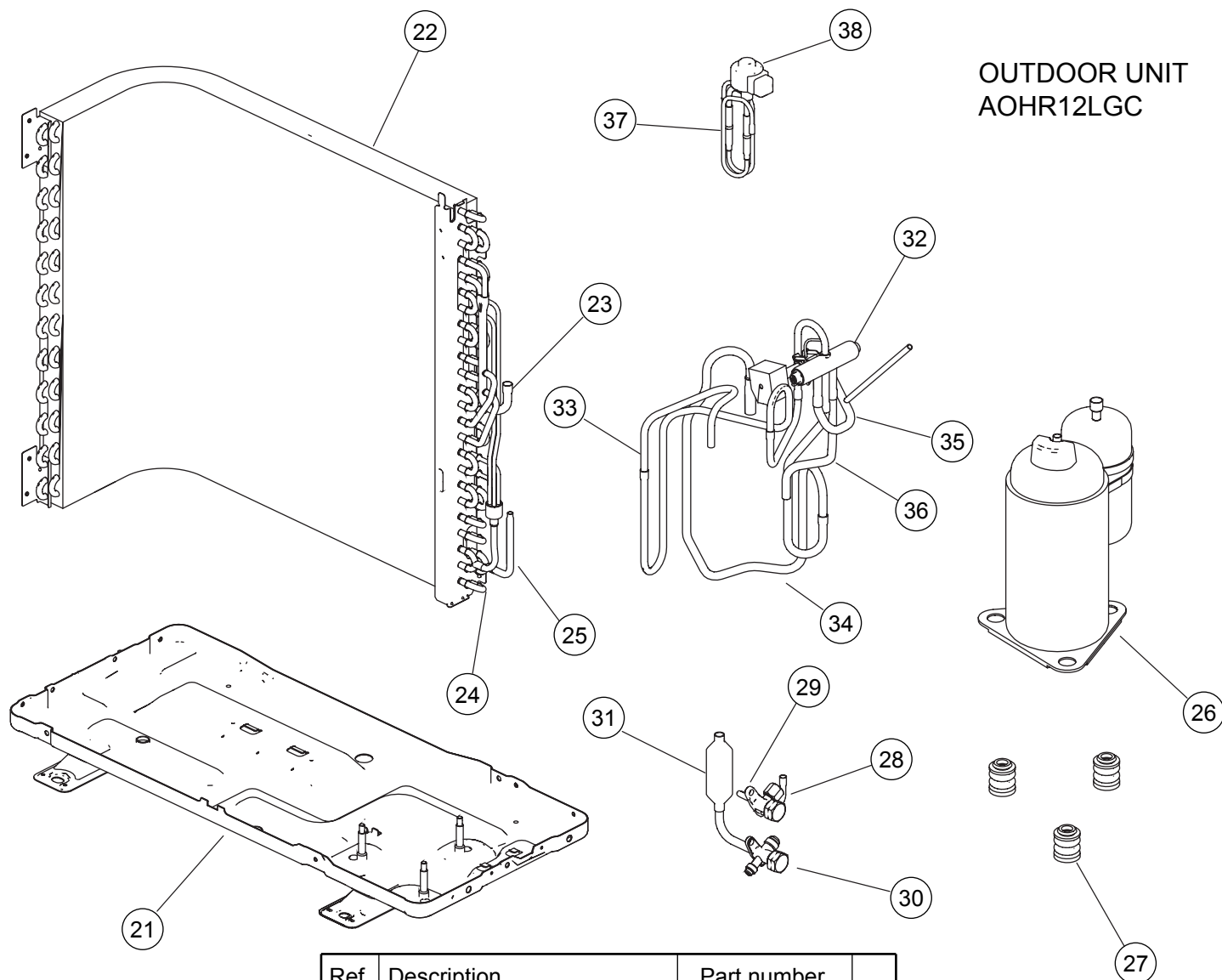

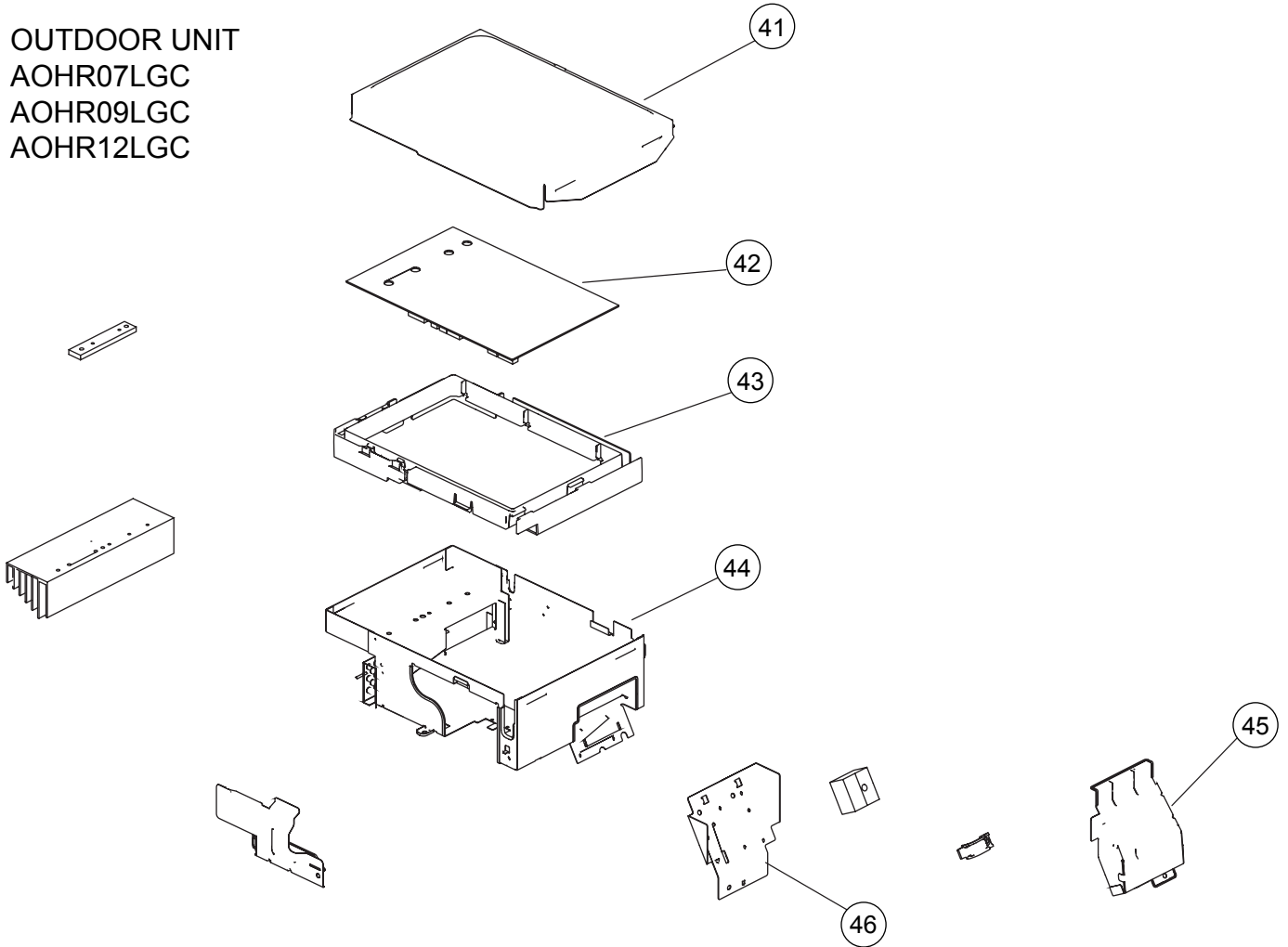

Ref.	Description	Part number
21	Base Assy	9316980006
22	Condenser Assy	9317193016
23	Entrance Pipe Assy (Cond)	9317194013
24	Separate Pipe Assy (Cond)	9317200011
25	Exit Pipe	9317239004
26	Compressor Assy	9315206015
27	Cushion	9306410001
28	2 way Valve Assy	9317171014
29	Joint Pipe (2 way Valve)	9317344005
30	3 way Valve Assy	9317174015
31	Muffler	9317398008
32	4 way Valve	9900162016
33	Discharge Pipe Assy	9317279000
34	Suction Pipe Assy	9317282017
35	Joint Pipe Assy (Cond)	9317396011
36	Joint Pipe (3 way Valve)	9317214001
37	Pulse Motor Valve Assy	9317216005
38	Expansion Valve Coil	9900057039
--	Solenoid	9970055027
--	Condenser Total Assy	9317192019
--	4 way Valve Assy	9317278010
--	Insulator B	9317321006
--	Insulator F	9317403009
--	Insulator H	9317322003

OUTDOOR UNIT  
 AOHR07LGC  
 AOHR09LGC  
 AOHR12LGC

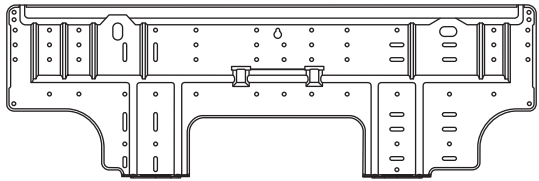

Ref.	Description	Part number	
41	Sealed Panel	9331256018	
42	Controller PCB Assy (07)	9707706086	
42	Controller PCB Assy (09)	9707706017	
42	Controller PCB Assy (12)	9707706024	
43	PCB Holder	9331261012	
44	Inverter Case Assy	9331279017	
45	Terminal Cover	9331269025	
46	Terminal	9306489168	
--	Outdoor Thermistor	9900452025	
--	Thermistor Assy	9900451059	

## ACCESSORIES

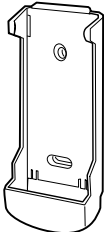
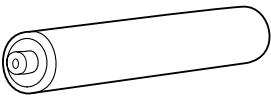
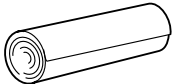
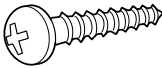
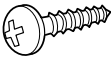
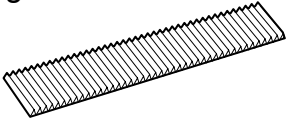
Name and Shape	Part number
<p>Wall hook bracket</p> 	<p>9316590007</p>
<p>Remote control</p> 	<p>9316397026</p>
<p>Remote control holder</p> 	<p>9305642045</p>
<p>Battery (penlight)</p> 	<p>0600185527</p>
<p>Cloth tape</p> 	<p>9310519004</p>
<p>Tapping screw (big) (<math>\phi</math> 4 x 25)</p> 	<p>0700076046</p>
<p>Tapping screw (small) (<math>\phi</math> 3 x 12)</p> 	<p>0700019036</p>
<p>Air cleaning filter</p> 	<p>9311925088 9312153077</p>

0801G3345