

**SPLIT TYPE
AIR CONDITIONER
DUCT type (50Hz)**

**SERVICE
MANUAL**

Models

Indoor unit

Outdoor unit

ARY36UUAN

AOY36UMAXL



CONTENTS

SPECIFICATIONS	1
DIMENSIONS	2
REFRIGERANT SYSTEM DIAGRAM	4
CIRCUIT DIAGRAM	5
INDOOR PCB CIRCUIT DIAGRAM	6
OUTDOOR PCB CIRCUIT DIAGRAM	7
ERROR CONTENTS	8
DISASSEMBLY ILLUSTRATION	9
PARTS LIST	16
STANDARD ACCESSORIES	18

SPECIFICATIONS

TYPE	COOLING & HEATING
INDOOR UNIT	ARY36UUAN
OUTDOOR UNIT	AOY36UMAXL
COOLING CAPACITY	10.5 kW
HEATING CAPACITY	12.7 kW

ELECTRICAL DATA

POWER SOURCE	1 - 230 V 50 Hz	
RUNNING CURRENT	COOLING	16.0 A
	HEATING	16.5 A
INPUT WATTS	COOLING	3.60 kW
	HEATING	3.65 kW
POWER FACTOR	COOLING	97.8 %
	HEATING	96.2 %
E.E.R.	COOLING	2.92 kW/kW
	HEATING	3.48 kW/kW
STARTING CURRENT	96 A	
MOISTURE REMOVAL	3.5 L/hr	
AIR CIRCULATION-HIGH	INDOOR	1,750 m3/hr
	OUTDOOR	6,100 m3/hr

COMPRESSOR

TYPE	Hermetic type, 2 poles, 3 phase, Induction motor, Twin Rotary	
DISCRIMINATION	NN40VAEMT	
REFRIGERANT	R410A	3,100 g

FAN MOTOR

INDOOR UNIT	DISCRIMINATION	MFA-45 PTAT
	HIGH-SPEED	1,340 r.p.m.
	MED-SPEED	1,280 r.p.m.
	LOW-SPEED	1,210 r.p.m.
OUTDOOR UNIT	DISCRIMINATION	MFB-30PTT
	HIGH-SPEED	780 r.p.m.
	LOW-SPEED	400 r.p.m.

DIMENSIONS

INDOOR UNIT	H x W x D	270 x 1,135 x 700 mm
OUTDOOR UNIT	H x W x D	1,165 x 900 x 330 mm

WEIGHT

INDOOR UNIT	GROSS / NET	50 / 43 kg
OUTDOOR UNIT	GROSS / NET	105 / 98 kg

NOISE LEVEL

INDOOR UNIT	HIGH-SPEED	43 dB
	MED-SPEED	41 dB
	LOW-SPEED	39 dB
OUTDOOR UNIT	COOL	54 dB
	HEAT	55 dB

Note : Static pressure : 100Pa

Duct length : Inlet 1m, Outlet 2m

REFRIGERANT CHARGE (R410A)

MAX PIPE LENGTH	50 m		
MAX PIPE HEIGHT	30 m		
FULL CHARGE AMOUNT	Pipe Length	20 m	3,100 g
		30 m	3,400 g
		40 m	3,700 g
		50 m	4,000 g
ADDITIONAL REFRIGERANT	30 g / m		

DIMENSIONS

INDOOR UNIT

Model :
ARY36UUAN

(Unit : mm)

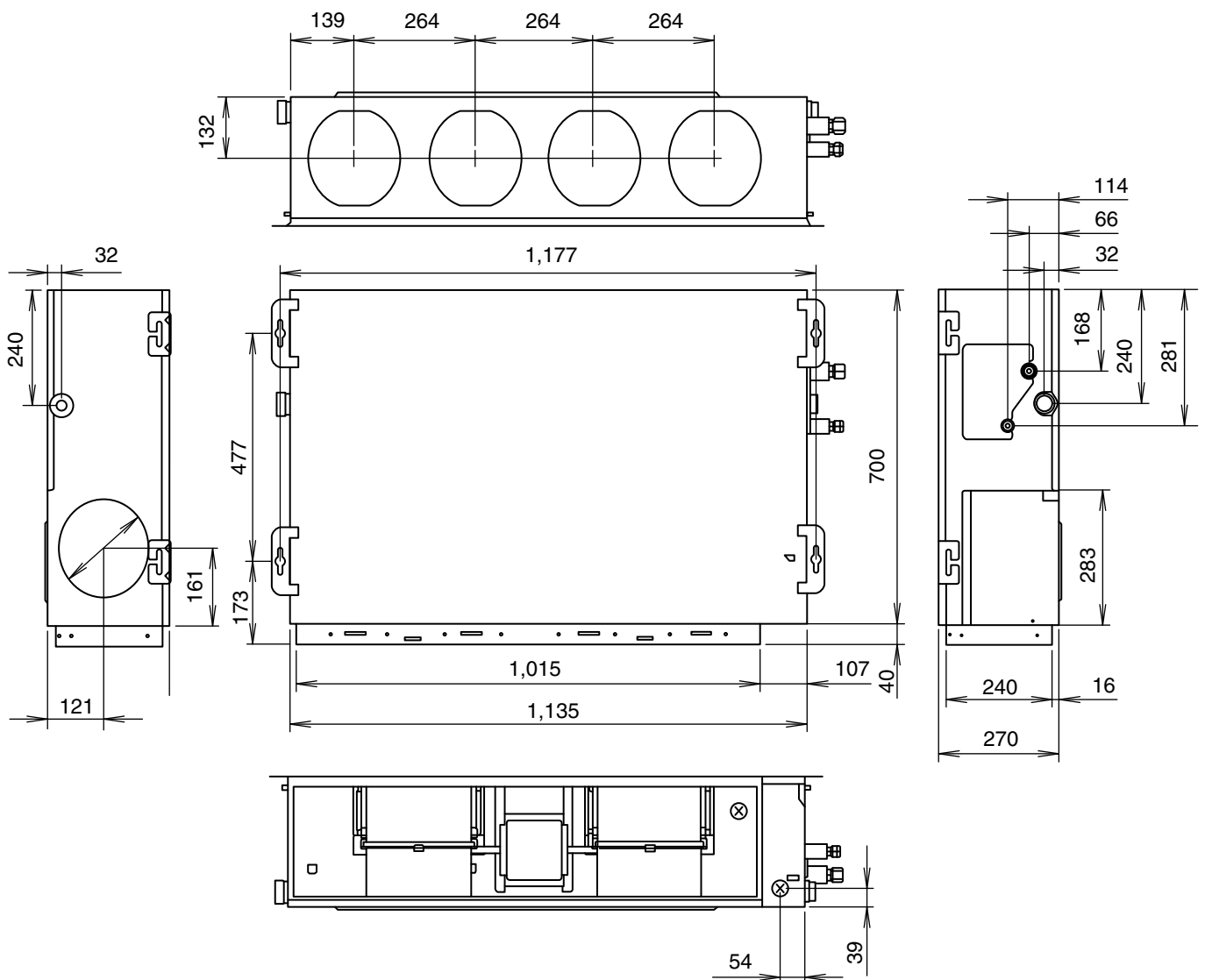

OUTDOOR UNIT

Model : AOY36UMAXL

(Unit : mm)

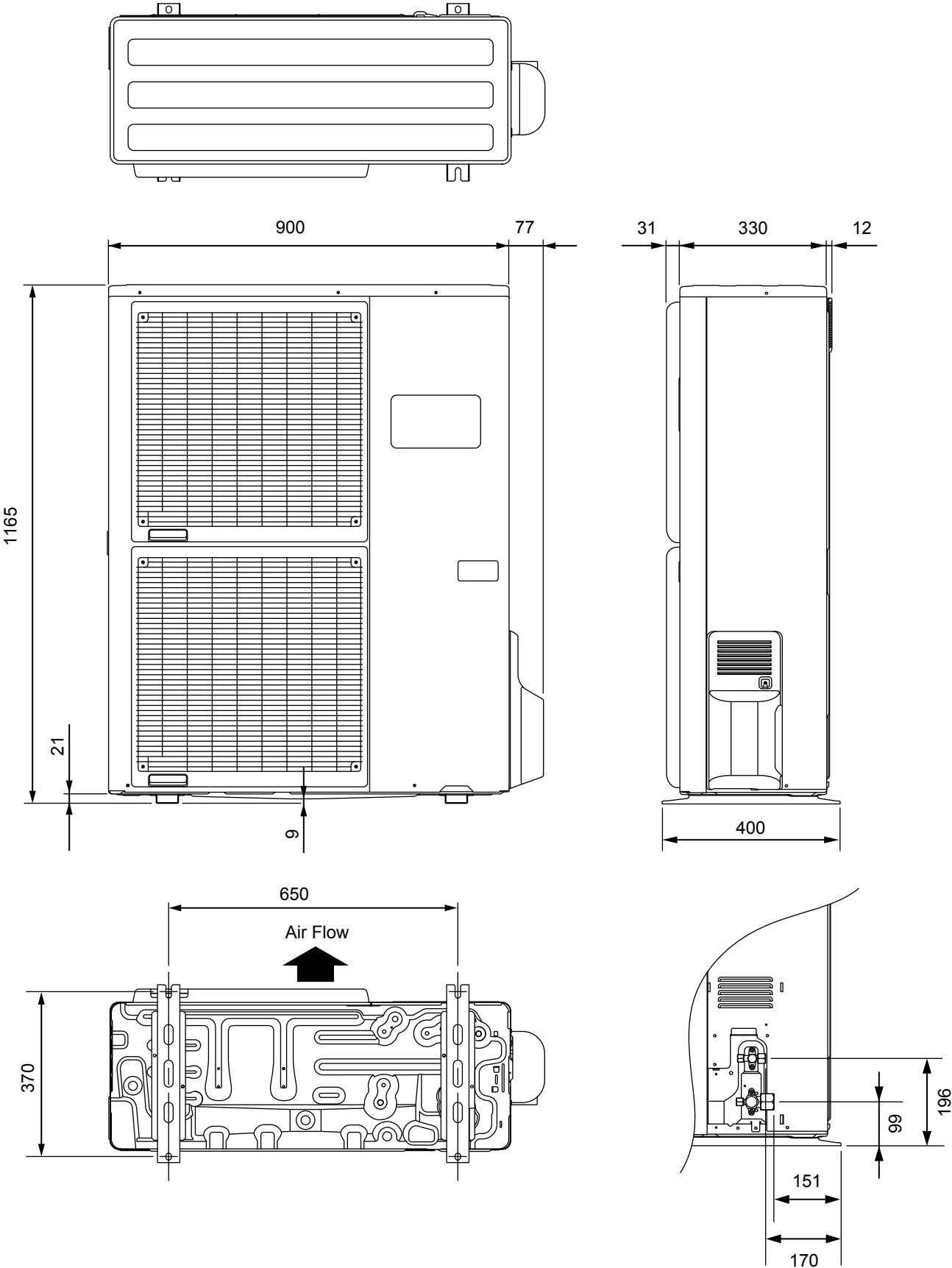

REFRIGERANT SYSTEM DIAGRAM

Models : ARY36UUAN / AOY36UMAXL

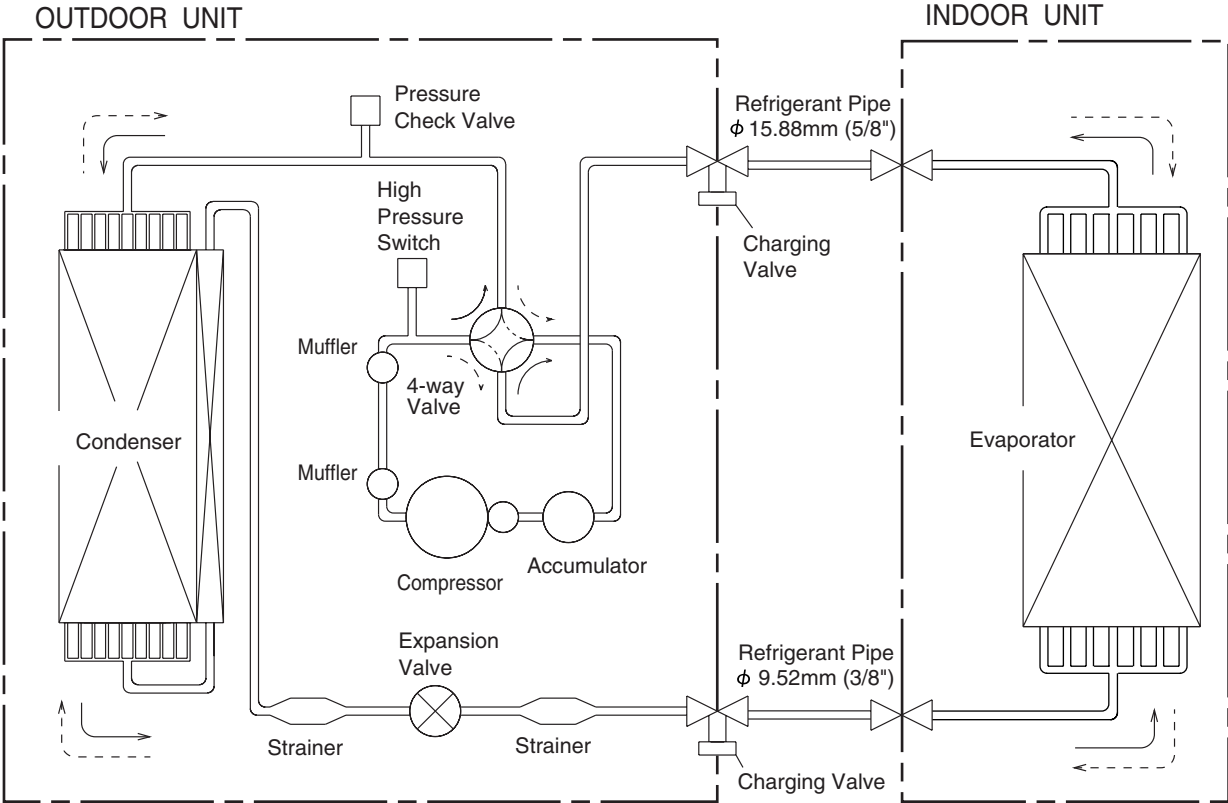

—> : COOL
 - - -> : HEAT

CIRCUIT DIAGRAM

Model : ARY36UUAN

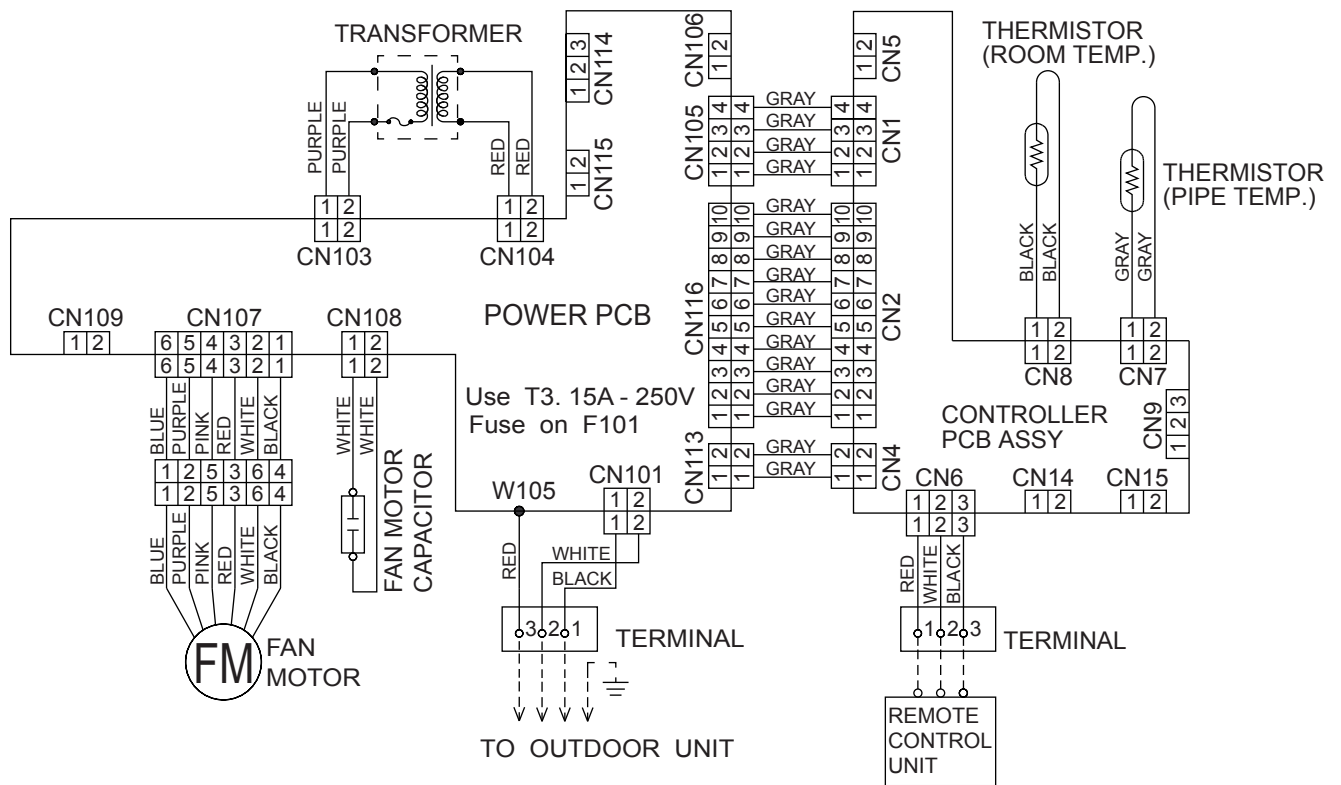

Model : AOY36UMAXL

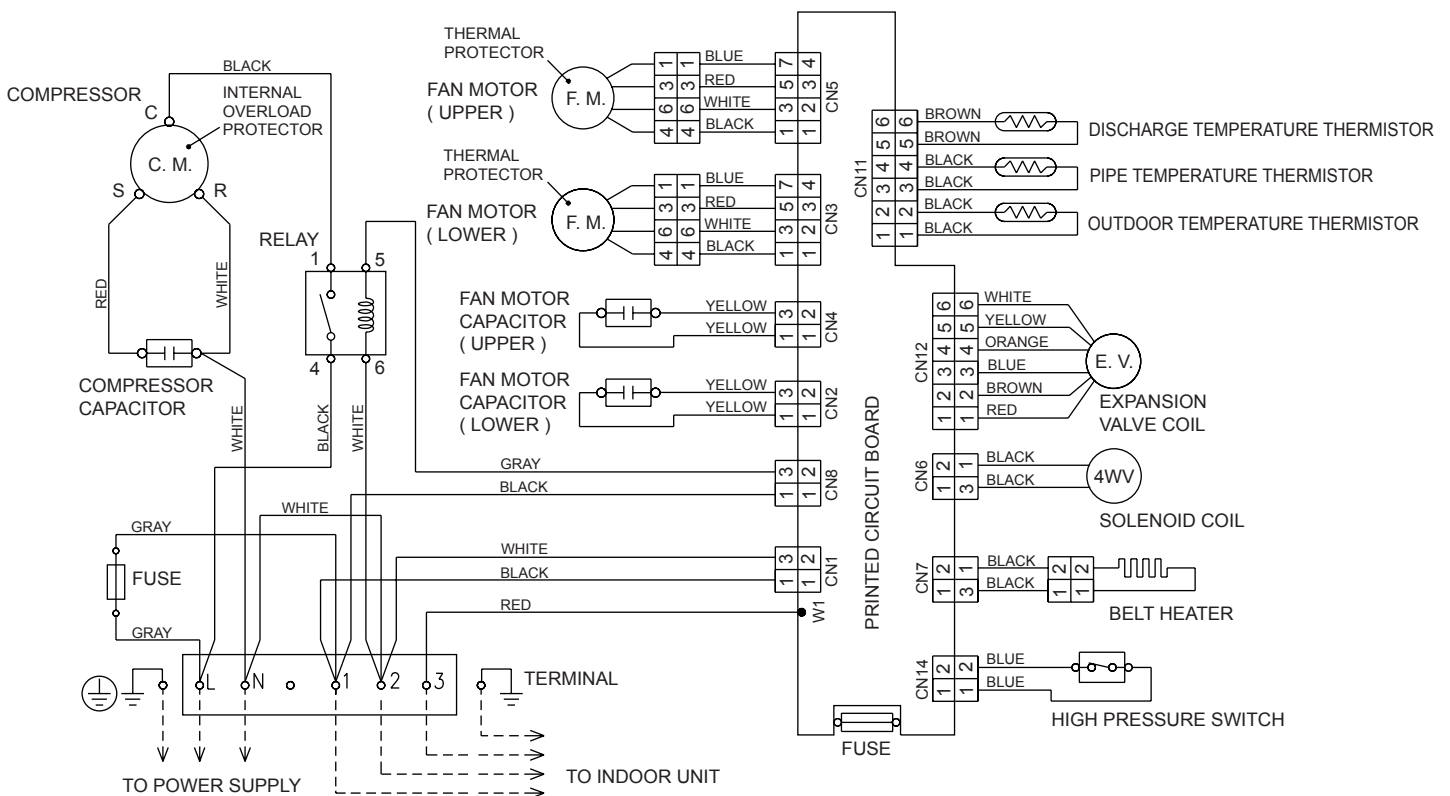

INDOOR PCB CIRCUIT DIAGRAM

Model : ARY36UUAN

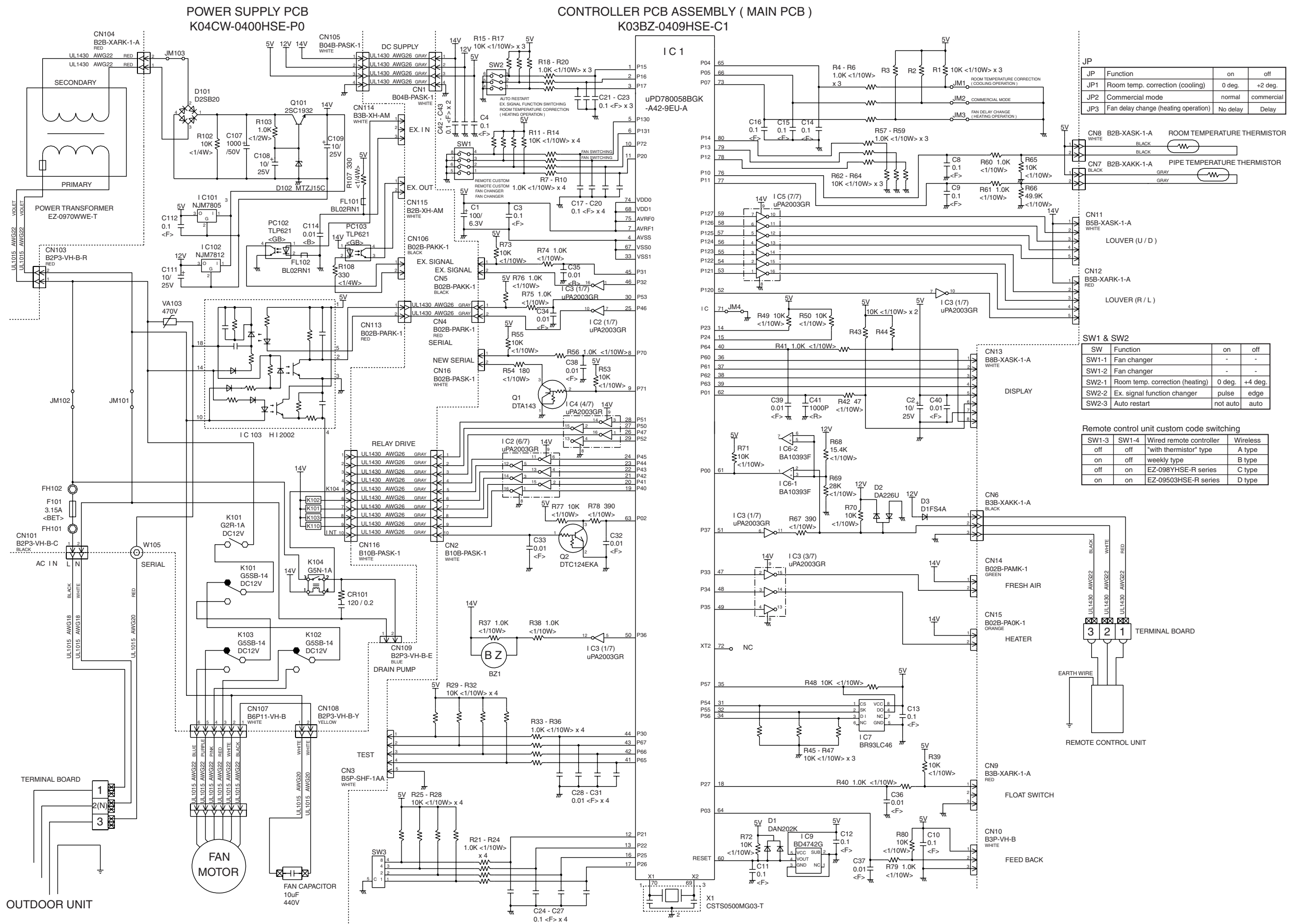

OUTDOOR PCB CIRCUIT DIAGRAM

Model : AOY36UMAXL

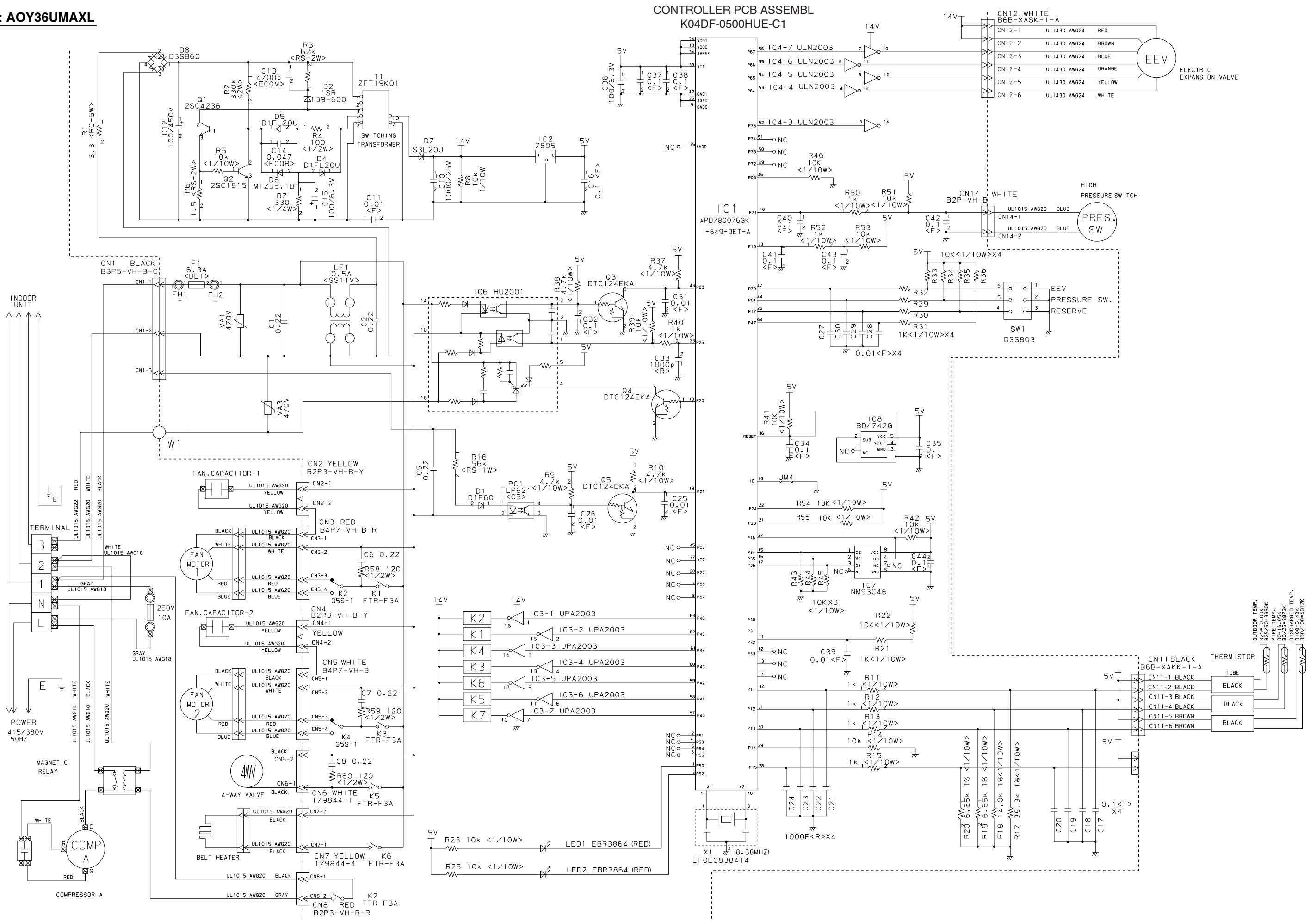

CONTROLLER PCB ASSEMBLY K04DF-0500HUE-C1

ERROR CONTENTS

- (1) Stop the air conditioner operation.
- (2) Press the master control button and the fan control button simultaneously for 2 seconds or more to start the test run.

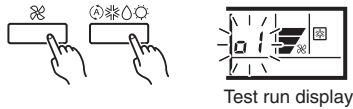

- (3) Press the start/stop button to stop the test run.

[SELF-DIAGNOSIS]

When the error indication "E:EE" is displayed, follow the following items to perform the self-diagnosis. "E:EE" indicates an error has occurred.

1. REMOTE CONTROLLER DISPLAY

- (1) Stop the air conditioner operation.
- (2) Press the set temperature buttons Δ / ∇ simultaneously for 5 seconds or more to start the self-diagnosis.
Refer to the following tables for the description of each error code.

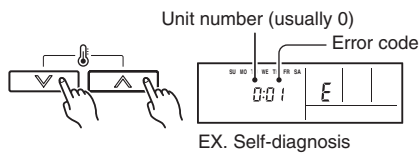

- (3) Press the set temperature buttons Δ / ∇ simultaneously for 5 seconds or more to stop the self-diagnosis.

Error code	Error contents
00	Communication error (indoor unit ↔ remote controller)
01	Communication error (indoor unit ↔ outdoor unit)
02	Room temperature sensor open
03	Room temperature sensor short-circuited
04	Indoor heat exchanger temperature sensor open
05	Indoor heat exchanger temperature sensor short-circuited
06	Outdoor heat exchanger temperature sensor open
07	Outdoor heat exchanger temperature sensor short-circuited
08	Power source connection error
09	Float switch operated
0A	Outdoor temperature sensor open
0b	Outdoor temperature sensor short-circuited
0c	Discharge pipe temperature sensor or compressor temperature sensor open
0d	Discharge pipe temperature sensor or compressor temperature sensor short-circuited
0E	Outdoor high pressure abnormal
0F	Discharge pipe temperature or compressor temperature abnormal
11	Model abnormal
12	Indoor fan abnormal
13	Outdoor signal abnormal
14	Outdoor EEPROM abnormal

2. OUTDOOR UNIT LEDS

Heat & Cool model (reverse cycle) only

When a malfunction occurs in the outdoor unit, the LEDs on the circuit board light to indicate the error. Refer to the following table for the description of each error according to the LEDs.

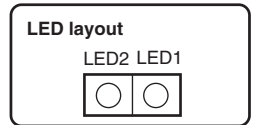

LED1	LED2	Error contents
flash	flash	Model abnormal or EEPROM abnormal
1 flash	Lighting	Power source connection error
2 flash	Lighting	Discharge temp. sensor error
3 flash	Lighting	Heat exchanger temp. sensor error
4 flash	Lighting	Outdoor temp. sensor error
5 flash	Lighting	Communication signal error
6 flash	Lighting	Indoor unit error
7 flash	Lighting	Discharge temp. abnormal
8 flash	Lighting	High pressure abnormal
9 flash	Lighting	Compressor temp. abnormal
10 flash	Lighting	Compressor temp. sensor error
Dislighting		No error. Protect operation

When the fault is cleared, the LED lamp goes off.

However, for discharge pipe temperature abnormal and high pressure abnormal, the LED lamp lights continuously for 24 hours, as long as the power is not turned off.

DISASSEMBLY ILLUSTRATION

Model : ARY36UUAN

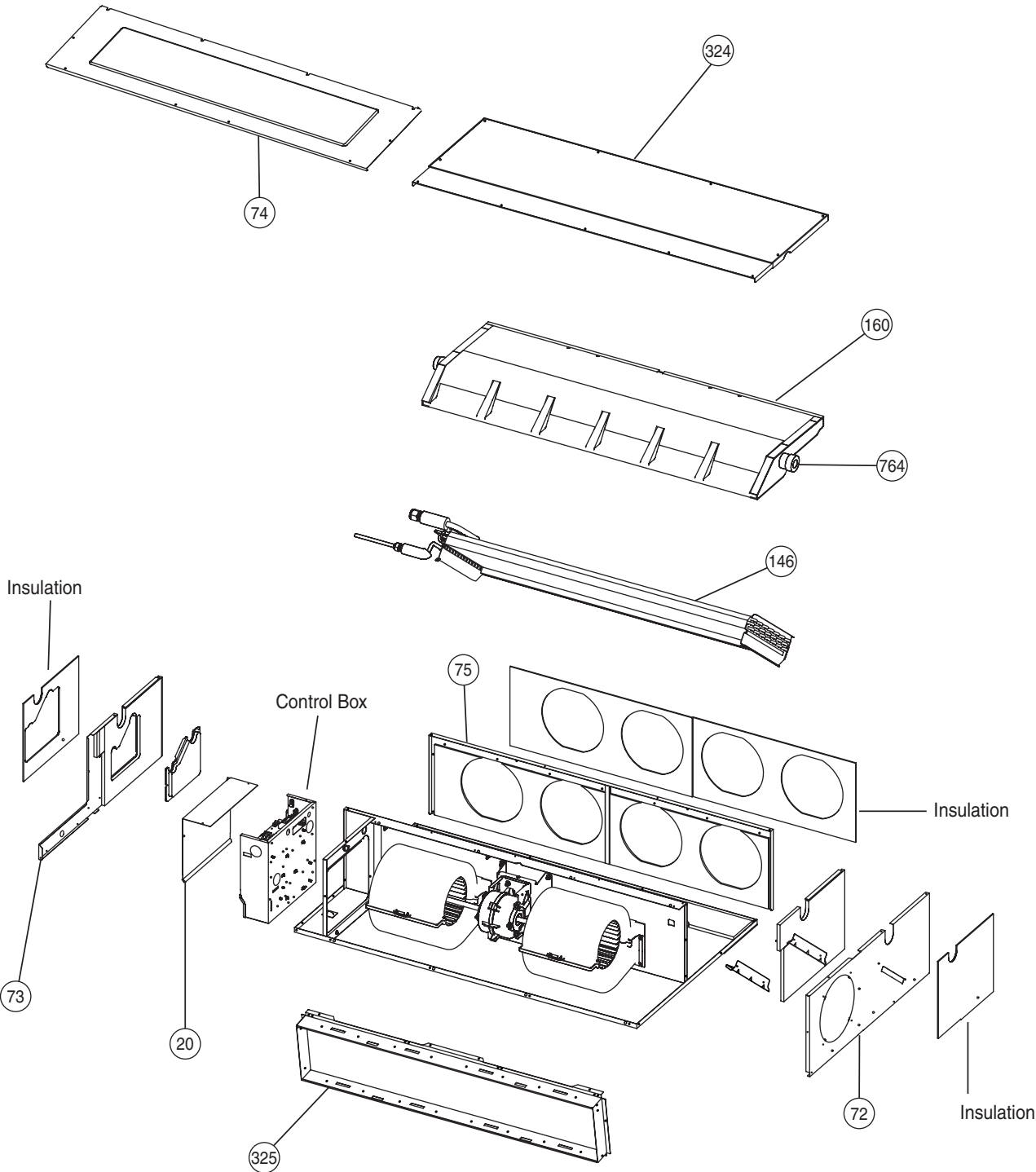

Model : ARY36UUAN

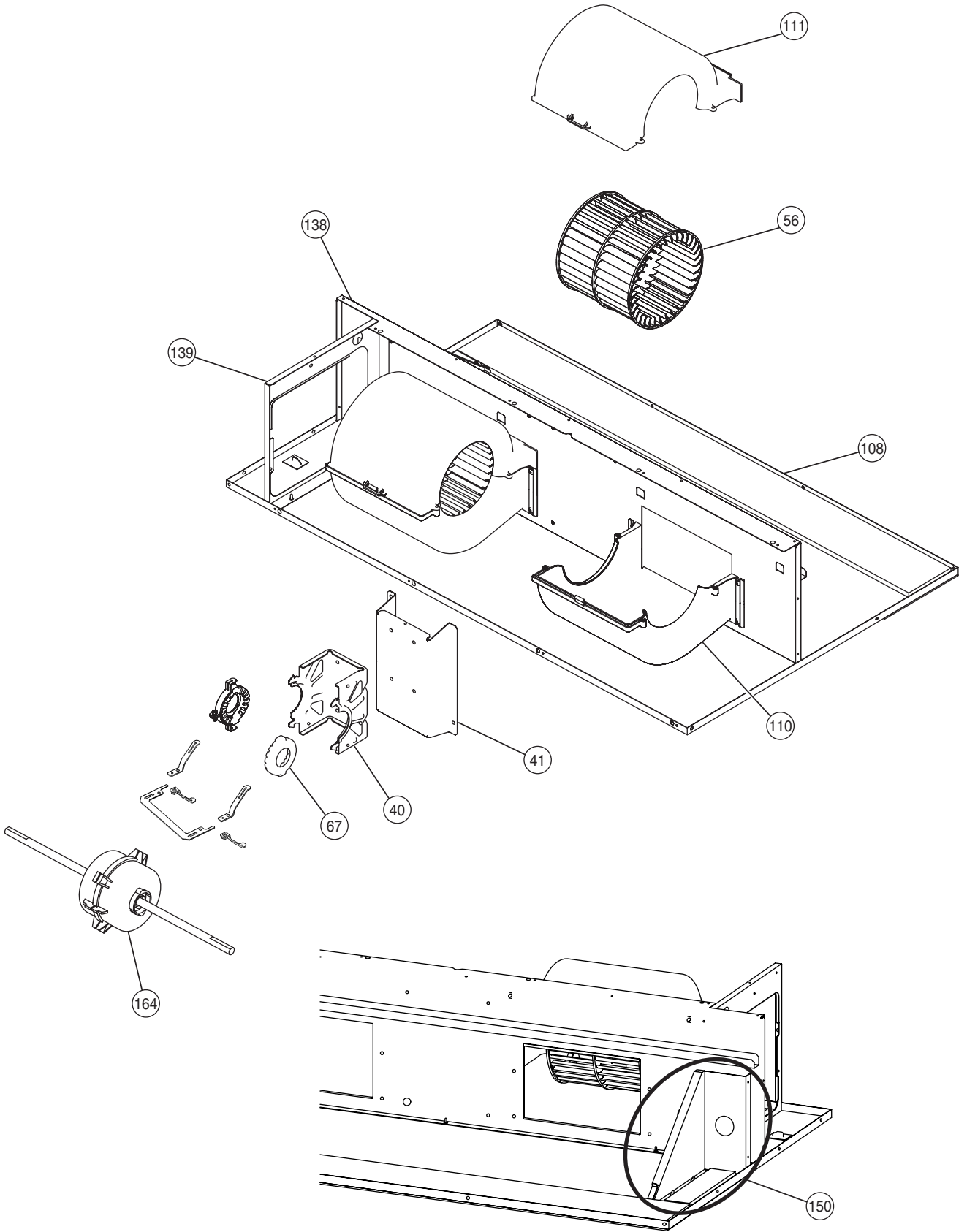

Model : ARY36UUAN

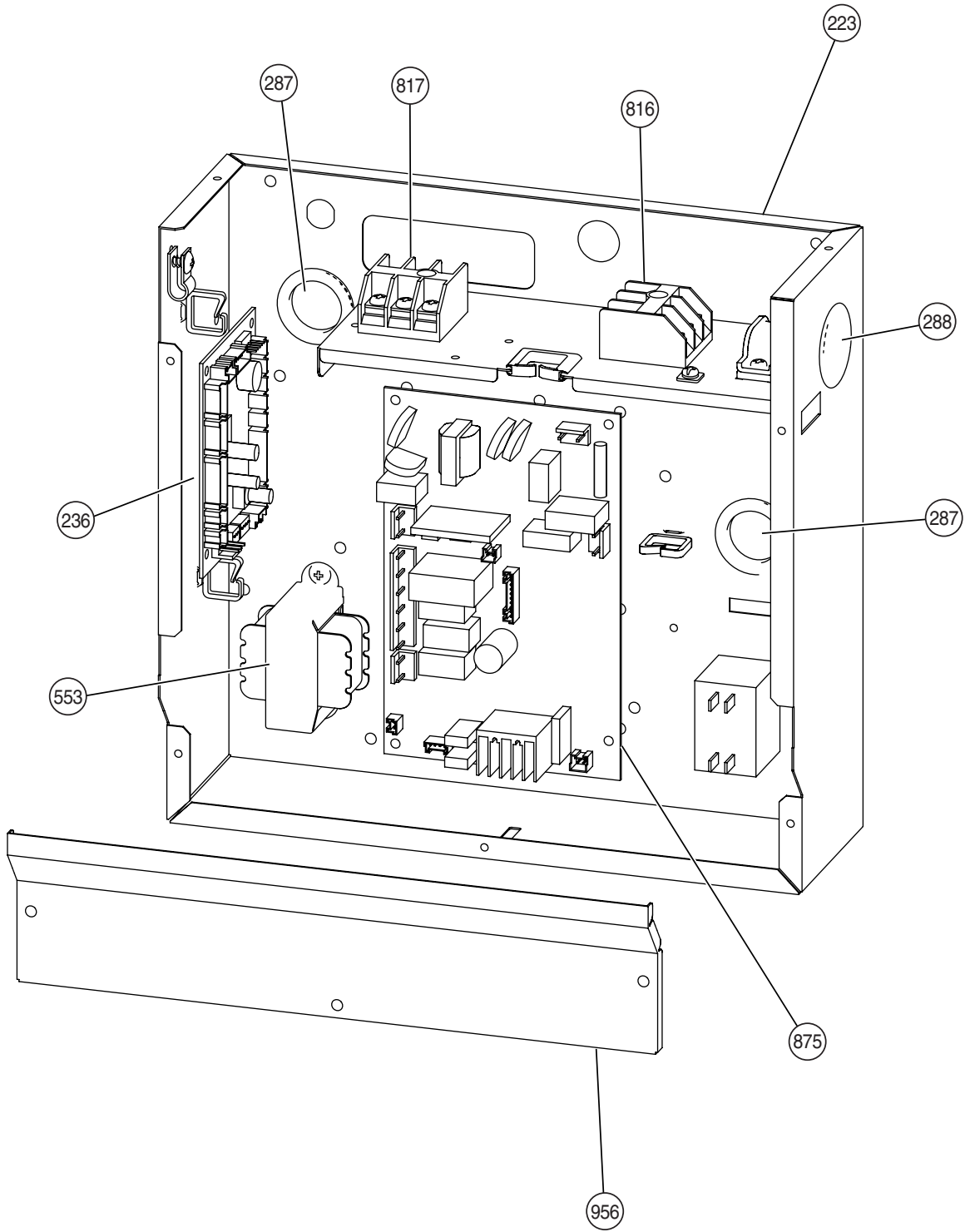

Model : AOY36UMAXL

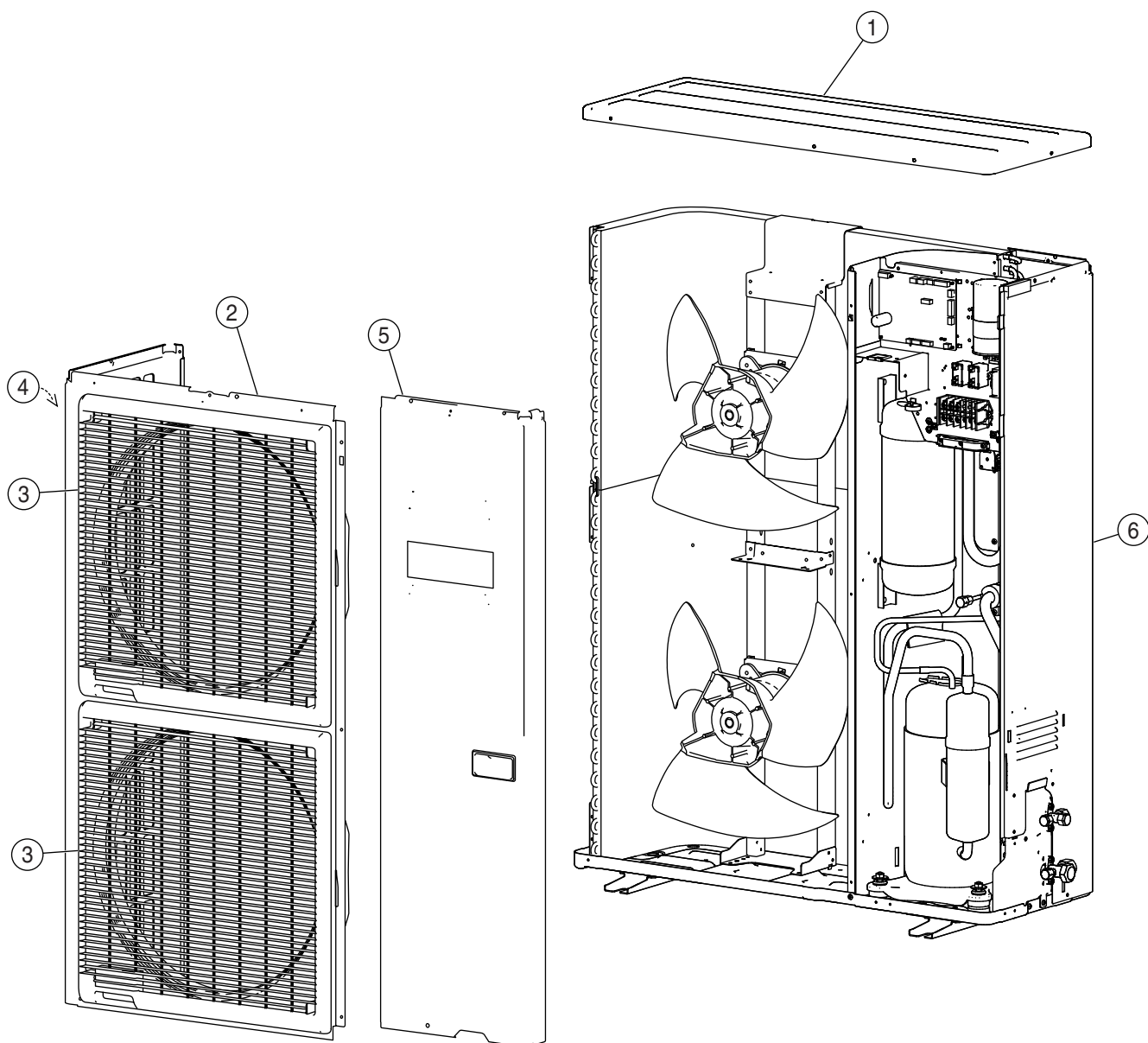

Model : AOY36UMAXL

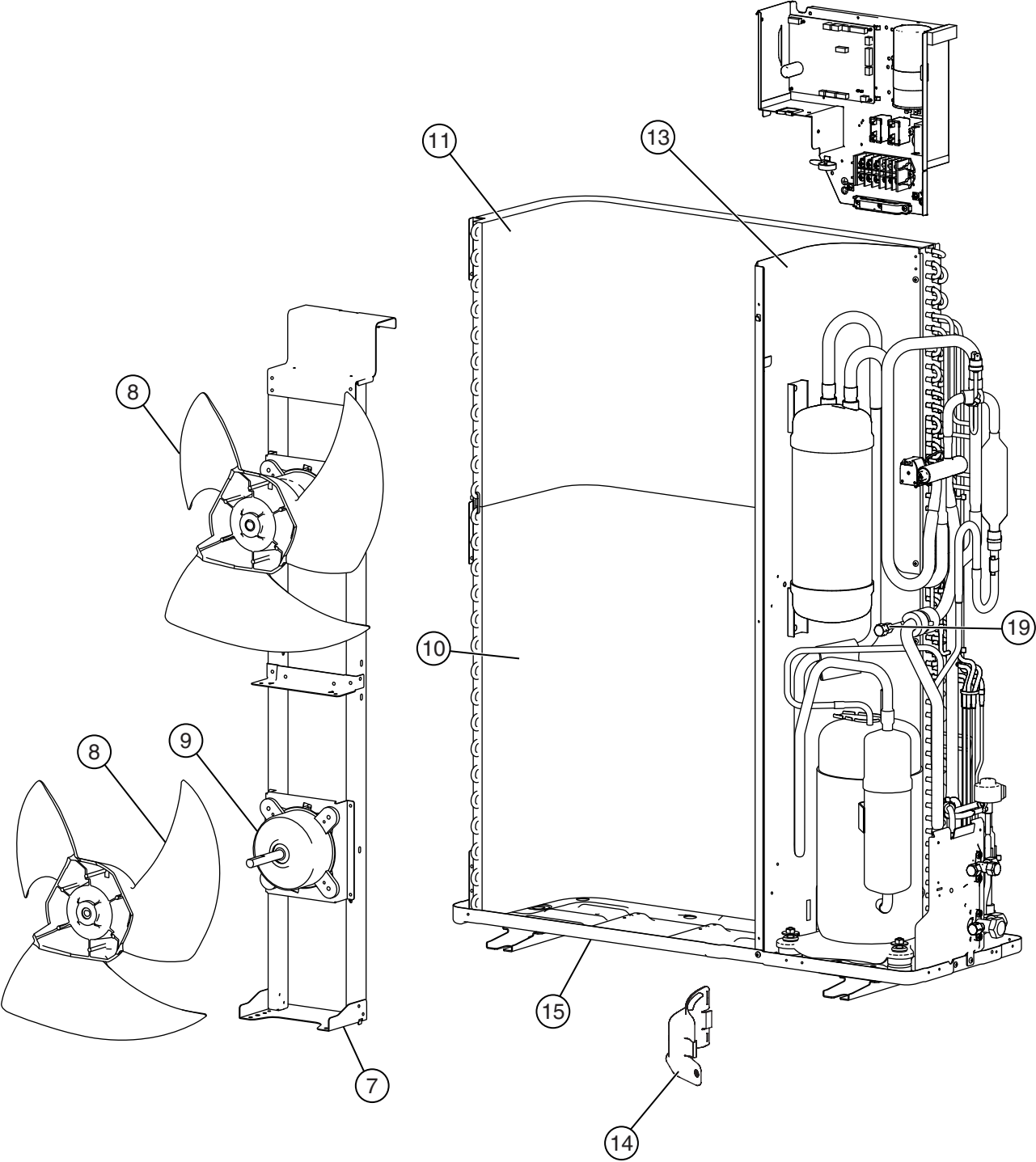

Model : AOY36UMAXL

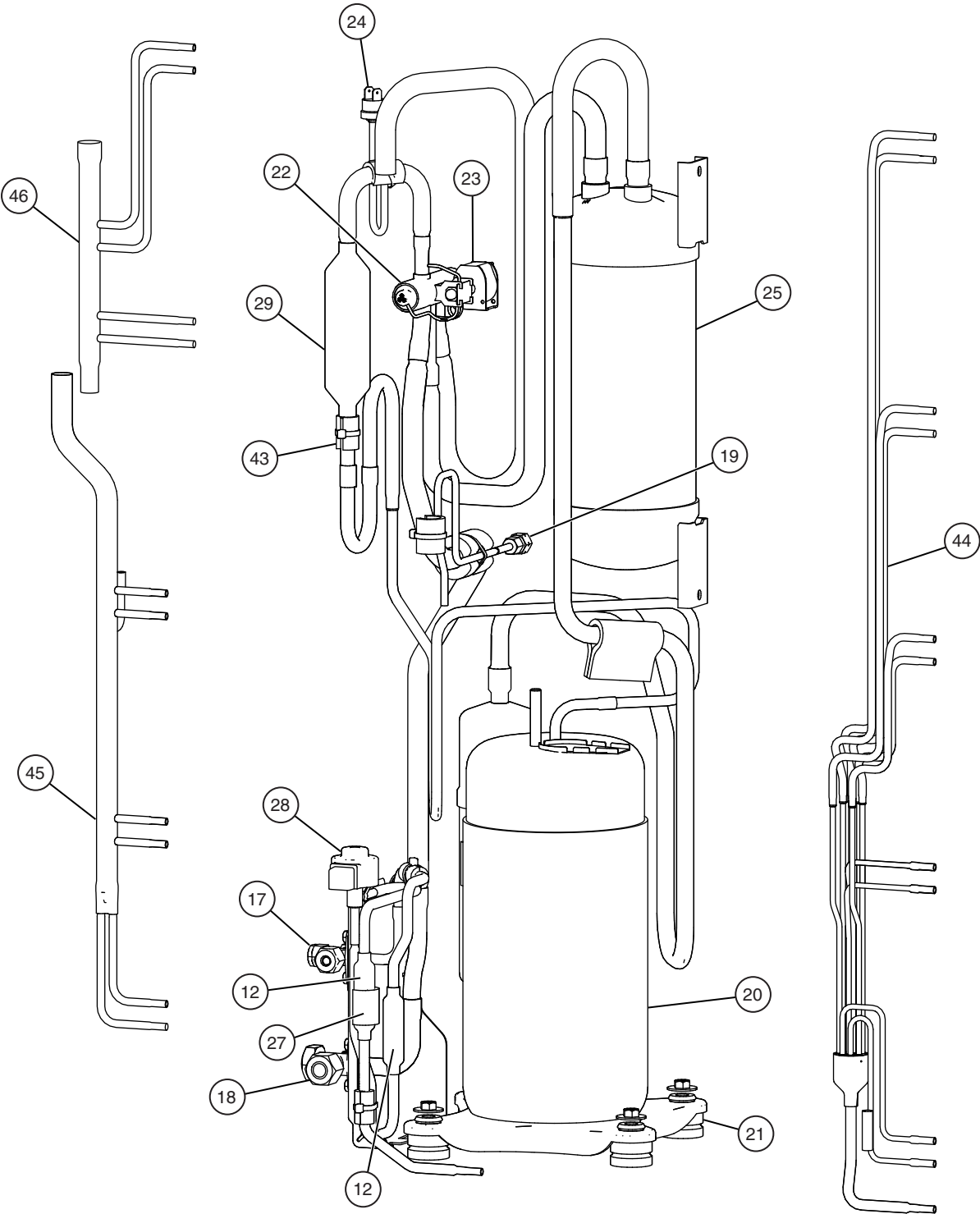

Model : AOY36UMAXL

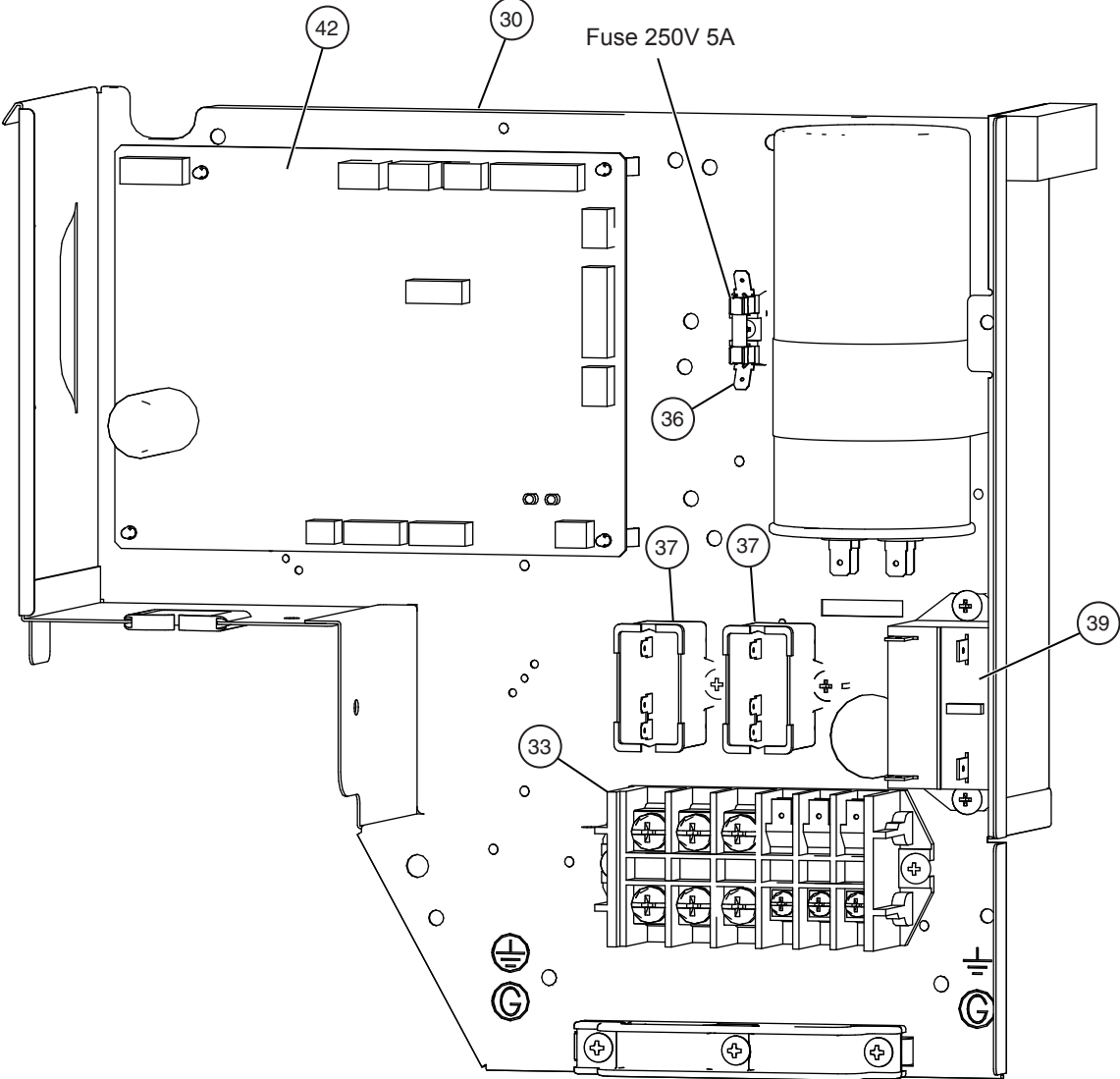

PARTS LIST

INDOOR UNIT

Ref. No.	Description	Part No.	Ord.
		ARY36JUAN	Q'ty
20	Control Cover-A Sub Assy	9374516018	
40	Motor Mount	9374281015	
41	Bracket Motor Assy	9374230013	
56	Sirocco Fan Assy	9356531022	
67	Rubber	313659068604	
72	Cabinet-L Sub Assy	9374509010	
73	Cabinet-R Sub Assy	9374508013	
74	Intake Cover Sub Assy	9374512010	
75	Outlet Panel Sub Assy	9374510016	
108	Base Sub Assy	9374504015	
110	Casing-A	9374233014	
111	Casing-B	9374234011	
138	Separate Wall Assy	9374228010	
139	Panel (Control Box) Sub Assy	9374506019	
146	Evaporator Assy	9374518012	
150	Bracket (Eva.)-R	9374207015	
160	Drain Pan Sub Assy	9374513017	
164	Motor, Induction	9600830093	
223	Control Box-A	9374219018	
236	Controller PCB Assy	9705246096	
287	Cap (Power)	9352173011	
288	One Touch Bush	9374407019	
324	Main Panel Sub Assy	9374511013	
325	Intake Frame Assy	9374216017	
553	Transformer (Power)	9704129017	
764	Drain Cap	9356541007	
816	Terminal-3P	9703345012	
817	Terminal-3P	9306489045	
875	Power Supply PCB Assy	9705668010	
956	Control Cover -B	9374222018	
----	Thermistor Spring-A	313728262708	
----	Room Temperature Thermistor	9703299025	
----	Pipe Temperature Thermistor	9703297021	
----	Remote Control Unit Assy	9372266014	
----	RFM (Motor Band)	9374646012	
----	Control Box-B	9374220014	
----	Motor Band-A Assy	9374647019	
----	Wire w/Connector	9704856012	
----	Wire w/Connector	9705245020	
----	Wire w/Connector	9705243026	
----	Wire w/Connector	9705244023	
----	Capacitor Plastic (For Fan Motor)	9900269173	

When you order parts, please make a photocopy of this page and fill the number of the parts in the "Order" column.



OUTDOOR UNIT



Ref. No.	Description	Part No.	Ord. Q'ty
		AOY36UMAXL	
1	Top Panel Sub Assy	9374417018	
2	Front Panel	9374094042	
3	Fan Guard	9374330010	
4	Side Grip	9374173013	
5	Service Panel Sub Assy	9374415021	
6	Right Panel Sub Assy	9374416028	
7	Motor Bracket Sub Assy	9374418022	
8	Propeller Fan Assy	9366378013	
9	Motor, Induction	9601671060	
10	Condenser-A Assy	9374433032	
11	Condenser-B Assy	9374434039	
12	Strainer Assy	9372524015	
13	Separate Wall	9374135028	
14	Cap Foot	9374345014	
15	Base Assy	9374166022	
17	3-Way Valve Assy (3/8)	9372205044	
18	3-Way Valve Assy (5/8)	9372205075	
19	Check Joint Assy	9372802038	
20	Compressor Assy	9374250028	
21	Rubber Mount	9362368001	
22	4-Way Valve	9900164010	
23	Solenoid	9900165055	
24	Pressure Switch	9900186012	
25	Accumulator Assy	9371615011	
27	Capillary Holder Rubber	313394274808	
28	Expansion Valve Assy	9370947090	
29	Muffler	9372369036	
30	Control Box	9374164011	
33	Terminal HP-T3041-C3B3-L0	9900184018	
36	Fuse Holder	0501456016	
37	Capacitor, Plastic (for Fan Motor)	9900270049	
39	Relay	9900074012	
42	Controller PCB Assy	9705677043	
43	Thermistor Spring	9372140017	
44	Outlet Pipe (Cond) A Assy	9974266029	
45	Inlet Pipe (Cond) A Assy	9373461036	
46	Inlet Pipe (Cond) B Assy	9373463030	
----	Belt Heater	9361140264	
----	Thermistor Assy	9900274016	
----	Fuse 6.3A-250V	0600222574	
----	Fuse Holder	0500158072	
----	Protective Net-L	9374255023	
----	Drain Pipe (I-Yipe)	9301102000	
----	Drain Packing	9301143003	
----	Drain Cap	313166024302	
----	Emblem Rear	9351355005	
----	Wire w/Connector Assy (Fan)	9374398058	
----	Wire w/Connector-B Assy (Fan)	9374398027	
----	Wire w/Conector-A Assy (Heater)	9374399017	
----	Wire w/Terminal Assy (comp.)	9374395057	
----	Wire w/Connector Assy (Relay)	9374397020	
----	Wire w/Connector (Power)	9374396030	
----	Expansion Valve Coil	9900190026	
----	Terminal Cover (Comp.)	9362369008	
----	Terminal Gasket (Comp.)	9362370004	
----	Valve Cover	9374174010	
----	Compressor Cover-A	9374430062	
----	Compressor Cover-B	9374431069	

When you order parts, please make a photocopy of this page and fill the number of the parts in the "Order" column.

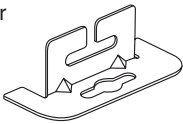

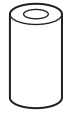
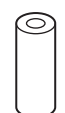
STANDARD ACCESSORIES

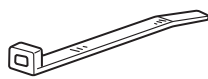
INDOOR UNIT ACCESSORIES

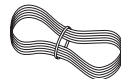
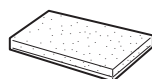
Name and Shape	Q'ty	Application
Hanger 	4	For suspending the indoor unit from ceiling
Special nut A (large flange) 	4	For suspending the indoor unit from ceiling
Special nut B (small flange) 	4	
Coupler heat insulation (large) 	1	For indoor side pipe joint (gas pipe)
Coupler heat insulation (small) 	1	For indoor side pipe joint (liquid pipe)

Name and Shape	Q'ty	Application
Binder 	1 (large)	For fixing the drain hose
	1 (small)	For fixing the remote controller cord
Remote controller 	1	
Tapping screw (flush heads) 	2	For installing the remote controller
Remote controller cord 	1	For connecting the remote controller
Drain hose insulation 	1	Insulates the drain hose and vinyl hose

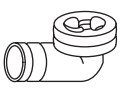
OUTDOOR UNIT ACCESSORIES

Drain pipe 	1	For outdoor unit drain piping work [Heat & Cool model (Reverse cycle) only]
Drain cap 	2	

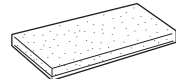
Insulation (seal) 	1	For filling in a gap at the entrance of connection cords
---	---	--

OPTIONAL PARTS

When connecting the square duct and round duct, use the optional square flange or round flange.

Square flange

Model name : UTD-SF045T (P/N 9098180007)
40 mm

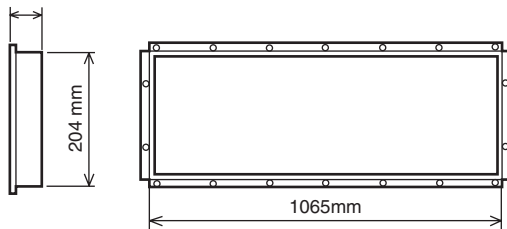

Round flange

Model name : UTD-RF204 (P/N 9093160004)

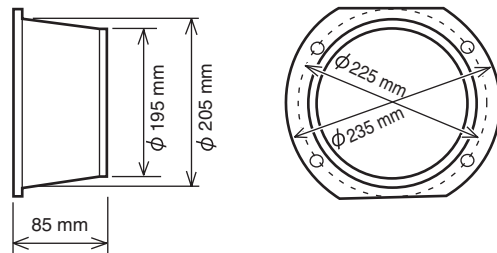

Long-life filter

Model name : UTD-LF25NA (P/N9079892004)

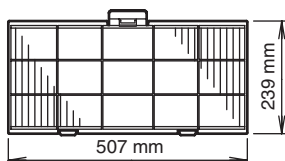

Remote sensor

Model name : UTD-RS100 (P/N9072619004)

External control wire set

Model name : UTD-ECS5A (P/N9077359004)

0512G2957