

SERVICE MANUAL



Indoor unit	Outdoor unit
RGF09LAC	} ROM-30LA4
RGF12LAC	
RGF14LAC	

CONTENTS

SPECIFICATIONS.....	1
OUTLINE AND DIMENSIONS.....	3
REFRIGERANT SYSTEM DIAGRAM ...	5
CIRCUIT DIAGRAM.....	6
PCB CIRCUIT DIAGRAM.....	8
ERROR DISPLAY.....	14
PARTS (INDOOR UNIT).....	16
PARTS (OUTDOOR UNIT).....	21
ACCESSORIES.....	26

SPECIFICATIONS

INDOOR UNIT

ELECTRICAL DATA

TYPE		Cooling & heating inverter		
MODEL NAME		RGF09LAC	RGF12LAC	RGF14LAC
MOISTURE REMOVAL		0.7 L/hr	1.1 L/hr	1.5 L/hr
AIR CIRCULATION HIGH	Cooling	530 m3/hr	600 m3/hr	650 m3/hr
	Heating	530 m3/hr	600 m3/hr	650 m3/hr

FAN MOTOR

POWER SOURCE		230 V	230 V	230 V
Cooling (upper fan / lower fan)	High speed	1,120 / 950 r.p.m.	1,240 / 1,050 r.p.m.	1,330 / 1,120 r.p.m.
	Med speed	960 / 820 r.p.m.	1,050 / 890 r.p.m.	1,100 / 930 r.p.m.
	Low speed	820 / 700 r.p.m.	860 / 730 r.p.m.	890 / 750 r.p.m.
	Quiet	660 / 560 r.p.m.	660 / 560 r.p.m.	660 / 560 r.p.m.
Heating (upper fan / lower fan)	High speed	1,120 / 950 r.p.m.	1,240 / 1,050 r.p.m.	1,330 / 1,120 r.p.m.
	Med speed	1,000 / 850 r.p.m.	1,080 / 920 r.p.m.	1,140 / 970 r.p.m.
	Low speed	860 / 730 r.p.m.	910 / 770 r.p.m.	940 / 800 r.p.m.
	Quiet	660 / 560 r.p.m.	660 / 560 r.p.m.	660 / 560 r.p.m.

NOISE LEVEL

Cooling / Heating	High speed	39 dB(A) / 39 dB(A)	42 dB(A) / 42 dB(A)	44 dB(A) / 44 dB(A)
	Med speed	34 dB(A) / 35 dB(A)	36 dB(A) / 38 dB(A)	38 dB(A) / 39 dB(A)
	Low speed	28 dB(A) / 30 dB(A)	30 dB(A) / 32 dB(A)	31 dB(A) / 33 dB(A)
	Quiet	22 dB(A) / 22 dB(A)	22 dB(A) / 22 dB(A)	22 dB(A) / 22 dB(A)

MEASUREMENT

DIMENSIONS	H x W x D	600 x 740 x 200 mm
WEIGHT	Gross / Net	17 kg / 14 kg

OUTDOOR UNIT

ELECTRICAL SPECIFICATIONS

TYPE		Cooling & heating multi
MODEL NAME		ROM-30LA4
COOLING CAPACITY		8.0 kW
HEATING CAPACITY		9.6 kW
POWER SUPPLY		(220) - 230 - (240) V
FREQUENCY		50 Hz
RUNNING CURRENT	Cooling	9.7 A
	Heating	10.5 A
INPUT	Cooling	2.22 kW
	Heating	2.40 kW
EER	Cooling	3.60 kW/kW
	Heating	4.00 kW/kW
AIR CIRCULATION HIGH		3,300 m ³ /hr

FAN MOTOR

DISCRIMINATION	MFE-60PO
HIGH SPEED (Cooling)	820 r.p.m.
HIGH SPEED (Heating)	780 r.p.m.

MEASUREMENT

DIMENSIONS	H x W x D	830 x 900 x 330 mm
WEIGHT	Gross / Net	78 kg / 68 kg

COMPRESSOR AND REFRIGERANT

TYPE		Hermetic type, Inverter, 4 poles, 3-phase, DC motor, Twin Rotary
DISCRIMINATION		TNB220FPBMT
WEIGHT (with oil)		14.3 kg
STANDARD REFRIGERANT		3,300 g
REFRIGERANT TYPE		R410A
FULL CHARGE	Total Pipe Length 50 m	3,300 g
	60 m	3,550 g
	70 m	3,800 g
ADDITIONAL CHARGE		25 g/m
CHARGELESS		50 m
MAX PIPE LENGTH (each unit)		25 m
MAX PIPE LENGTH (total)		70 m
MAX ELEVATION (between indoor units)		10 m
MAX ELEVATION (between indoor and outdoor)		10 m
MIN. PIPE LENGTH (each unit)		5 m

DIMENSIONS

INDOOR UNIT

(unit : mm)

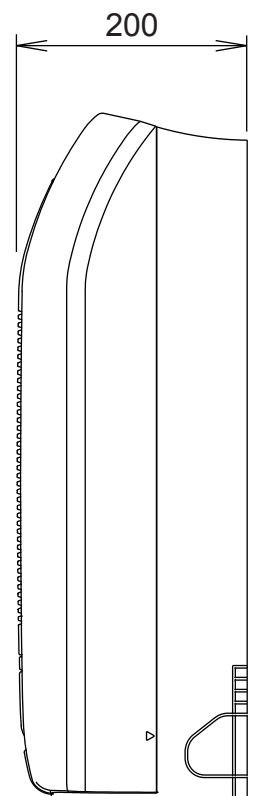
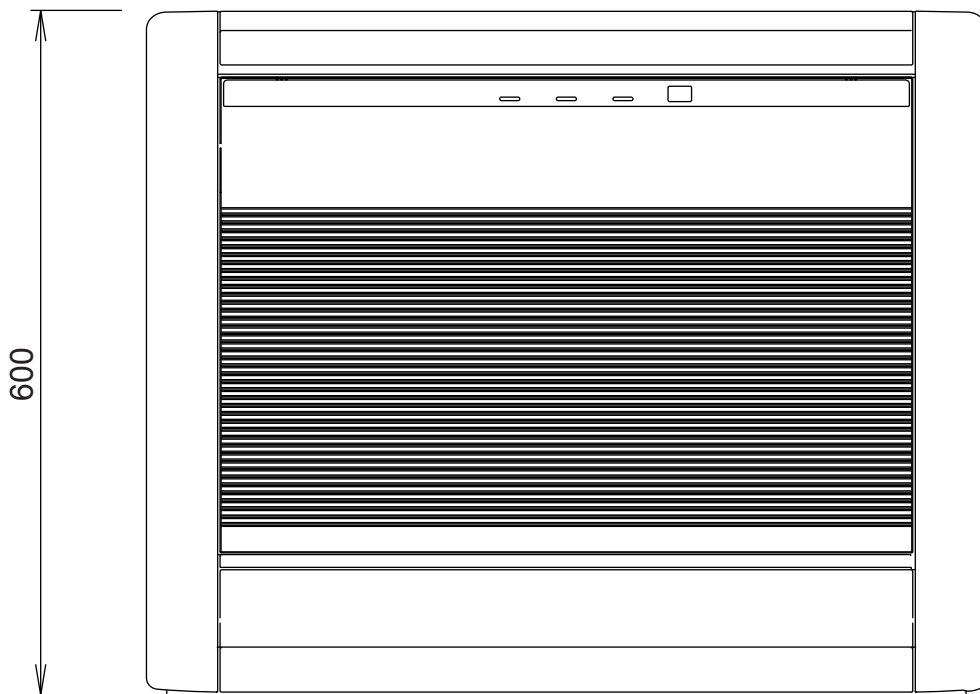
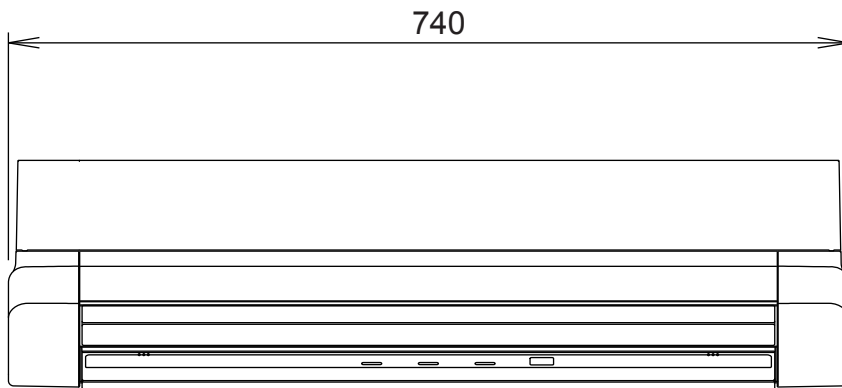

OUTDOOR UNIT

(Unit : mm)

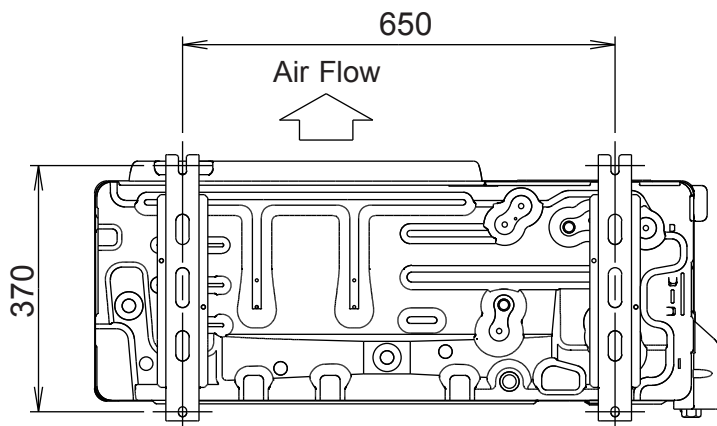
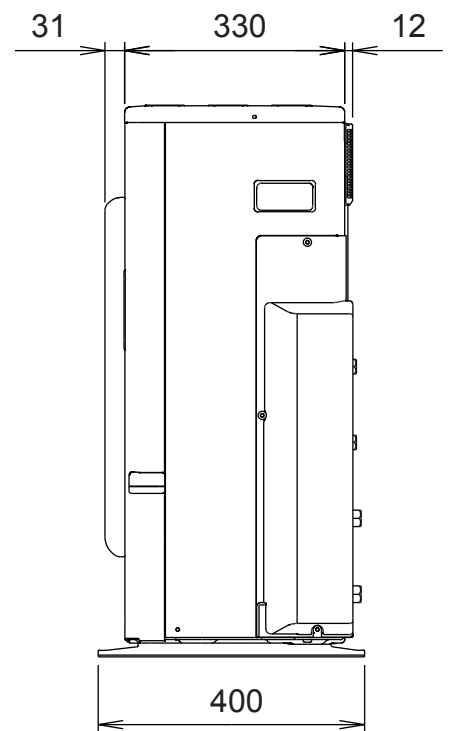
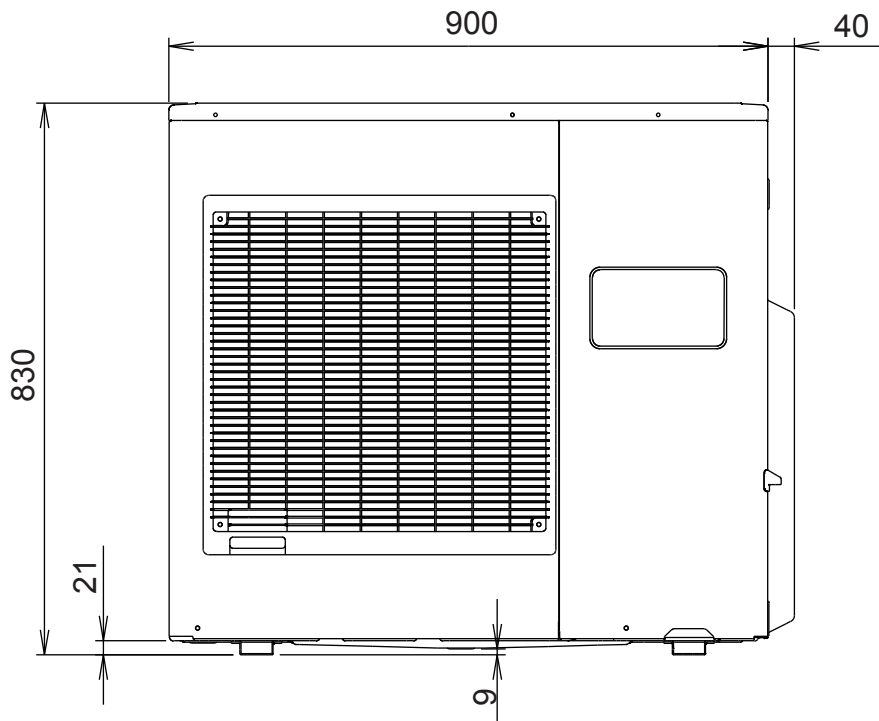
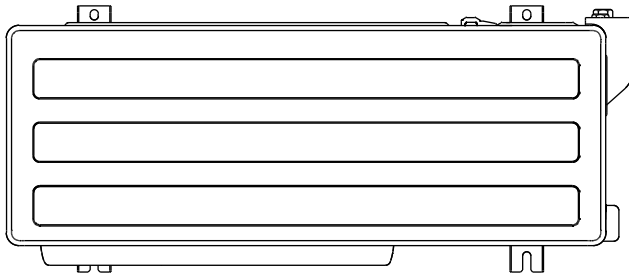

REFRIGERANT SYSTEM DIAGRAM

OUTDOOR UNIT

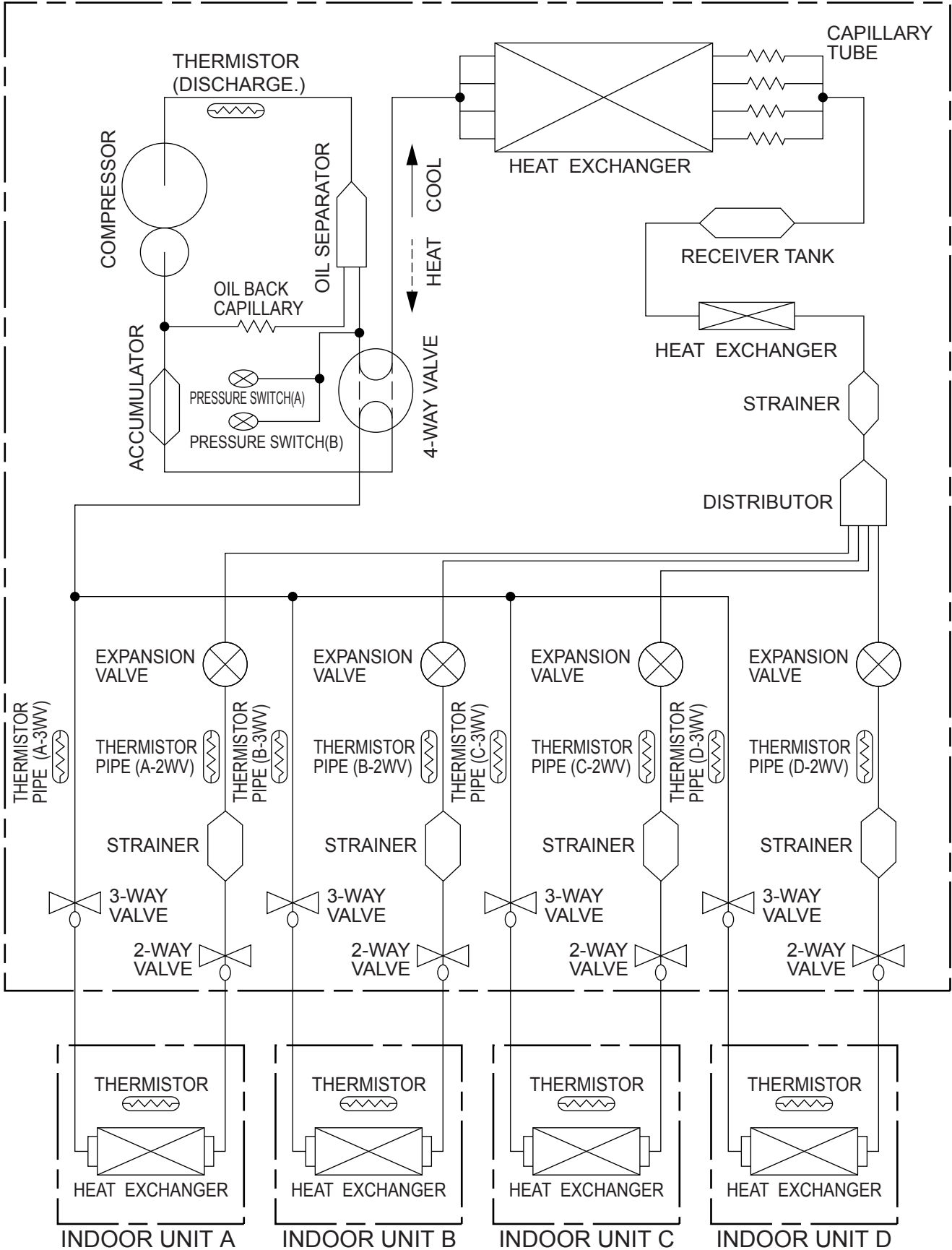

CIRCUIT DIAGRAM

INDOOR UNIT

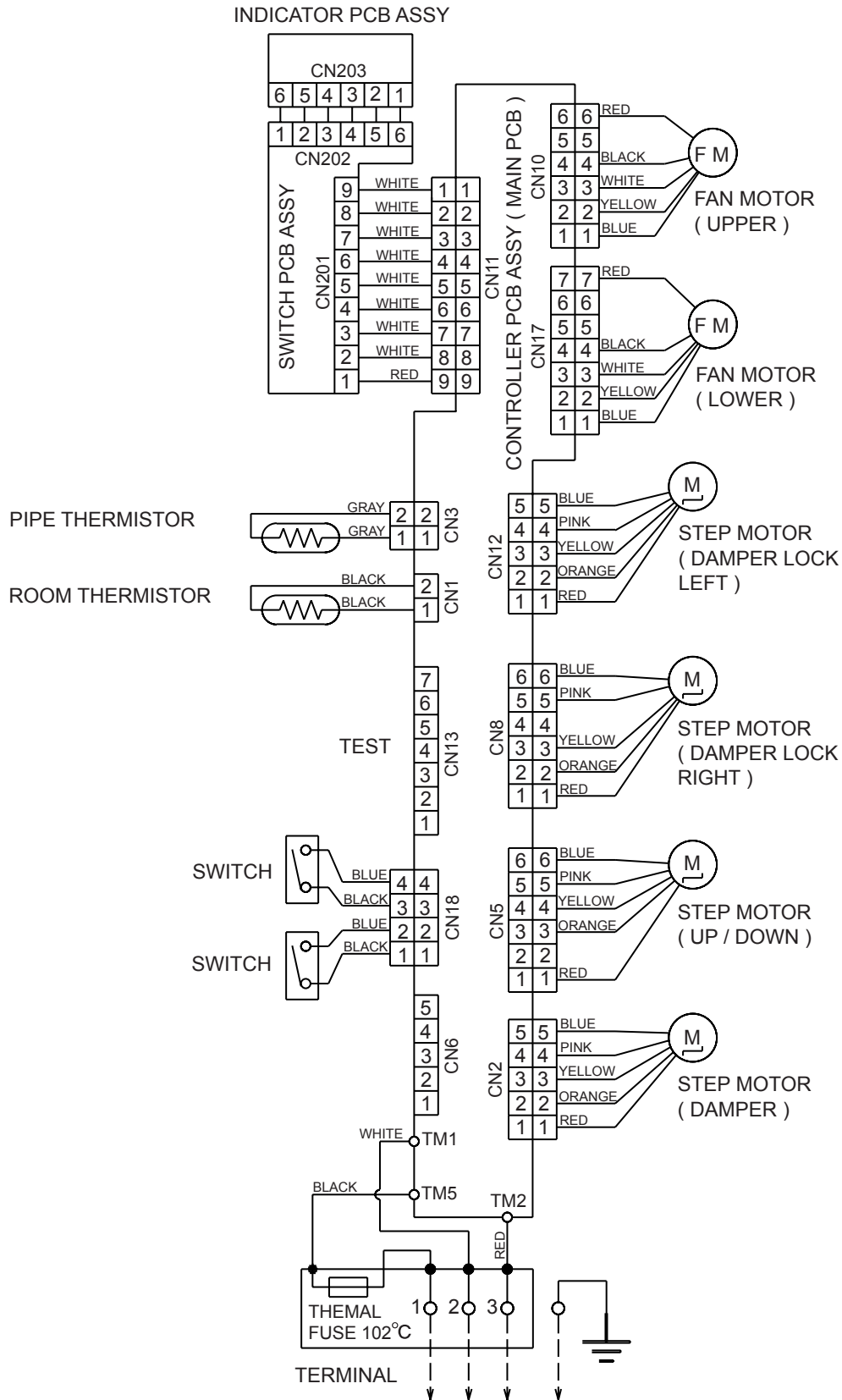

OUTDOOR UNIT

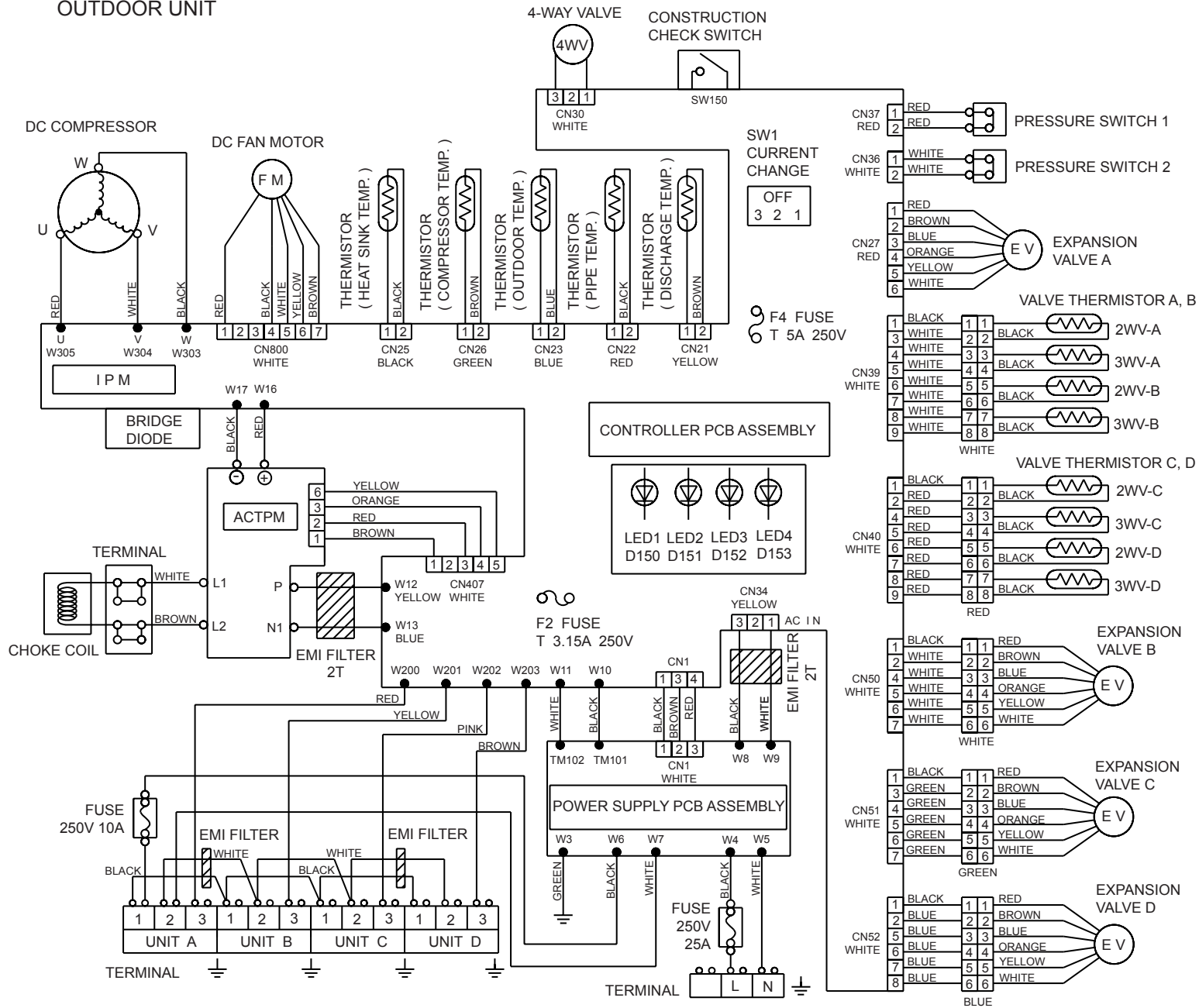

INDOOR PCB CIRCUIT DIAGRAM

CONTROL UNIT

RGF09LAC : EZ-0070CHSE

RGF12LAC : EZ-0070DHSE

RGF14LAC : EZ-0070EHSE

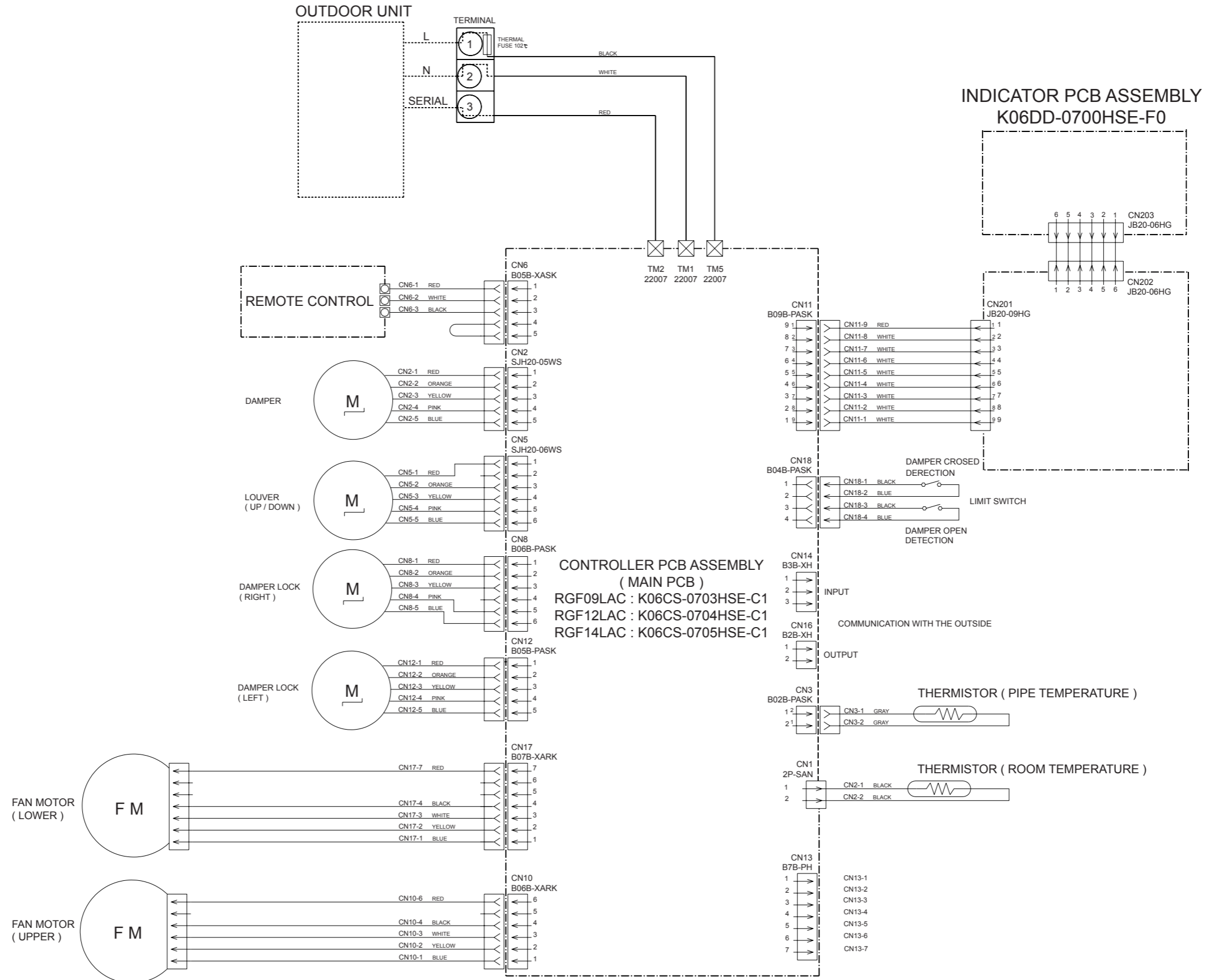

INDOOR UNIT
 CONTROLLER PCB ASSEMBLY (MAIN PCB)
 RGF09LAC : K06CS-0703HSE-C1
 RGF12LAC : K06CS-0704HSE-C1
 RGF14LAC : K06CS-0705HSE-C1

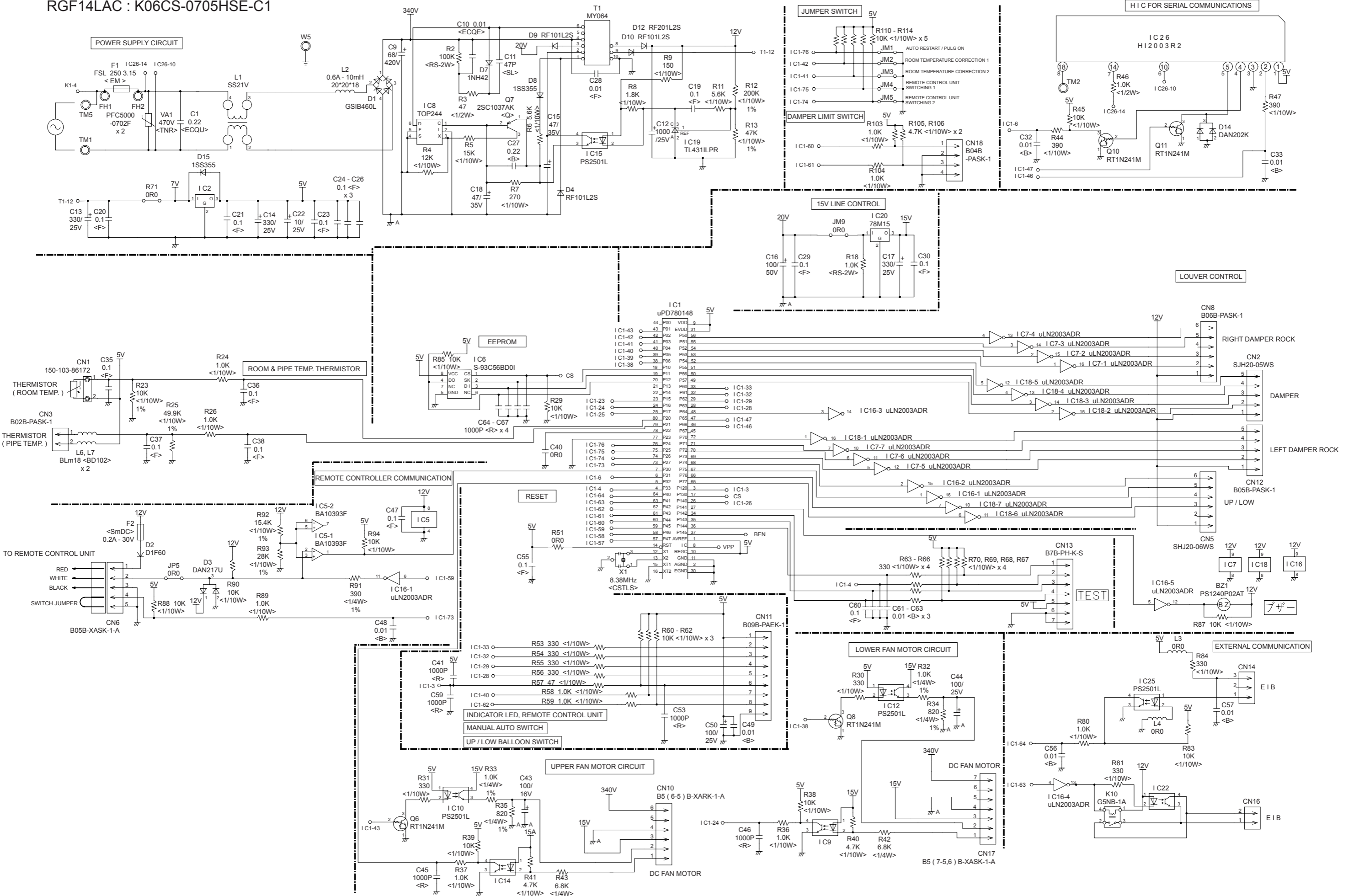

INDOOR UNIT
 INDICATOR PCB ASSEMBLY
 K06DD-0700HSE-F0

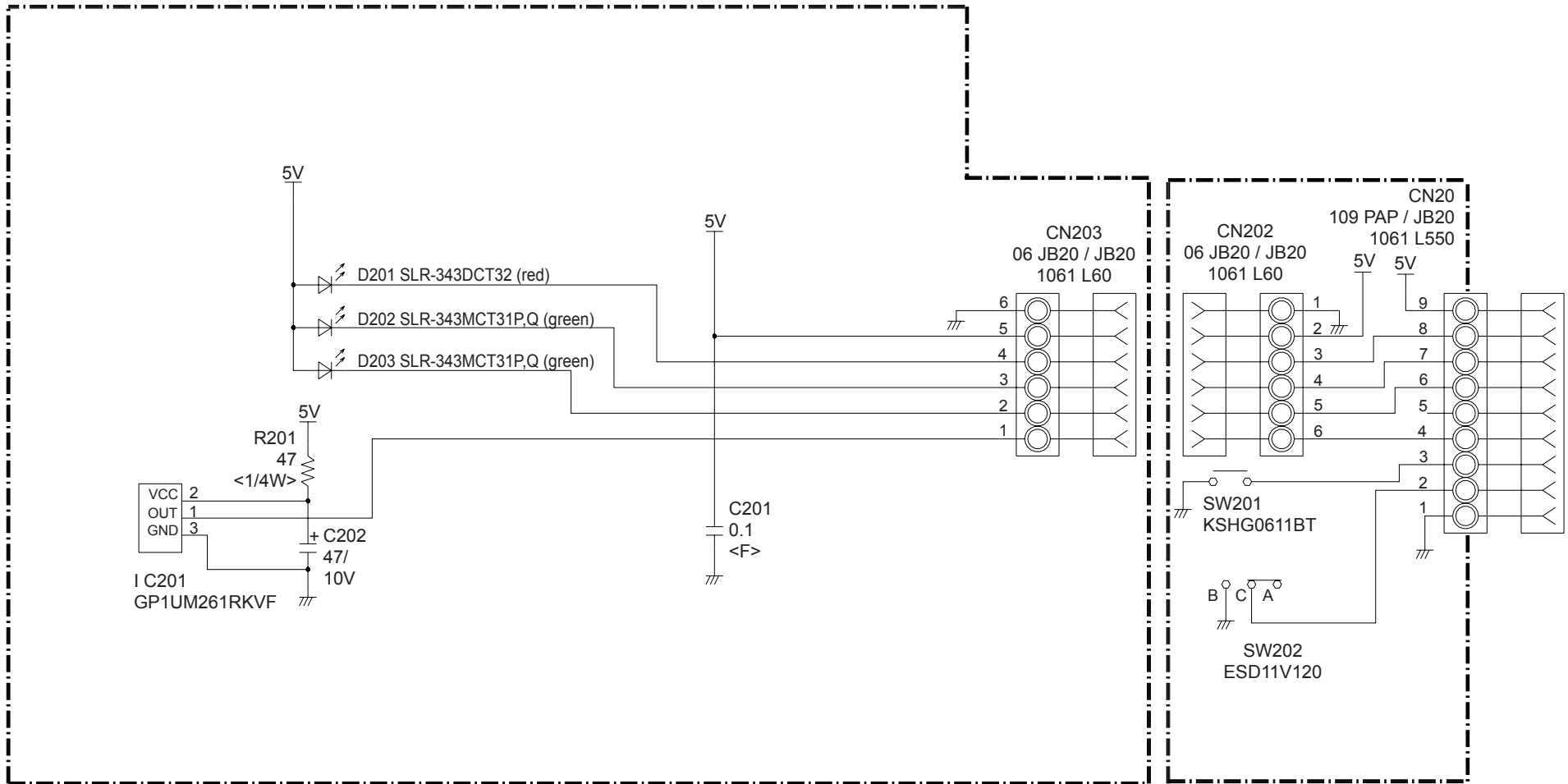

OUTDOOR PCB CIRCUIT DIAGRAM

INVERTER ASSEMBLY EZ-004HHUE

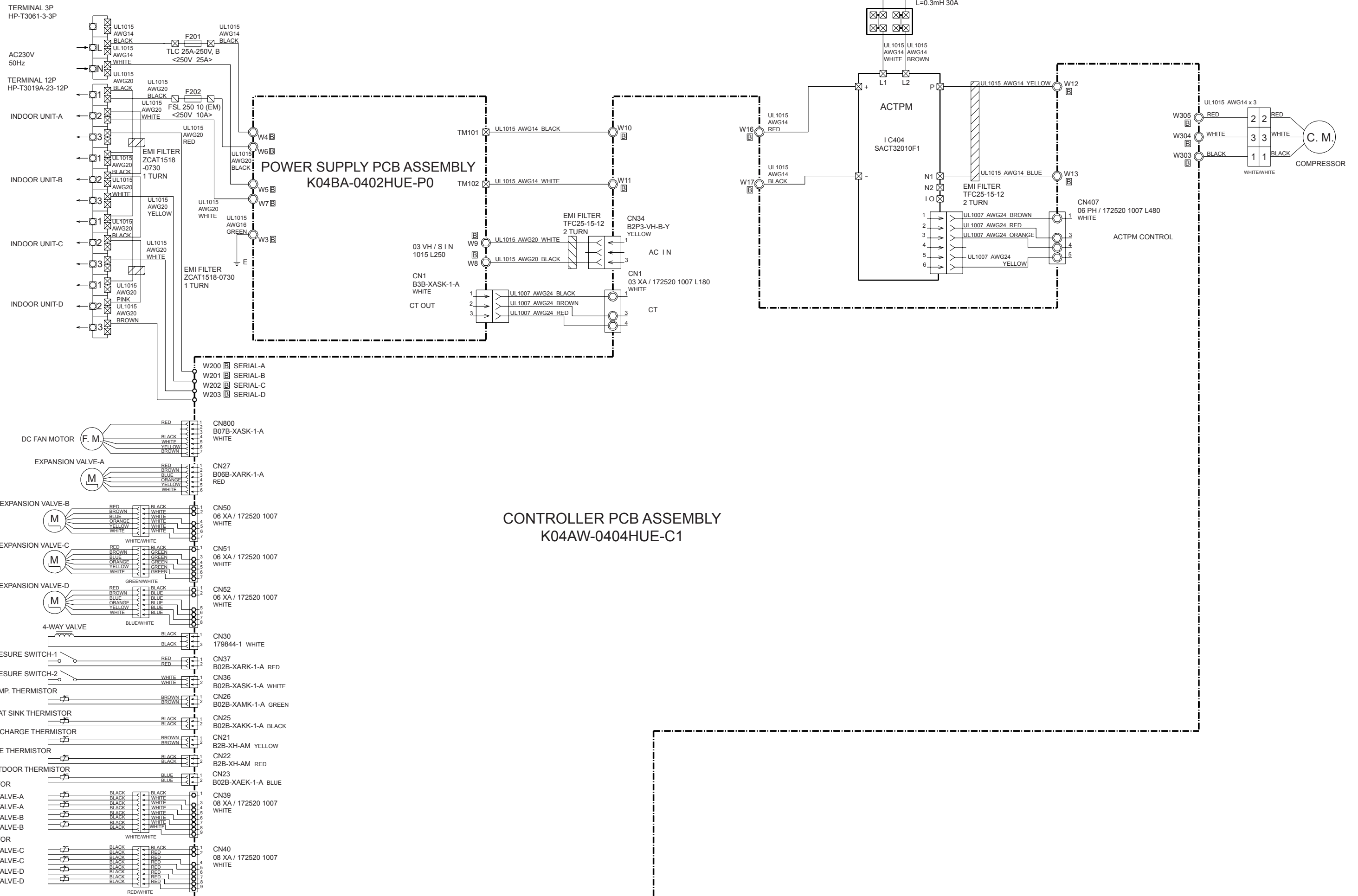

OUTDOOR UNIT
 CONTROLLER PCB ASSEMBLY (MAIN PCB)
 K04AW-0404HUE-C1

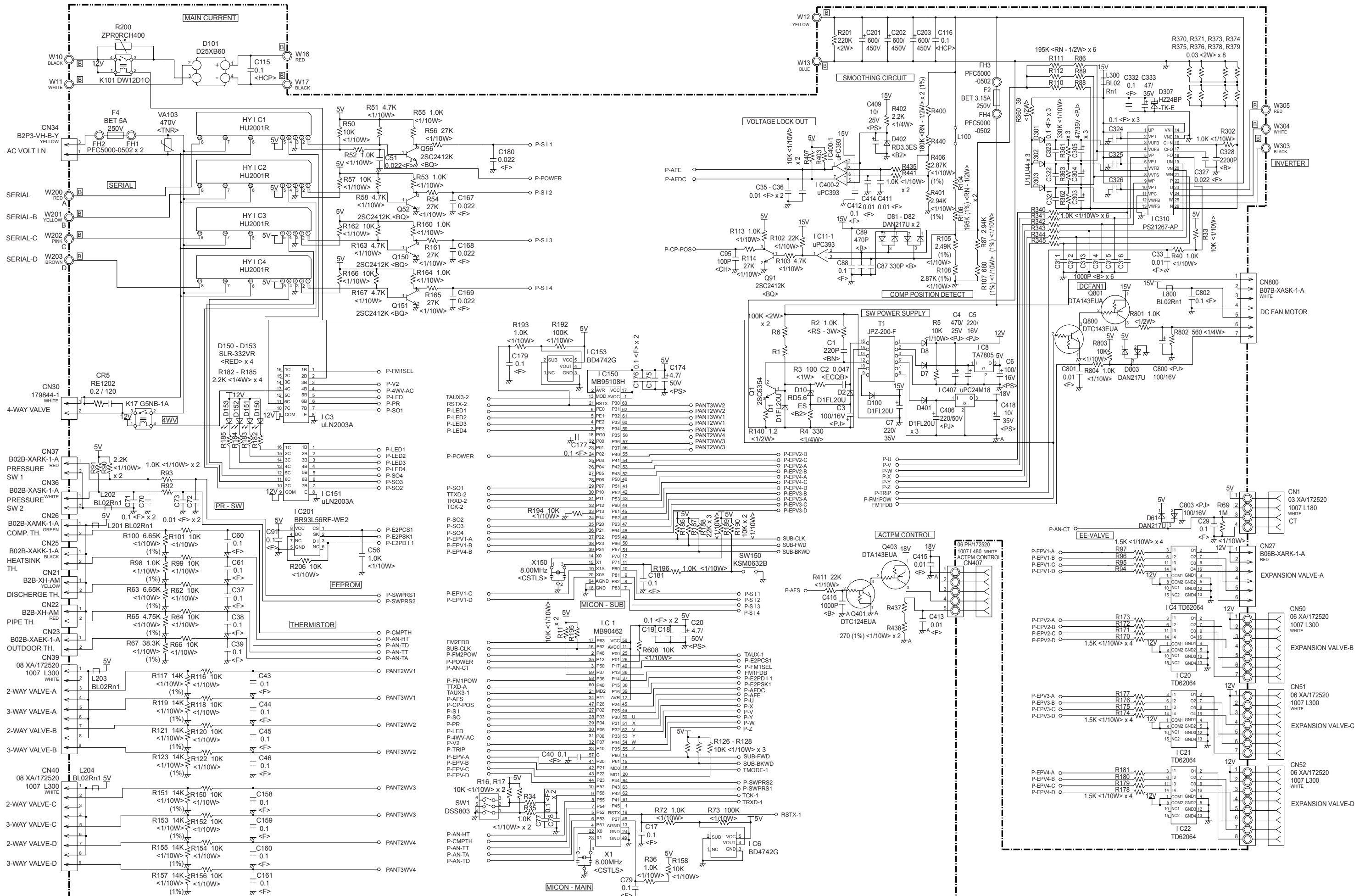

OUTDOOR UNIT
 POWER SUPPLY PCB ASSEMBLY
 K04BA-0402HUE-P0

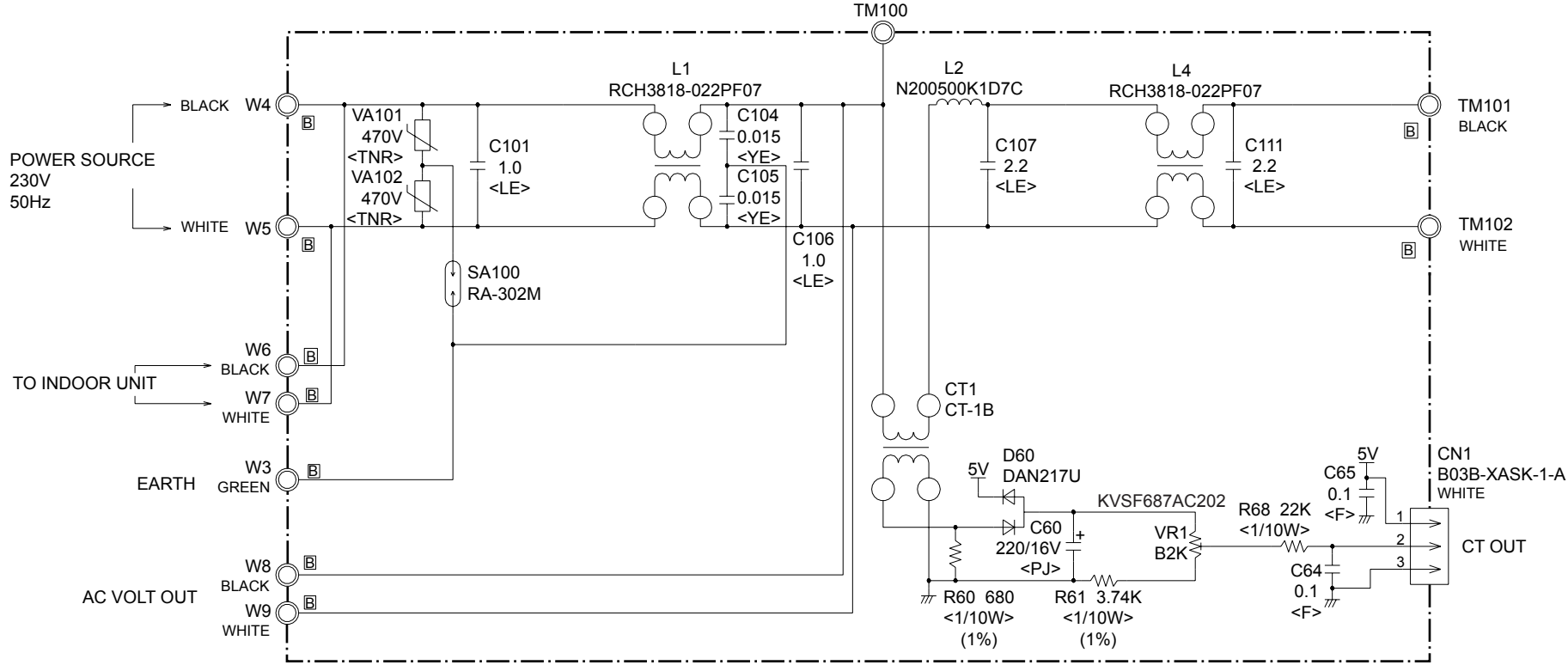

PARTS

INDOOR UNIT

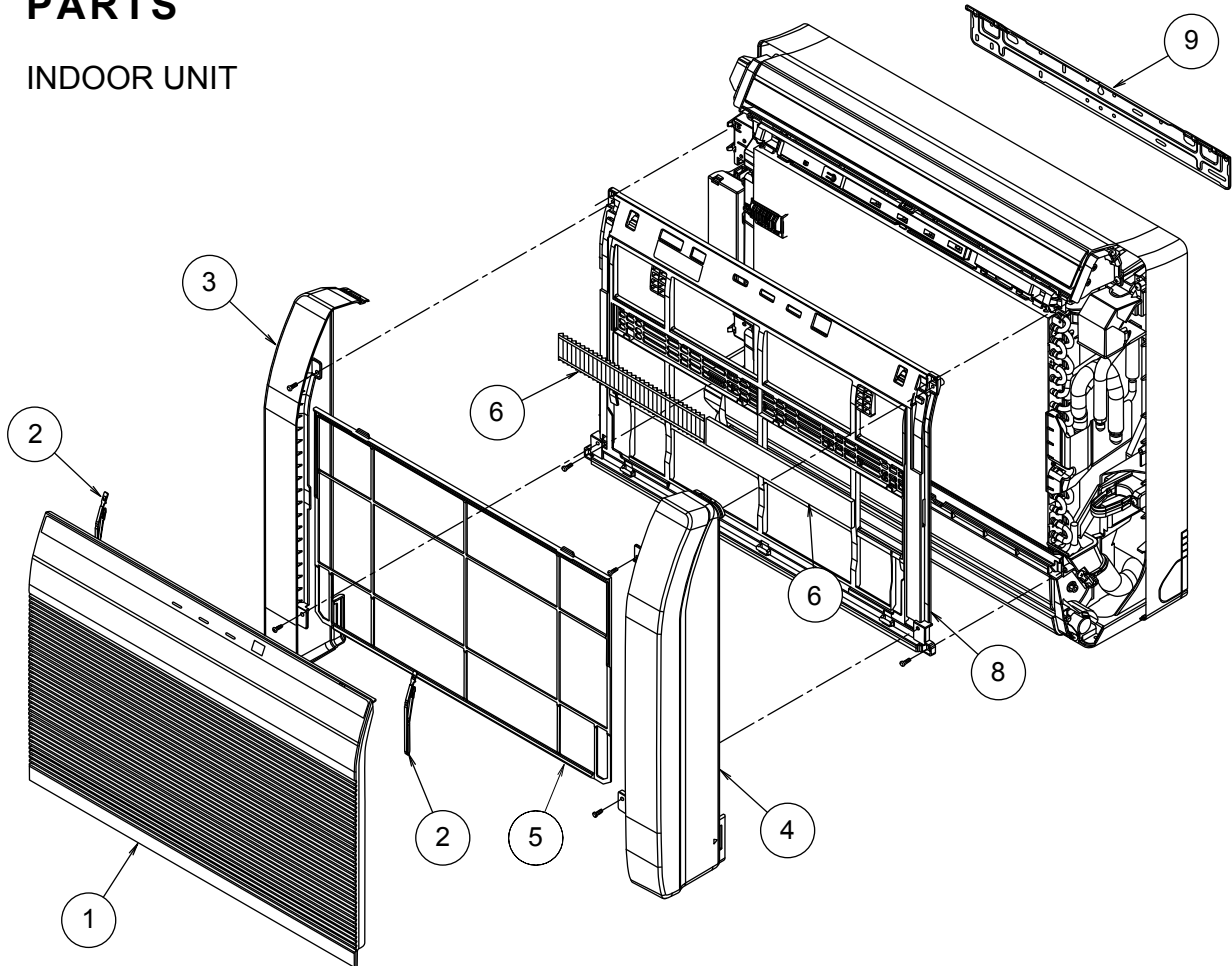

Ref	Description	Parts number
1	Intake Grille Assy	9316418035
2	Rope Assy	9316458017
3	Panel (Front) L	9316187016
4	Panel (Front) R	9316186019
5	Air Filter	9316189010
6	Air Clean Filter Assy	9312152018
8	Panel (Front)	9316185012
9	Bracket Panel	9316272019
--	Remote Control	9316397019
--	Remote Control Holder	9305642045

INDOOR UNIT

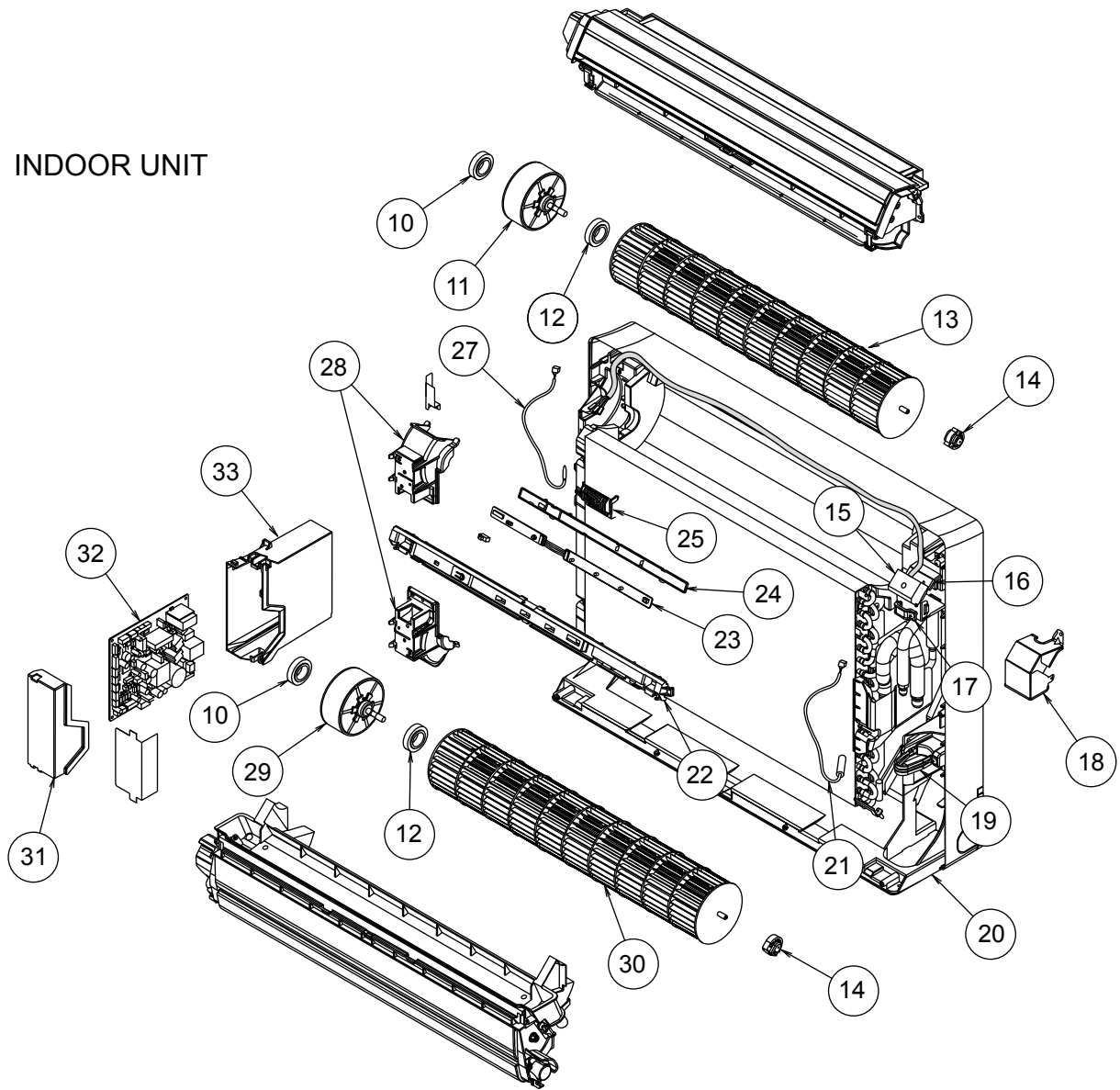

Ref	Description	Parts number	Ref	Description	Parts number
10	Motor Cushion NR	9313168018	23	Display PCB Assy	9707571028
11	Fan Motor, MFD-34ROM	9602109029	24	Display Cover	9316191013
12	Motor Cushion N	9312979011	25	Thermistor Holder	9316192010
13	Crossflow Fan Assy	9312004034	27	Room Thermistor	9700801108
14	Bearing C Assy	9306628017	28	Motor Holder	9316195011
15	Terminal	9900385026	29	Fan Motor, MFD-14SXM	9602481019
16	Bracket (Terminal)	9316269019	30	Crossflow Fan B Assy	9316309012
17	Cord Clamp	9302271002	31	Control Cover	9316201019
18	Cover (Terminal)	9316307018	32	Controller PCB Assy (09)	9707505078
19	Bracket (Pipe)	9316270015	32	Controller PCB Assy (12)	9707505085
20	Base	9316193017	32	Controller PCB Assy (14)	9707505092
21	Pipe Thermistor	9900425012	33	Control Box	9316200012
22	Display Case	9316194014			

INDOOR UNIT

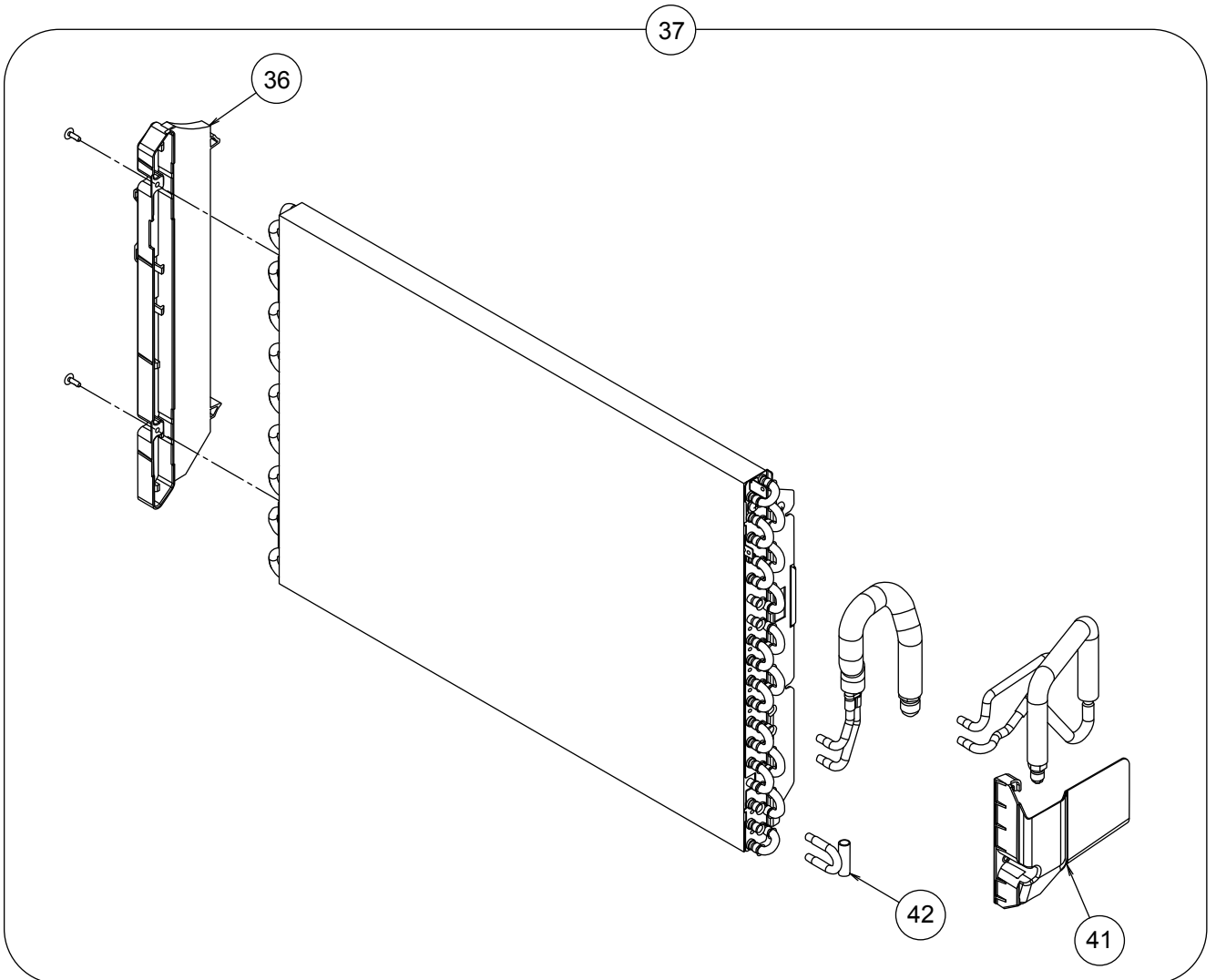

Ref	Description	Parts number	
36	Evaporator Holder	9316199019	
37	Evaporator Total Assy (09, 12)	9316091016	
37	Evaporator Total Assy (14)	9316091023	
41	Water Seal	9316271012	
42	U Pipe AA Assy	9316095014	

INDOOR UNIT

Ref	Description	Parts number
43	Top Cover	9316207011
46	R and L Louver U	9316208018
49	Fan Guard	9316211018
50	Casing	9316204010
51	Bushing B	9312156016
52	Bushing A	9303529010
53	Gear Case	9316213012
54	Gear A	9309994003
55	Motor Step (up / down)	9900384043
56	Louver U	9316205017
57	Louver Z	9316206014
58	REF (Casing)	9316378018

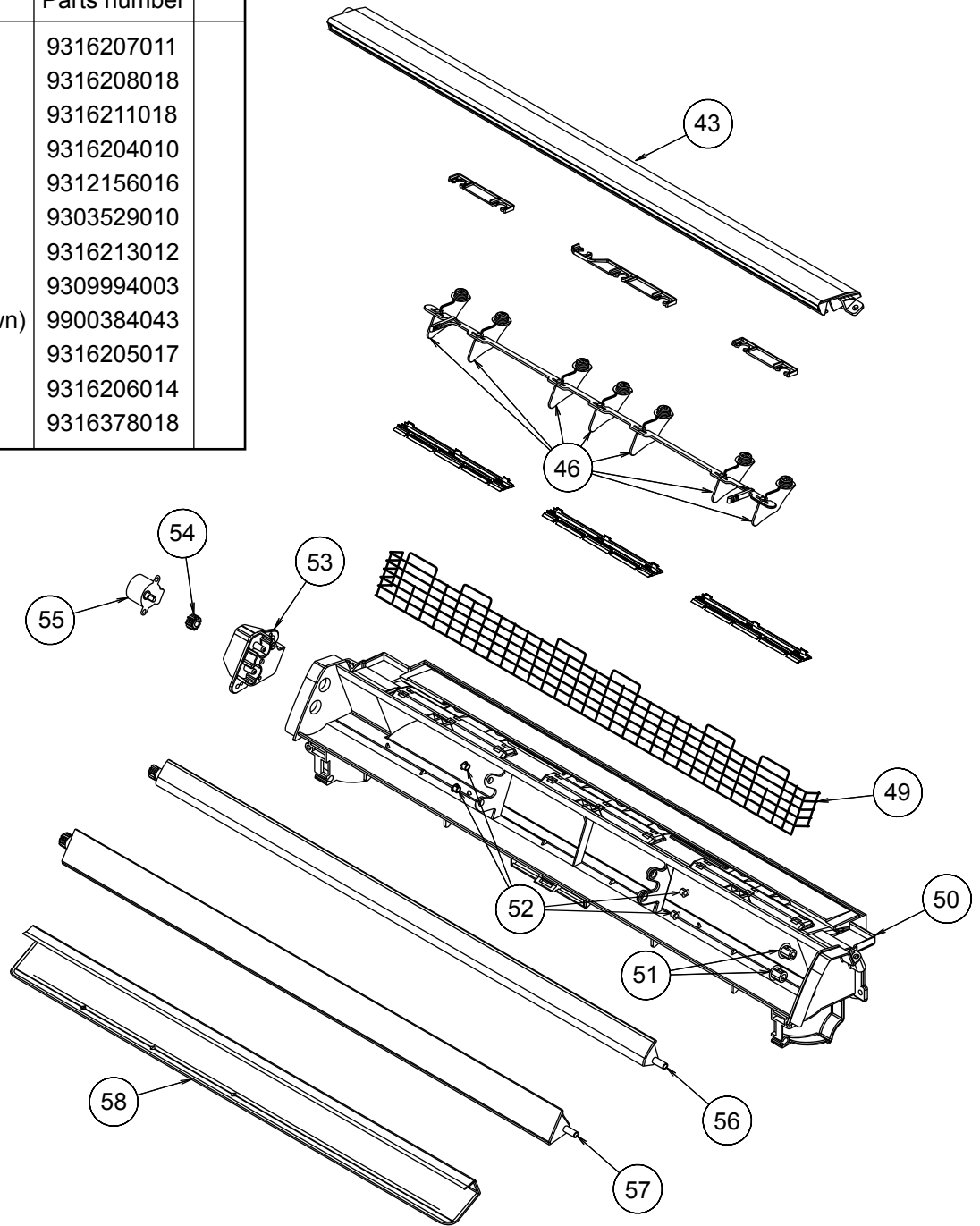

INDOOR UNIT

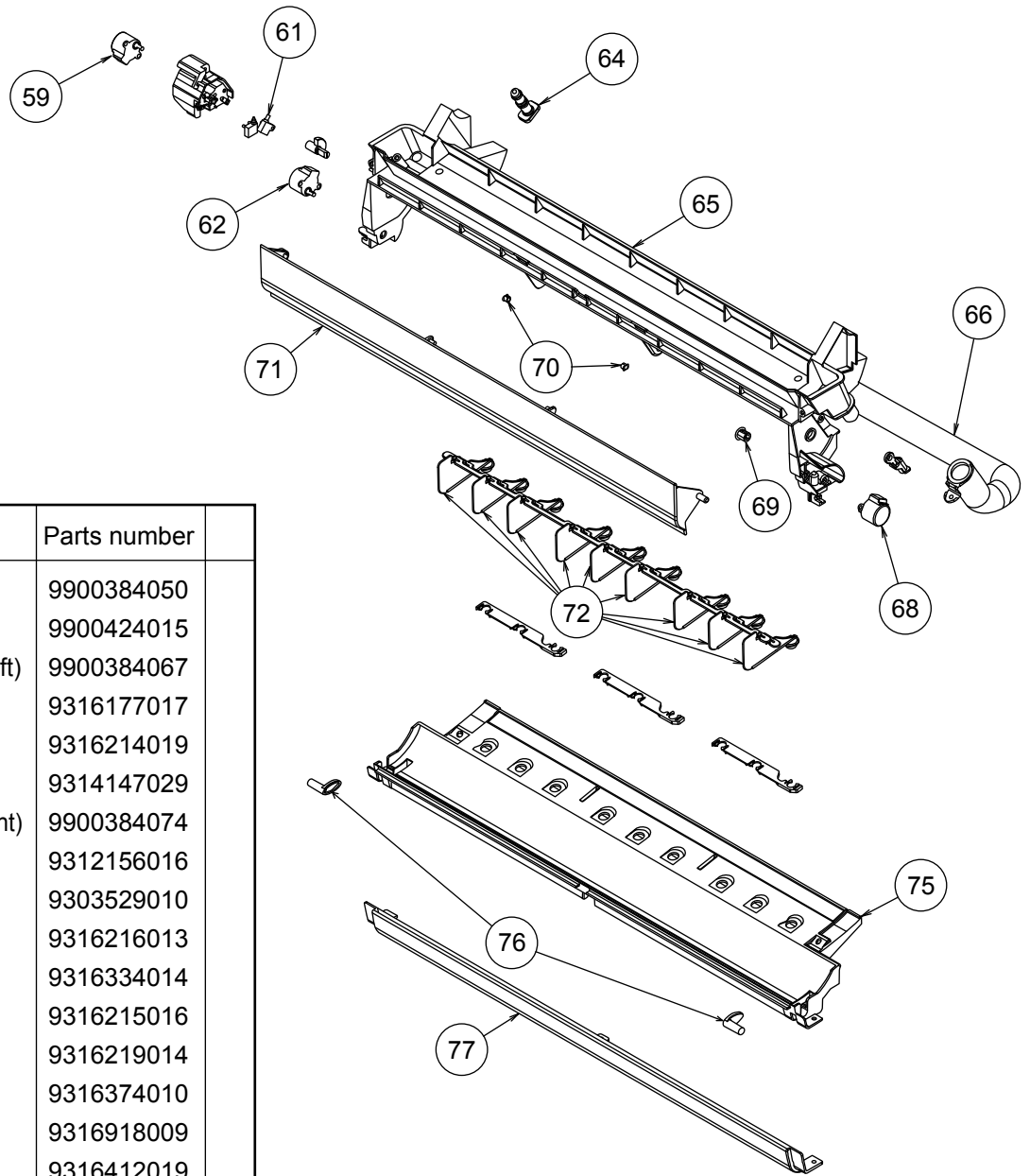

Ref	Description	Parts number
59	Motor Step (Damper)	9900384050
61	Switch Micro	9900424015
62	Motor Step (Damper Lock Left)	9900384067
64	Drain Cap	9316177017
65	Drain Pan U	9316214019
66	Drain Hose Assy	9314147029
68	Motor Step (Damper Lock Right)	9900384074
69	Bushing B	9312156016
70	Bushing A	9303529010
71	Damper	9316216013
72	R and L Louver Z	9316334014
75	Drain Pan Z	9316215016
76	Stopper	9316219014
77	Cover (Lower)	9316374010
--	Fan Guard Z	9316918009
--	Drain Pan Assy	9316412019

OUTDOOR UNIT

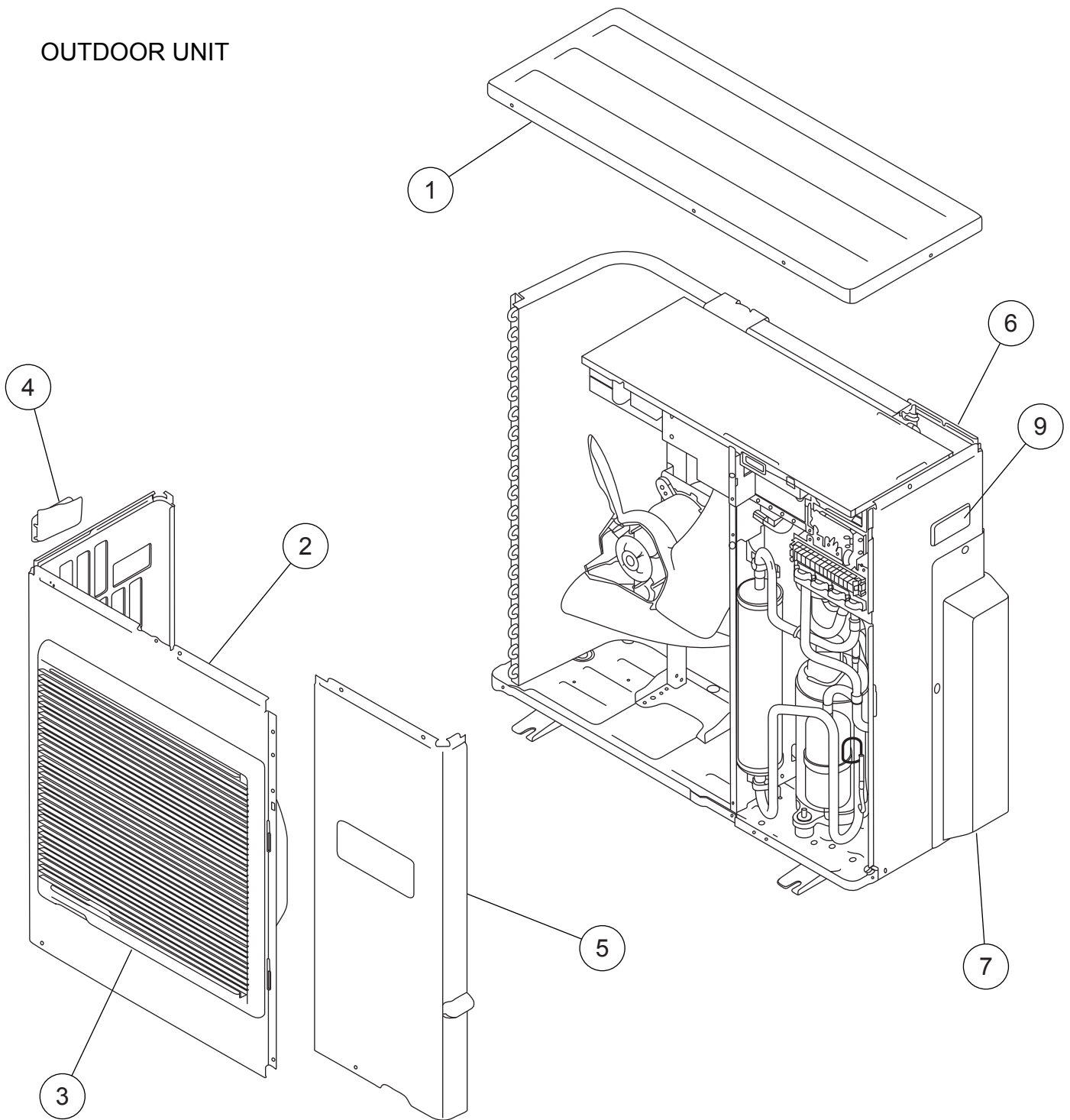

Ref.	Description	Part number
1	Top Panel Sub Assy	9374417025
2	Front Panel	9374094066
3	Fan Guard	9374330010
4	Grip Side	9374173013
5	Service Panel Assy	9374415038
6	Right Panel M	9374599028
7	Valve Cover Sub Assy	9374827015
9	Grip	9374172016

OUTDOOR UNIT

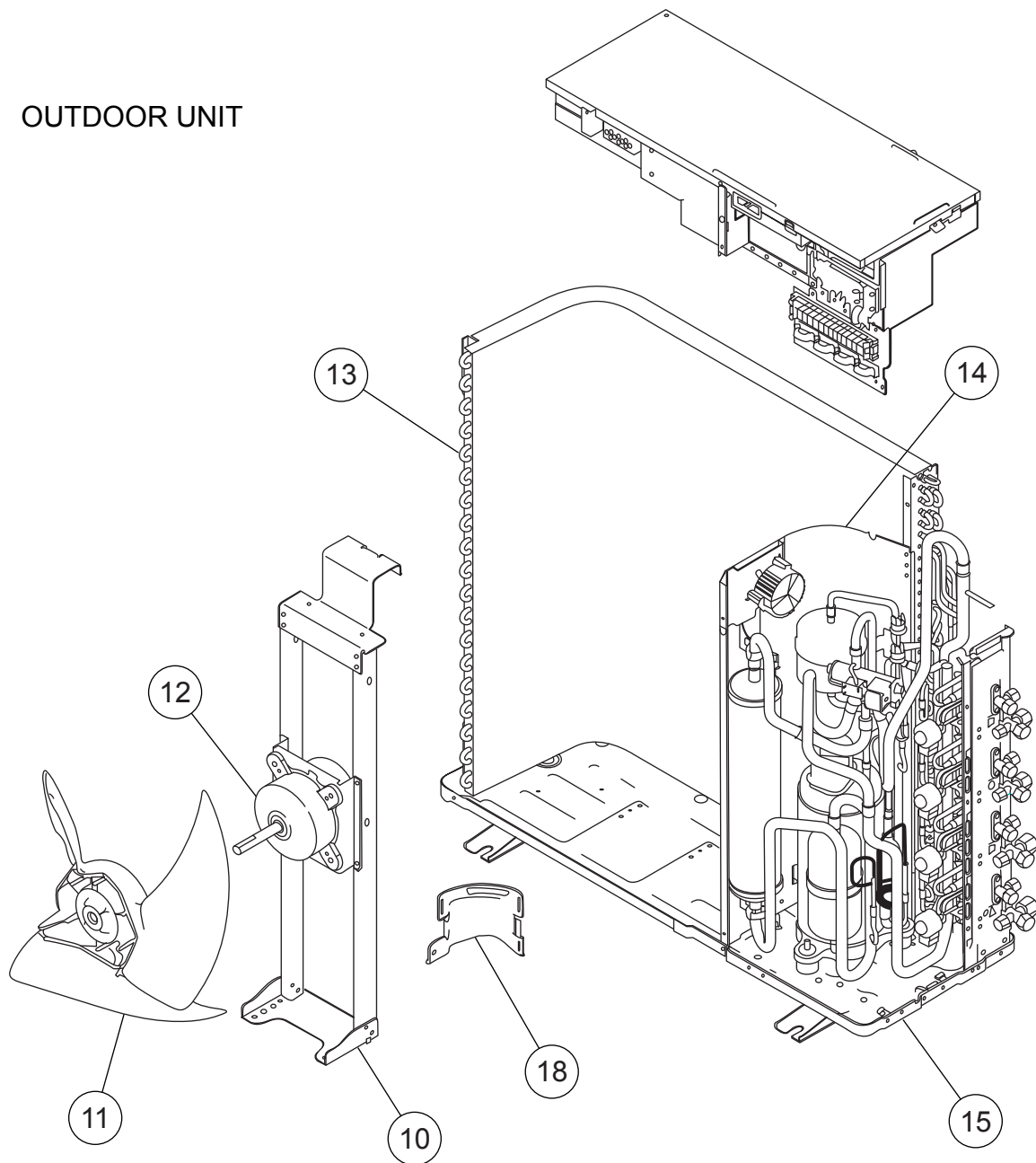

Ref.	Description	Part number
10	Motor Bracket Sub Assy	9374418053
11	Propeller Fan Assy	9366378020
12	Fan Motor	9601882015
13	Condenser A Assy	9374433056
14	Separate Wall Assy	9374629022
15	Base Assy	9374166084
18	Cap Foot	9374345014

OUTDOOR UNIT

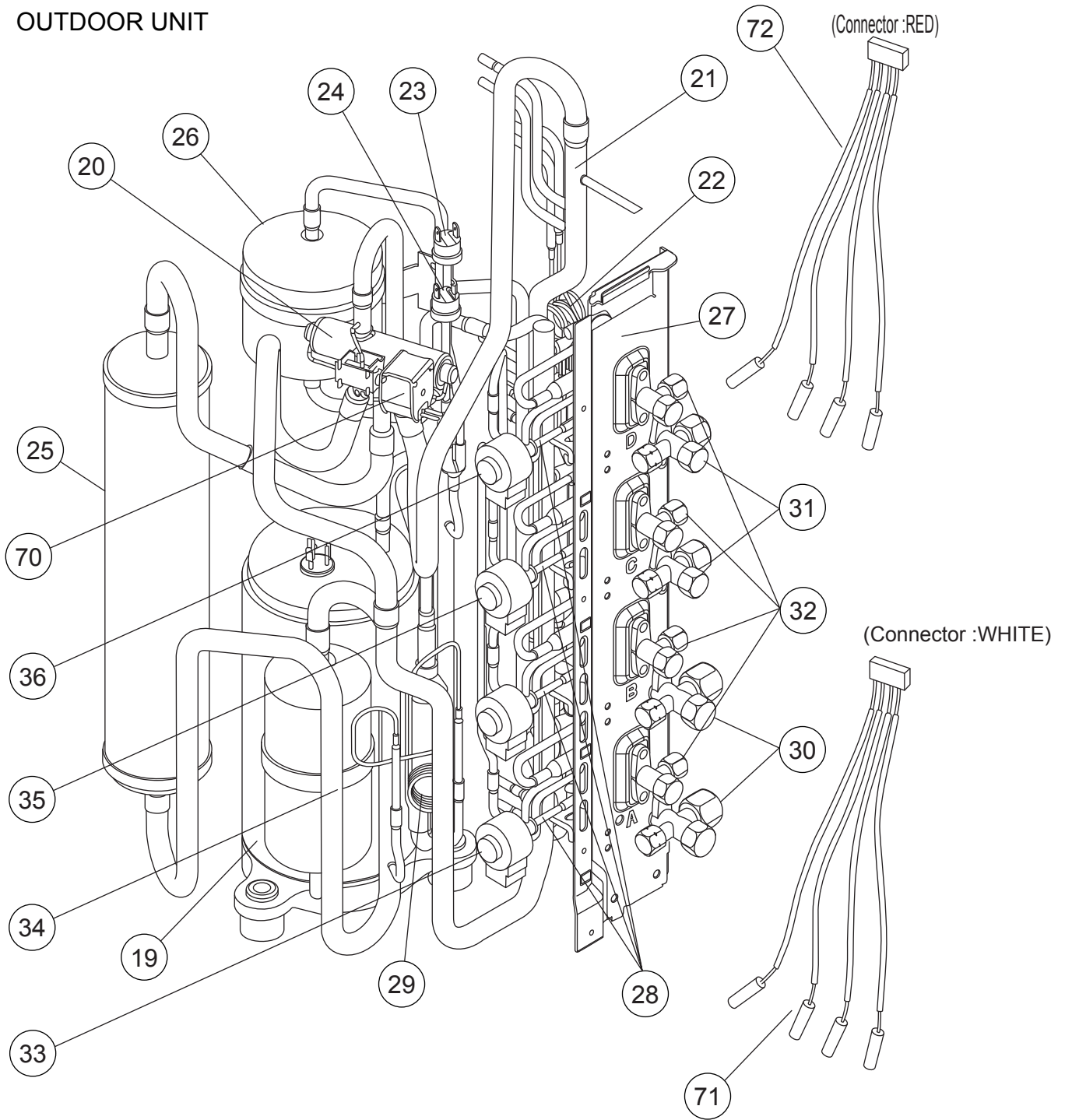

Ref.	Description	Part number	Ref.	Description	Part number
19	Compressor Assy	9377946010	31	3-Way Valve Assy (3/8")	9372205044
20	4-Way Valve Assy	9374425044	32	2-Way Valve Assy	9372204054
21	Inlet Pipe (Cond) A Assy	9373461067	33	Coil (Expansion Valve)(A=Red)	9900057084
22	Outlet Pipe (Cond) A Assy	9374266067	34	Coil (Expansion Valve)(B=White)	9900057053
23	Pressure Switch A Assy	9367726028	35	Coil (Expansion Valve)(C=Green)	9900057060
24	Pressure Switch B Assy	9367727025	36	Coil (Expansion Valve)(D=Blue)	9900057077
25	Accumulator Sub Assy	9374426072	70	Solenoid	9900165055
26	Receiver Tank Sub Assy	9373426028	71	Pipe Thermistor (White)	9900322014
27	Valve Plate A Assy	9374628025	72	Pipe Thermistor (Red)	9900289010
28	Expansion Valve Assy	9370947106	--	Strainer	9372524015
29	Capillary Assy	9372197370	--	Strainer	9366602019
30	3-Way Valve Assy (1/2")	9372205051			

OUTDOOR UNIT
Compressor

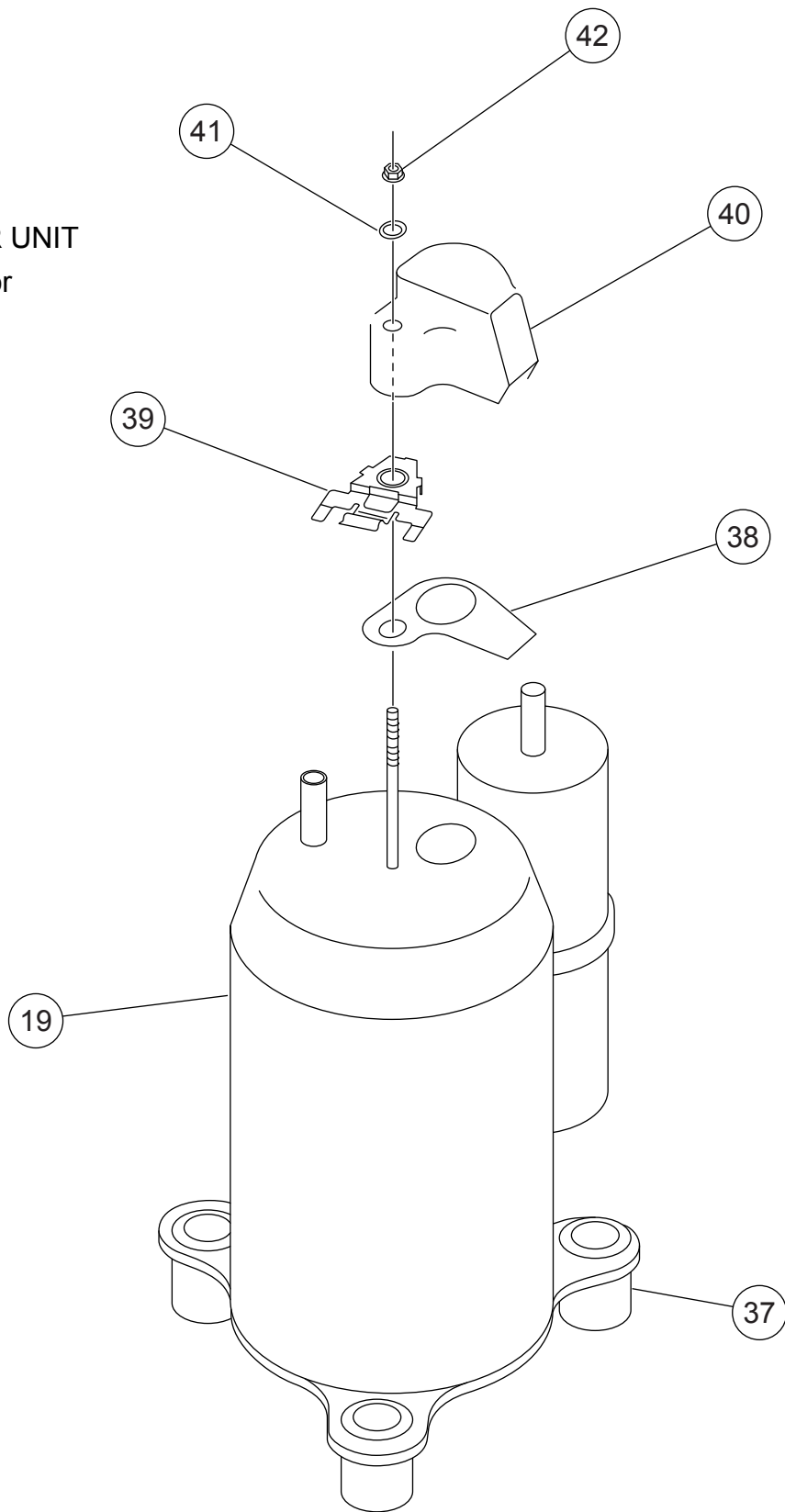

Ref.	Description	Part number
19	Compressor Assy	9377946010
37	Rubber Seat (For Comp)	9377951014
38	Terminal Packing	9377948014
39	Holder	9377952011
40	Terminal Cover (Comp)	9377947017
41	Washer (Rubber)	9377949011
42	Frange Nut	9377950017

OUTDOOR UNIT

Inverter assy



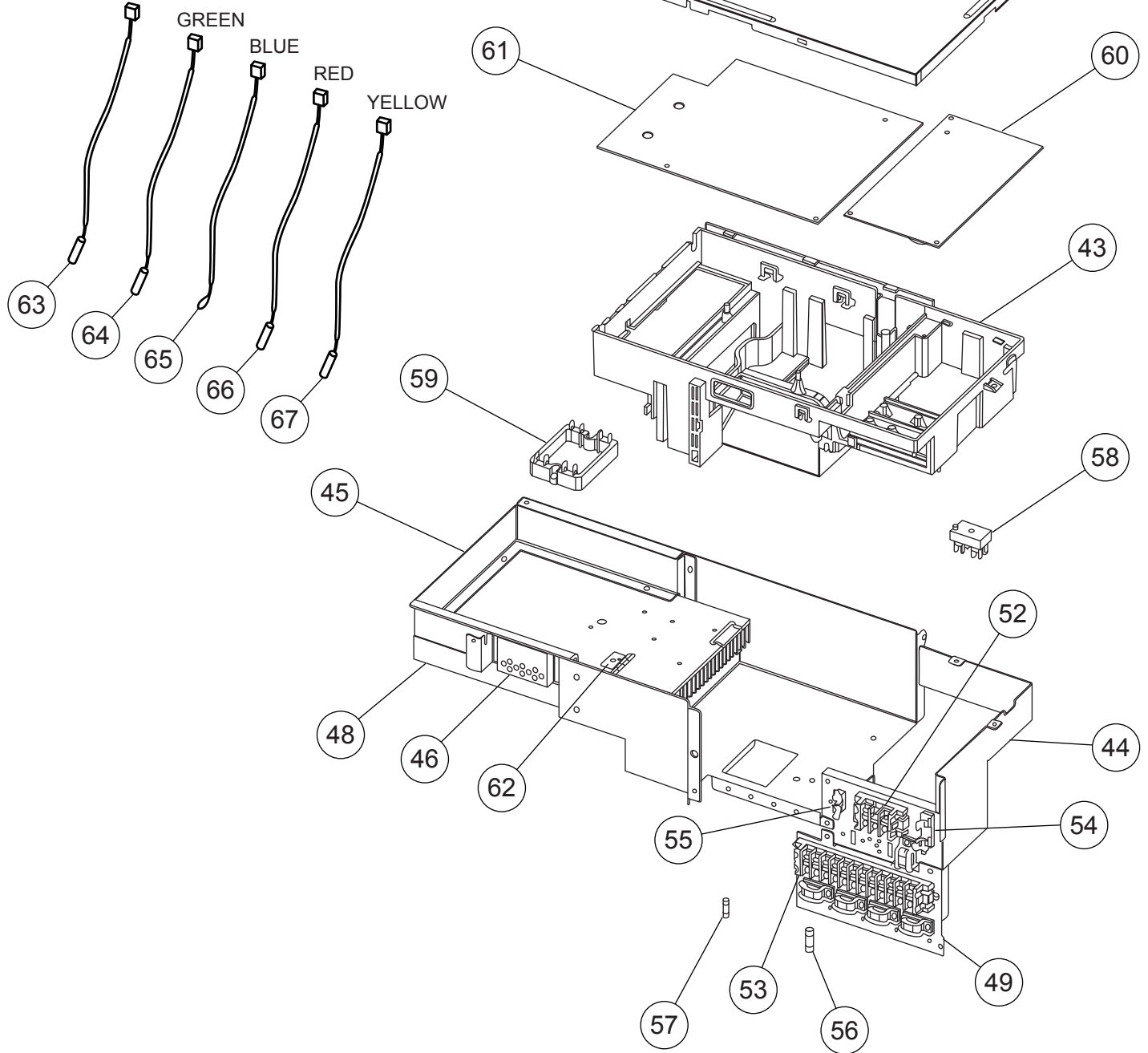



Connector : BLACK



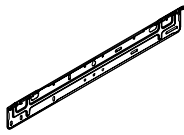

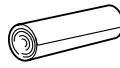
Ref.	Description	Part number	Ref.	Description	Part number
43	Inverter Box A	9374603015	57	Fuse (Small)	0600376116
44	Inverter Box B Assy	9374625017	58	Terminal	9701971015
45	Inverter Box C	9374605019	59	ACTPM	9703457012
46	Inverter Box Duct	9374609017	60	Power Supply PCB Assy	9705647039
47	Inverter Box Cover	9374608010	61	Controller PCB Assy	9705642058
48	Heat Sink A	9374607013	62	Holder (Thermo)	9372797013
49	Inverter Box D	9374606016	63	Heat Sink Thermistor	9900311018
52	Terminal (3P)	9900203016	64	Compressor Thermistor	9900156022
53	Terminal (12P)	9358660164	65	Thermistor (Outdoor)	9703516078
54	Fuse Holder (Big)	0501454012	66	Heat Exchanger Thermistor	9704220059
55	Fuse Holder (Small)	0501456016	67	Discharge Pipe Thermistor	9704219114
56	Fuse (Big)	0600086039			

STANDARD ACCESSORIES

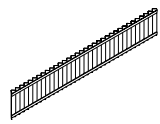
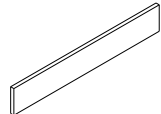
INDOOR UNIT

Name and Shape	Q'ty	Use	Part number
Bracket panel 	1	For indoor unit installation	9316272019
Remote control AR-RAC1E 	1	Use for air conditioner operation	9316397019
Battery (penlight) 	2	For remote control	0600185527
Cloth tape 	1	For indoor unit installation	9310519004
Remote control holder 	1	Hold a remote control	9305642045
Tpping screw (big) ($\phi 4 \times 25$) 	9	For wall hook bracket and body installation	0700076046
Tpping screw (small) ($\phi 3 \times 12$) 	2	Install remote control holder	0700019036
Electric filter UTR-FC03-2 	1	With 2 sheets	9312832002
Ion deodrant filter UTR-FC03-3 	1	With 2 sheets	9312833009

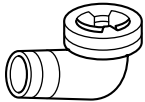
OUTDOOR UNIT

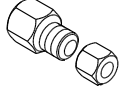
Name and Shape	Q'ty	Use	Part number
Drain pipe 	1	For outdoor unit drain piping work	9303029015
Drain cap 	1		313166024302
Adapter assy 12.7 mm → 9.52 mm (1/2 in.) (3/8 in.) 	1	For use when connecting models 9-12 to outdoor port A	9370244007

0801G3370